



ELORA TOOL CATALOGUE

The background of the page is a complex network of white and yellow lines connecting various nodes, overlaid on a blurred image of a hand holding a smartphone. The network is denser in the upper left and lower left corners, and sparser in the upper right and lower right corners. The overall color palette is dominated by yellow, white, and dark blue/grey.

ELORA – ALL AROUND THE GLOBE

All round the globe, customers put their faith in ELORA, a key trade name from Germany. They appreciate the high quality standard of our products and our exemplary after-sales services.

You are sure to find one of our many approved dealers close to your location.

You won't be disappointed.



ASSORTMENTS
AND STORAGE UNITS

FROM PAGE 12



SPANNERS AND WRENCHES

FROM PAGE 68

DEAR CUSTOMERS AND BUSINESS PARTNERS,

ELORA Werkzeugfabrik GmbH's success story began in 1924.

Today, the company is renowned for its user-friendly products and first-class services for all things to do with hand tools. The current range of products is the result of decades of experience and never-ceasing efforts to develop new products and improve existing ones to the benefit of our customers and their many applications. Functionality, durability and appealing designs are at the focus of our efforts. Our customers worldwide show their appreciation of our approach by remaining loyal, satisfied customers for many years. As a customer and friend of ELORA tools you can look forward to the highest level of commitment and the skilled involvement of all the ELORA employees.

This is our personal promise to you that you can gauge us by.

We look forward to responding to your specific needs.

Your
Andreas Rauch
Managing Partner



03

SOCKETS AND ACCESSORIES
FROM PAGE 122



04

IMPACT TOOLS

FROM PAGE 196

ELORA TOOLS ARE PREMIUM QUALITY TOOLS – THE PREFERRED CHOICE FOR CUSTOMERS AND USERS.

Hand tools made by ELORA are established worldwide. ELORA tools offer both skilled craftsmen and astute businessmen virtually everything they expect of high-quality products in this field.

Customers in many sectors of industry are supplied exclusively through authorised dealers. Those sectors include workshops, production facilities, heavy industry, the automotive industry and commercial power generation.

Understandably, professionals in these industries are mainly interested in premium quality.

At ELORA, we guarantee that quality, which is why, right from the development stage on, we place considerable emphasis on maximum functionality, ergonomics, durability and contemporary design.

In the production process, we exclusively use tried-and-tested, high-grade materials. In line with our traditions, all the tools are manufactured to the highest quality standards. The company is certified to DIN EN ISO 9001:2015. In addition, our products and services comply worldwide with recognised industrial and quality standards, such as VDE and ESD.

Finally, before our tools leave the factory, they are all subjected to strict quality inspection. Every single one. Should there ever be cause for one of the rare complaints, you can rest assured that ELORA's full warranty will take effect. After inspection by our staff, the tool will be either repaired or replaced — usually within a very short time.

Our dedicated, qualified contacts are also at your disposal for any other queries or comments you may have about our quality tools. ELORA's customer service team is ready to advise you on solving particular challenges.

Our sales staff consider after-sales customer services to be just that — services to benefit customers.

You are welcome to try us, whether you have a question concerning maintenance, repair or sourcing spare parts.

05

TORQUE WRENCHES

FROM PAGE 234

06

SCREWDRIVERS

FROM PAGE 250

EFF

ELORA-FAMILY-FACTS

In addition to our range of products, we are delighted to introduce some of our ELORA employees as part of this catalogue.

Without them, their exemplary commitment and their know-how, ELORA would not be what it is today.

The combination of professional advice, our uncomplicated order processing system and the state-of-the-art centralised warehouse enable us to process your orders quickly and efficiently and guarantee excellent availability, so you get the tools you order on-site as fast as possible. And this is backed by our attractive terms & conditions.

This does not mean, though, that we feel content to rest on our laurels. We are constantly working on improving our performance in all aspects of what we do. Our customers are an important part of this process as they contribute their ideas and expectations frankly and honestly. And those expectations are the yardstick by which we would like to be measured in the future.





ELECTRICIAN AND FINE MECHANICS TOOLS

FROM PAGE 280



PLIERS

FROM PAGE 324

FUTURE HAS ORIGINS. THE ELORA SUCCESS STORY AT A GLANCE.

1928

First company building on Birker Weg, Remscheid



1937

Always close to the customer: the ELORA delivery van..

1951

ELORA active as an exhibitor both home and abroad



1968

Expansion of the production facility on Schmiedestraße

1924

Business established by Erich Rauch Sen.

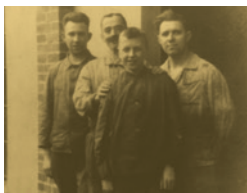

1931

The first ELORA employees.

1949

One of the first trucks after the war years.

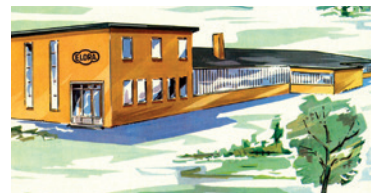

1958

New construction of the subsidiary plant in Münk/Eifel



STRIKING TOOLS

FROM PAGE 366



PNEUMATIC TOOLS

FROM PAGE 392

1986

Management in the second generation



1998

Family business in the third generation



2018

LEO supports the team.



2014

Anniversary: 90 years of ELORA



1994

Moving to the administration building, Am Blaffertsberg



2012

Signs of change: contemporary trade fair image



2016

The ELORA showroom ELORADO

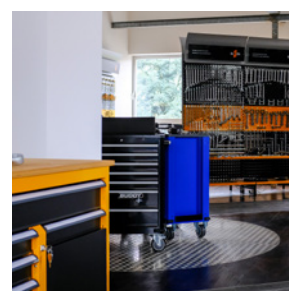



MEASURING AND CHECKING TOOLS

FROM PAGE 404



AUTOMOTIVE AND SPECIAL TOOLS

FROM PAGE 424

SIGN DECLARATION

size in mm

size in AF

size in BA

size in Whitworth (WW)

size in mm

size in AF

TORX® size corner to corner in mm

size for slotted round nuts for hook spanners in mm

size for capstan screws in mm

size for round nuts with drilled holes in mm

drive

drive

drive

drive

drive

drive

drive

drive

hexagon pattern

bi-hexagon pattern

male square

female square

thread diameter of spark plugs

suitable for plain slotted screws

suitable for cross slotted and Phillips Recess screws

suitable for cross slotted and Supa-Pozidriv screws

suitable for male hexagon screws

suitable for safety made hexagon (tools with hole in tip)

suitable for outside-TORX®-screws

suitable for inside-TORX®-screws

suitable for outside-TORX®-safty-screws (tools with hole in tip)

suitable for B&S-XZN-screws

suitable for RIBE®-CV-screws



DIFFERENT TOOLS

FROM PAGE 472



sizes of threads in mm



edges, wire strippers



with bevel



without bevel



fine bevel



edges, e.g. flat pliers etc.



edges, half round pliers



edges, round pliers



soft wire,
tensile strength 220-250 N/mm²



medium hard wire,
tensile strength 750-800 N/mm²



piano wire,
tensile strength 2200-2300 N/mm²



for internal retaining rings



for external retaining rings



weight of hammer heads



length



weight of each piece or set



ring sides of spanners with wave profile



stainless steel



magnetic



VDE tested, voltage with stand strenght
up to 1000V



approved safety



ELORA'S RANGE OF PRODUCTS IS CHARACTERISED BY VARIETY.

In total, we have 13 product families to provide customers with numerous opportunities for compiling their own sets of hand tools for their daily work.

Further details on the sub-families of tools can be found on the introductory pages at the beginning of each ELORA product family.

Whether you opt for a set from our range of carefully compiled tool assortments or a single ELORA-Tool, you can rely on the fact that you will be buying tried-and-tested peak quality.

CHAPTER			—	PAGE	
01	Assortments and storage units		—	12	01
02	Spanners and wrenches		—	68	02
03	Sockets and accessories		—	122	03
04	Impact tools		—	196	04
05	Torque wrenches		—	234	05
06	Screwdrivers		—	250	06
07	Electrician and fine mechanics tools		—	280	07
08	Pliers		—	324	08
09	Striking tools		—	366	09
10	Pneumatic tools		—	392	10
11	Measuring and checking tools		—	404	11
12	Automotive and special tools		—	424	12
13	Different tools		—	472	13



ASSORTMENTS AND STORAGE UNITS

Roller Tool Cabinets, Tool Boxes, _____ Page 14
Accessories

Tool Modules _____ Page 25

Tool Assortments _____ Page 52



We put people first at ELORA.
The satisfaction of our customers and the well-being of our employees are our highest asset.

1220-L...

ROLLER TOOL CABINET SUPER CADDY

01

- 1220-L7 with 7 drawers, 1220-L8 with 8 drawers
- solid metal sheet pattern, ELORA-yellow (RAL 1006)
- corrosion- and scratch-resistant powder-coating
- shelf space on the top made of ABS plastic with 7 storage compartments for small parts and rim on all sides
- 200 kg shelf load capacity due to strengthened top cover
- solid handlebar, mounting possible on both sides
- sides and back panel with Euro-Perforation 10 x 38 mm (hole square 10 x 10 mm, hole centre-hole centre 38 x38 mm) for mounting accessory hooks, trays, waste basket, can holder, paper roll holder, cable drum
- central locking system with cylinder lock and 2 keys
- loading capacity of each drawer 40 kg
- each drawer has a safety locking system and is 100% extractable
- drawer with ball bearing guide rails
- drawer internal measurements W 573 x D 410 mm
- drawers ELORA-black powder-coated (RAL 9005)
- can be individually divided with separators or equipped with ELORA-OMS modules
- total loading capacity 300 kg
- broad gauge running gear with 4 Ø 125 mm full rubber, smooth running castors, 2 swivel castors with double break function (tangential and axial)
- dividers for drawers separately available
- delivery without tools and accessories
- suitable assortments: WS and OMS
- **other drawer types and special colours on request**

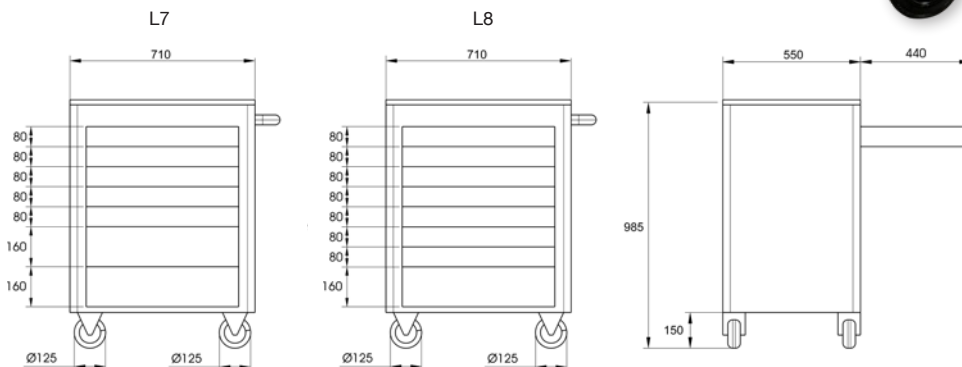

Code	Number	Height mm	Width mm	Depth mm	Loading Capacity kg	Pieces	Weight/g
1220000006000	1220-L7	977	705	545	300	1	78000
1220000006008	1220-L8	977	705	545	300	1	78000

1225-L7

ROLLER TOOL CABINET TOOLJET

01

- 7 drawers
- solid metal sheet pattern with solid sub construction, ELORA-yellow (RAL 1006)
- corrosion- and scratch-resistant powder-coating
- shelf space on the top made of ABS plastic with 7 storage compartments for small parts and rim on all sides
- 200 kg shelf load capacity due to strengthened top cover
- solid ergonomic steel reinforced handlebar, mounting possible on both sides
- sides and recessed back panel with Euro-Perforation 10 x 38 mm (hole square 10 x 10 mm, hole centre-hole centre 38 x 38 mm) for mounting accessory hooks, trays, waste basket, can holder, paper roll holder, cable drum
- central locking system with cylinder lock and individual drawer lock system (if one drawer is open it is not possible to open another one)
- loading capacity of each drawer 40 kg
- each drawer has a safety locking system and is 100% extractable
- drawer with ball bearing guide rails
- drawer internal measurements W 573 x D 410 mm
- drawers ELORA-black powder-coated (RAL 9005)
- can be individually divided with separators or equipped with ELORA-OMS modules
- total loading capacity 450 kg
- broad gauge running gear with 4 Ø 125 mm full rubber, smooth running castors, 2 swivel castors with double break function (tangential and axial)
- delivery without tools and accessories
- suitable assortments: WS and OMS
- dividers for drawers separately available
- **other drawer types and special colours on request**

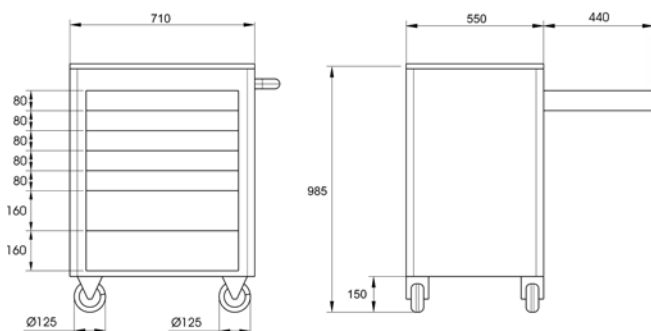

Code	Number	Height mm	Width mm	Depth mm	Loading Capacity kg	Pieces	Weight/g
1225000006000	1225-L7	980	705	545	450	1	82000

1110-..., 1220-...

ACCESSORIES ROLLER TOOL CABINET SUPER CADDY AND TOOLJET

- for use at back and side panels of roller the tool cabinets ELORA-No. 1220-L7, 1220-L8 and 1225-L7
- at the side and rear panel of the roller tool cabinet accessories can be mounted by using the Euro-perforation 10 x 38 mm (square 10 x 10 mm, hole centre to hole centre 38 x 38 mm)
- holder made of steel sheet, 1,25 mm thick
- 1110 KH made from plastic



1220-KS

1220-PH

1220-PK

1220-DH

1220-KT

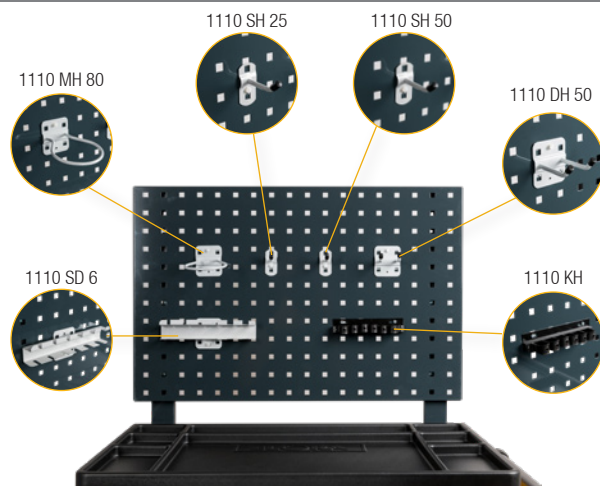

Code	Number	Productinformation	Dimensions WxHxD	Pieces	Weight/g
1110900002025	1110 SH 25	Tool Holder	-	1	20
1110900002050	1110 SH 50	Tool Holder	-	1	24
1110900012050	1110 DH 50	Tool Holder, double hook	-	1	62
1110900002080	1110 MH 80	Machine Holder	-	1	84
1110900002006	1110 SD 6	Screwdriver Holder	-	1	169
1110900002000	1110 KH	Terminal Holder, plastic	-	1	16
1220800016000	1220-PK	Waste Basket	300x300x250	1	2860
1220800026000	1220-PH	Paper Roll Holder	300x200x150	1	1430
1220800036000	1220-DH	Can Holder	300x200x150	1	2110
1220802206000	1220-AS220	Tray	220x60x80	1	540
1220803006000	1220-AS300	Tray	300x60x80	1	720
1220800046000	1220-KT	Cable Roller 10 m	-	1	2000
1220800056000	1220-RW	Rear Panel	455x700	1	6800
1220800066000	1220-KS	Edge protector	-	1	350

1220-TBS..., 1220-FTS...

SEPARATING PLATES

- drawer division for ELORA-Super Caddy ELORA-No. 1220-L7, 1220-L8 and ELORA ToolJet, ELORA-No. 1225-L7 for division of the drawers
- zinc-plated metal sheet

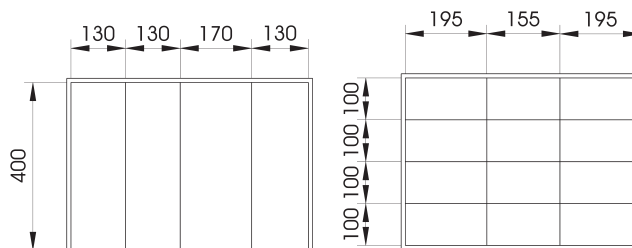

Code	Number	Productinformation	Height mm	Pieces	Weight/g
1220800606000	1220-TBS60	Separating Plate, 3 pcs.	60	1	200
1220801006000	1220-TBS100	Separating Plate, 3 pcs.	100	1	350
1220800806000	1220-FTS80	Separator Set	80	1	1120
1220801606000	1220-FTS160	Separator Set	160	1	3035

1200-RM 18

ANTI SLIP MAT

- for drawers in tool cabinets and work benches
- Length: 2m



Code	Number	Width mm	Pieces	Weight/g
1200004752000	1200-RM 18	475	1	650

1210-L...

ROLLER TOOL CABINET BUDDY

- 7 drawers
- solid metal sheet pattern, corrosion- and scratch-resistant powder-coating
- shelf space on the top made of ABS plastic with 5 storage compartments for small parts and rim on all sides
- solid handlebar, mounting possible on both sides
- up to 6 different accessories mountable in the recessed side wall e.g. storage foldable tray for small parts ELORA No. 1210-ES, screwdriver tray for 8 screwdrivers ELORA No. 1210-SD
- 2 can holder are included
- central locking system with 2 keys
- loading capacity of each drawer 20 kg respectively 30 kg for the two lower drawers
- each drawer has a safety locking system and is 100% extractable
- drawer with ball bearing guide rails
- drawer internal measurements W 570 x D 410 mm
- drawers ELORA-black powder-coated
- can be Individually equipped with ELORA OMS modules
- total loading capacity 300 kg
- broad gauge running gear with 4 Ø 125 mm full rubber, smooth running casters, 2 swivel castors with double break function (tangential and axial)
- delivery without tools and accessories
- suitable assortments: WS and OMS



1210-L7B

1210-L7R

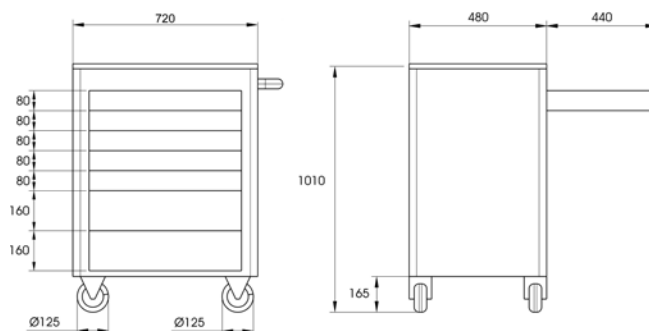

Code	Number	Height mm	Width mm	Depth mm	Loading Capacity kg	Pieces	Weight/g
1210000006000	1210-L7	1010	710	470	300	1	67000
1210000016000	1210-L7R	1010	710	470	300	1	67000
1210000026000	1210-L7B	1010	710	470	300	1	67000

1210-...

ACCESSORIES ROLLER TOOL CABINET BUDDY

- ▶ for ELORA roller tool cabinet Buddy; ELORA-No. 1210-L...
- ▶ up to 6 different accessories mountable in the recessed side wall e.g. storage foldable tray for small parts ELORA No. 1210-ES, screwdriver tray for 8 screwdrivers ELORA No. 1210-SD
- ▶ the wooden panel ELORA No. 1210-PL fits exactly onto the ABS-storage shelf and make it a plane working surface



Code	Number	Productinformation	Pieces	Weight/g
1210800001001	1210-ES	Foldable Tray	1	550
1210800001002	1210-SD	Screwdriver Tray	1	410
1210800001003	1210-PL	Wooden Panel	1	4000

1210-ET...

DRAWER SEPERATOR FOR ROLLER TOOL CABINET BUDDY

- ▶ for division of the drawers
- ▶ metal sheet

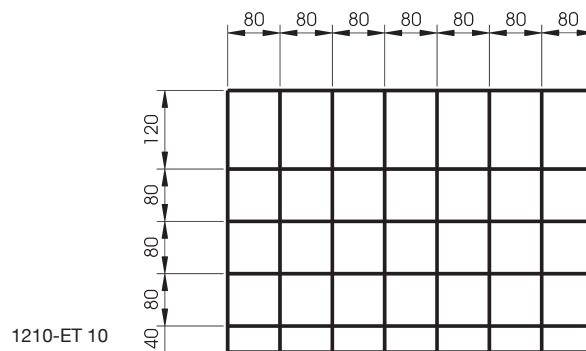
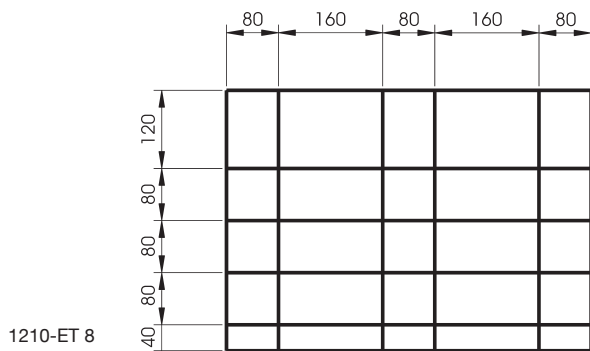
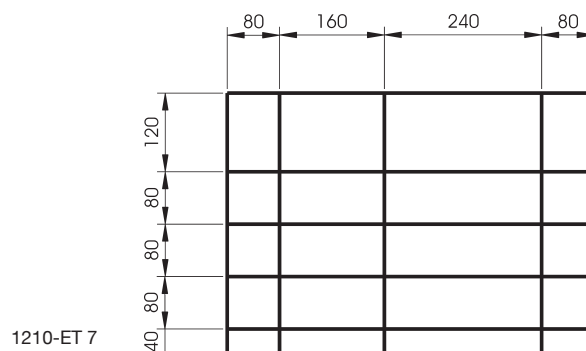
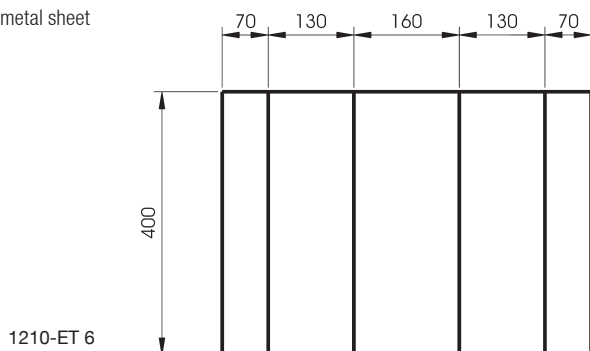

Code	Number	Productinformation	Height mm	Pieces	Weight/g
1210800061000	1210-ET 6	6 pcs.	50	1	1108
1210800071000	1210-ET 7	7 pcs.	50	1	1086
1210800081000	1210-ET 8	8 pcs.	50	1	1212
1210800101000	1210-ET 10	10 pcs.	50	1	1566

1811-L

WHEELED WORK BENCH

- scratch resistant, powder coated, ELORA-yellow (RAL 1006), door/drawers black (RAL 9006)
- laminated beech wood (Multiplex) work bench board
- drawers with ball-bearing guide rails, full telescopic drawer slide
- 6 drawers with roller bearing, internal dimensions of drawers: width 573 x Depth 410
- individual separation using length- and cross dividers, resp. using ELORA OMS-modules
- central locking with mutual drawer locking
- 40kg load capacity per drawer
- separate door locking, with one shelf (storage space with separately lockable door and one shelf)
- front side panels with square Euro holes
- stable handle
- 2 fixed and 2 braked swivel castors
- total load capacity 450 kg
- suitable assortments: all OMS-Modules

01

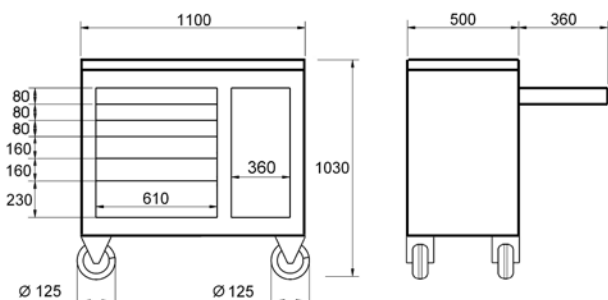

Code	Number	Width mm	Height mm	Depth mm	Pieces	Weight/g
1811500006000	1811-L	1200	1025	505	1	93000

1810-L

WORKBENCH

- massive beech wood bench top, bolt like laminated, oiled, 40 mm
- static load: 300 kg (distributed load)
- floor level adjustment screws
- drawers 100% extractable
- drawers internal measurements W 433 x D 538 mm
- load each drawer: ca. 35 kg
- central locking system for the drawers
- 2 locks per workbench keyed alike, main key available
- drawers can be divided with separator set ELORA-No. 1810-ET
- storage space with shelf and door
- door lockable by 2 cylinder locks, simultaneous locking
- powder-coated, body ELORA-yellow (RAL1006, door/drawers ELORA-black RAL9005)



Code	Number	Height mm	Width mm	Depth mm	Loading Capacity kg	Pieces	Weight/g
1810500006000	1810-L	840	1200	600	300	1	93000
1810500007000	1810-ET	60	-	-	-	1	800

1227-L
CABINET

- completely welded steel sheet construction
- 2 doors, with 4 height-adjustable shelves
- load capacity 50 kg per shelf
- doors strengthened and 3-point safety lock
- rotary handle with cylinder lock
- powder coated, ELORA-yellow (RAL 1006) doors black (RAL 9005)



Code	Number	Width mm	Height mm	Depth mm	Pieces	Weight/g
1227000006000	1227-L	950	1900	500	1	83000

1100L
TOOL CABINET

- 2 doors, with 2 drawers
- lockable with cylinder lock
- powder coated, ELORA-yellow (RAL 1006), doors black (RAL 9005)
- stable steel sheet version
- suitable assortments: all OMS-Modules



Code	Number	Width mm	Height mm	Depth mm	suitable assortments	Pieces	Weight/g
1100520001000	1100L	690	1000	290	WS-1 to 5	1	26000

1815

WORK TABLE, FOLDABLE

- ▶ for mobile use, foldable to measurement H 140, W 1000, D 700 mm
- ▶ strong, multiple glued beech wood working surface
- ▶ rack made of steel tube, scratch-resistant ELORA yellow lacquered



Code	Number	Height mm	Width mm	Depth mm	Loading Capacity kg	Pieces	Weight/g
1815010001000	1815	820	1000	700	500	1	26000

800L/810L

CANTILEVER TOOL BOX WITH 5 TRAYS

- ▶ blue lacquered, to be locked with padlock ELORA-No. 256
- ▶ heavy gauge sheet steel



Code+	Number	Width mm	Height mm	Depth mm	suitable assortments	Pieces	Weight/g
0800520031000	800L	430	200	200	WS-1, 9	1	4300
0810510031000	810L	530	200	200	WS-1, 2, 3, 4, 8, 9, 10	1	5200

803L/813L

CANTILEVER TOOL BOX WITH 3 TRAYS

- ▶ blue lacquered, to be locked with padlock ELORA-No. 256
- ▶ heavy gauge sheet steel



Code	Number	Width mm	Height mm	Depth mm	suitable assortments	Pieces	Weight/g
0803510036000	803L	430	150	195	WS-1, 9	1	3300
0813510036000	813L	530	150	195	WS-1, 9	1	3600

256

PADLOCK

- ▶ for cantilever tool box ELORA-No.800L, 803L, 810L and 813L
- ▶ with steel bow 29 mm, incl. 2 keys
- ▶ Brass



Code	Number	Width mm	Pieces	Weight/g
0256000000000	256	43,8	1	80

1380-L

HARD PROTECTIVE CASE

- variable dividable floor shell
- removable cover board with 15 tool pockets
- removable tool board with 22 tool pockets on the front and back
- document compartment in the lid (A4 format)
- 2 lockable clip locks made of metal
- hinge cover
- robust aluminium frame with protection for the sharp edges
- trolley case made of dent proof black ABS material
- **delivery without tools**



Code	Number	Internal measurements WxDxH mm	External measurements WxDxH mm	max. bearing load	suitable assortments	Pieces	Weight/g
1380000000000	1380-L	460x315x169	490x365x188	25	WS-4, 6, 8, 9, 10	1	5000

1381-L

HARD PROTECTIVE TROLLEY CASE

- mobile case with telescopic handle and 2 free running rollers
- variable dividable floor shell
- removable cover board with 15 tool pockets
- removable tool board with 23 tool pockets on the front and back
- document compartment in the lid (A4 format)
- 2 lockable clip locks made of metal and additional combination lock
- hinge cover
- robust aluminium frame with protection for the sharp edges
- trolley case made of dent proof black ABS material
- **delivery without tools**



Code	Number	Internal measurements WxDxH mm	External measurements WxDxH mm	max. bearing load	Volume l	suitable assortments	Pieces	Weight/g
1381000000000	1381-L	485x375x200	515x440x225	30	36	WS-4, 6, 8, 9, 10	1	6280

1386-L

TECHNICIANS NOTEBOOK TOOL BAG

- padded lap-top compartment (17") and additional document compartment (A4 format)
- removable tool board with 8 pockets on the front and 2 rows elastic hangers on the back
- 2 small and 5 big pockets on the inside
- key ring holder
- front side 90 ° foldable
- on each side big attached pocket with hook and loop fastener
- splash proofed bottom
- adjustable strap with shoulder cushion quick fastener
- handle double fixable
- made of tear-proofed black nylon
- **delivery without tools and accessories**



Code	Number	Internal measurements WxDxH mm	External measurements WxDxH mm	max. bearing load	Pieces	Weight/g
1386000000000	1386-L	440x320x180	450x340x200	12	1	2380

1385-L

INSTALLATION TOOL BAG

- robust tool bag with moisture repellent bottom
- solid metal handle with padded grip
- removable cover and padded carrying strap
- outside 5 compartments with hook and loop fastener, fixation for water level
- inside 10 pockets an 8 hangers
- made of tear-proofed durable black nylon
- **delivery without tools**



Code	Number	Internal measurements WxDxH mm	External measurements WxDxH mm	max. bearing load	suitable assortments	Pieces	Weight/g
1385000000000	1385-L	400x190x240	450x250x270	12	WS-6, 9, 10	1	2820

OMS-47

MODULE-AUTOMOTIVE-TIRE AND BRAKE ASSORTMENT

- for ELORA-roller tool cabinets
- black, with yellow signal colour
- oil and grease resistant
- chemical resistant
- Width: 41,0 cm, Depth: 57,3 cm
- hard foam insert

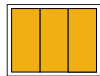
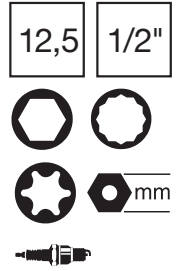

Code	Number	Contents	Pieces	Weight/g
0000414701000	OMS-47	Combination Spanner with Ring Ratchet, reversible 204-J 8, 10, 12, 13, 17, 19 mm Double-Ended Ring Spanner for outside TORX®-Screws 119TXE- 6×8, 10×12, 14×18, 20×24 mm Open Ring Spanner 121-10×11 mm Adjustable Wrench 60-12MB Spark Plug Socket 1/2" 771-LTZ 16, 18, 20,8 mm Socket Converter 770-L14, 1/2" 3/8" Impact Socket 1/2" 790LTP-17, 19, 21 mm Torque Wrench with Vernier Scale 2179-60 10-60 Nm, 2179-200 40-200 Nm Engineer's Hammer, German Pattern 1665-500 Feeler Gauge 188-13M Tyre Lever 165-300, 165-500 Brush for Brake Service 293BS Seal Flat Scraper 290-1	1	6565
0000414707000	OMS-47L	empty module	1	180

OMS-50

MODULE-SPANNER SET

- for ELORA-roller tool cabinets
- black, with yellow signal colour
- oil and grease resistant
- chemical resistant
- Width: 41,0 cm, Depth: 57,3 cm
- hard foam insert

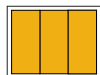
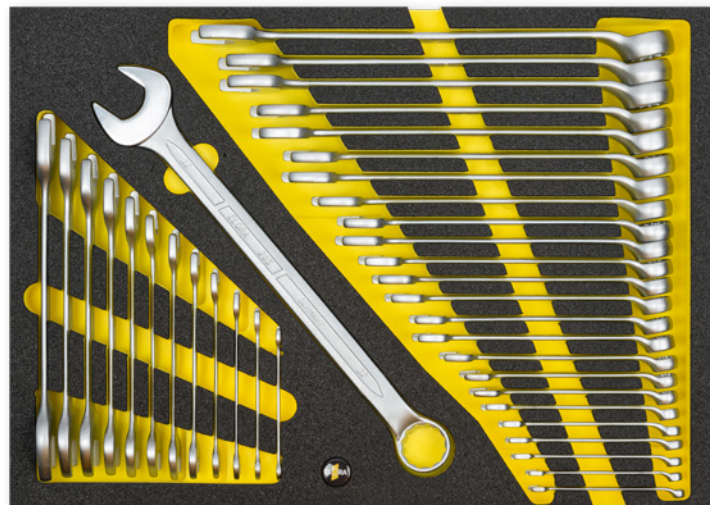

Code	Number	Contents	Pieces	Weight/g
0000415001000	OMS-50	Combination Spanners, cranked 205- 6, 7, 8, 9, 10, 11, 12, 13, 14, 15, 16, 17, 18, 19, 20, 21, 22, 23, 24, 25, 26, 27, 28, 30, 32 mm Double Open-Ended Spanners DIN 3110 100- 6×7, 8×9, 10×11, 12×13, 14×15, 16×17, 18×19, 20×22, 21×23, 24×27, 25×28, 30×32 mm	1	8010
0000415007000	OMS-50L	empty module	1	160

OMS-15

MODULE-DOUBLE OPEN ENDED SPANNER

- ▶ for ELORA-roller tool cabinets
- ▶ black, with yellow signal colour
- ▶ oil and grease resistant
- ▶ chemical resistant
- ▶ Width: 41,0 cm, Depth: 18,9 cm
- ▶ hard foam insert

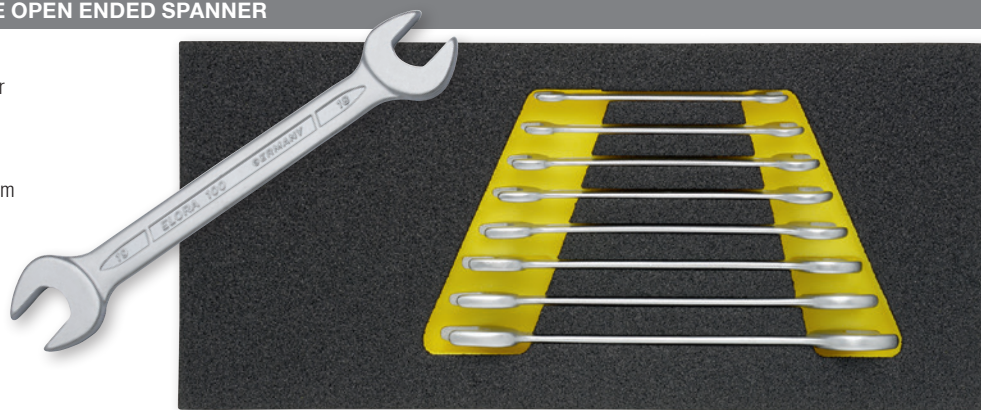

mm

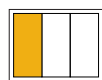

Code	Number	Contents	Pieces	Weight/g
0000411501000	OMS-15	Double Open-Ended Spanners DIN 3110 100- 6×7, 8×9, 10×11, 12×13, 14×15, 16×17, 18×19, 20×22 mm	1	900
0000411507000	OMS-15L	empty module	1	80

OMS-1

MODULE-COMBINATION SPANNERS, CRANKED

- ▶ for ELORA-roller tool cabinets
- ▶ black, with yellow signal colour
- ▶ oil and grease resistant
- ▶ chemical resistant
- ▶ Width: 41,0 cm, Depth: 18,9 cm
- ▶ hard foam insert

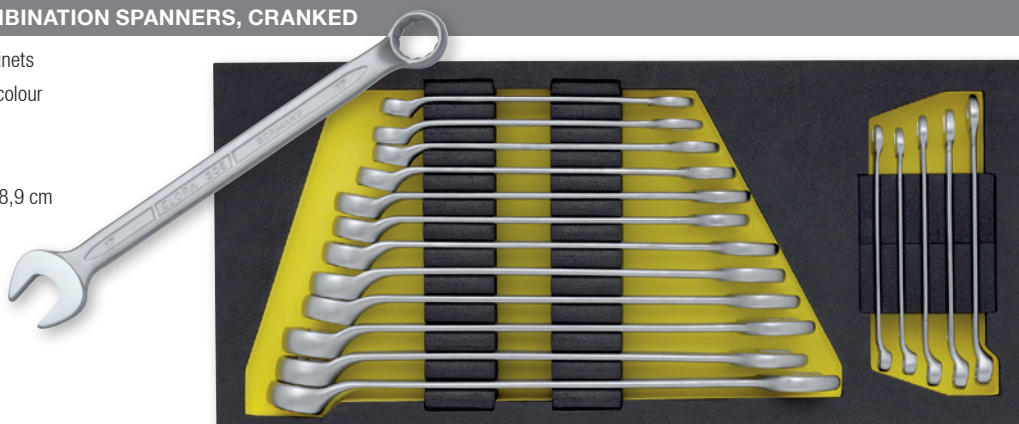

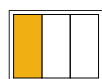
 mm

Code	Number	Contents	Pieces	Weight/g
0000410101000	OMS-1	Combination Spanners, cranked 205- 6, 7, 8, 9, 10, 11, 12, 13, 14, 15, 16, 17, 18, 19, 20, 21, 22 mm	1	1990
0000410107000	OMS-1L	empty module	1	70

OMS-51

MODULE-SPANNER SET

- ▶ for ELORA-roller tool cabinets
- ▶ black, with yellow signal colour
- ▶ oil and grease resistant
- ▶ chemical resistant
- ▶ Width: 41,0 cm, Depth: 57,3 cm
- ▶ hard foam insert

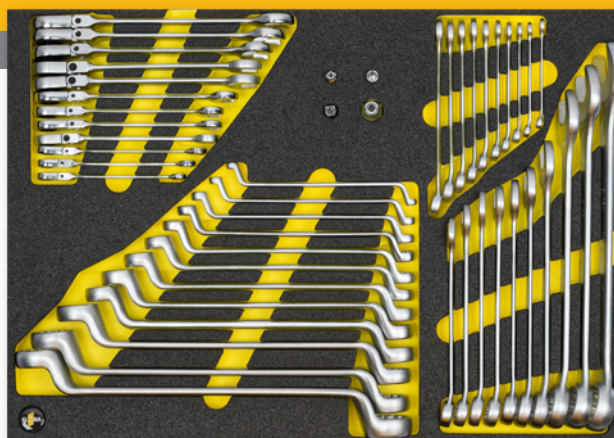

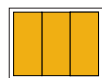
 mm

Code	Number	Contents	Pieces	Weight/g
0000415101000	OMS-51	Combination Spanners, bent 203- 6, 7, 8, 9, 10, 11, 12, 13, 14, 15, 16, 17, 18, 19, 21, 22, 24, 27, 30, 32, mm Double-Ended Ring Spanners, DIN 838 110- 6×7, 8×9, 10×11, 12×13, 14×15, 16×17, 18×19, 20×22, 21×23, 24×27, 25×28, 30×32 mm Combination Spanner with Joint-Ring Ratchet 204R- 8, 9, 10, 11, 12, 13, 14, 15, 16, 17, 18, 19 mm Adapter Drives for bits 1/4", 3/8", 1/2" und 1/4" Bit-Adaptor 118- 1, 2, 3, 4	1	8100
0000415107000	OMS-51L	empty module	1	160

OMS-9

MODULE-COMBINATION SPANNER, BENT

- for ELORA-roller tool cabinets
- black, with yellow signal colour
- oil and grease resistant
- chemical resistant
- Width: 41,0 cm, Depth: 18,9 cm
- hard foam insert

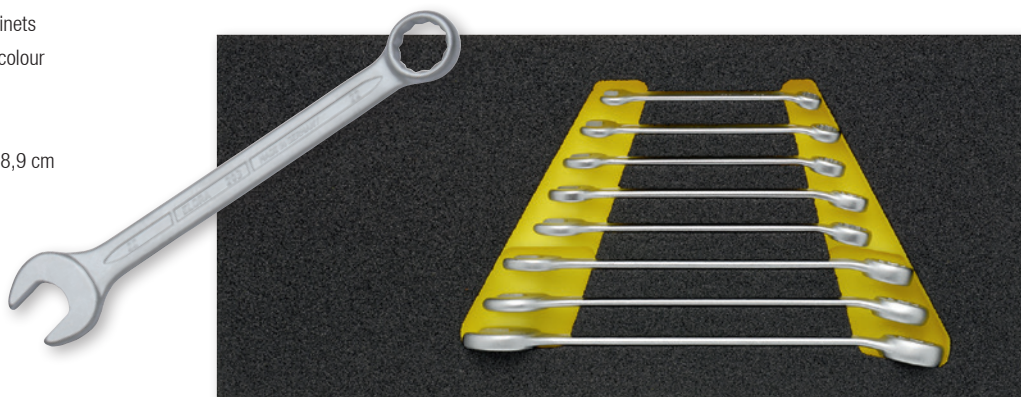

Code	Number	Contents	Pieces	Weight/g
0000410901000	OMS-9	Combination Spanners, bent 203- 8, 10, 11, 13, 14, 17, 19, 22 mm	1	690
0000410907000	OMS-9L	empty module	1	80

OMS-22

MODULE-COMBINATION SPANNER, BENT

- for ELORA-roller tool cabinets
- black, with yellow signal colour
- oil and grease resistant
- chemical resistant
- Width: 41,0 cm, Depth: 18,9 cm
- hard foam insert

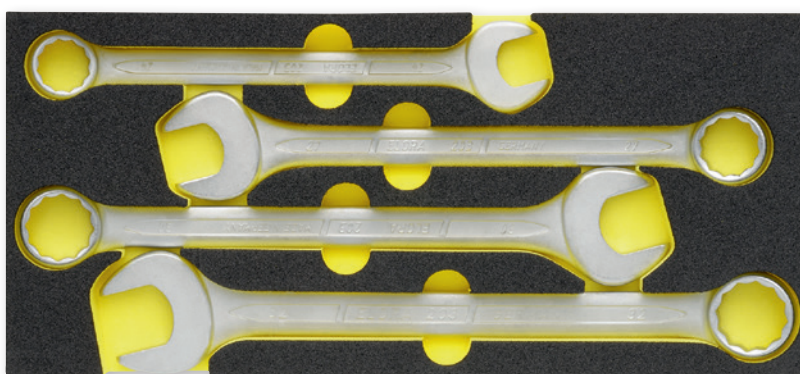

Code	Number	Contents	Pieces	Weight/g
0000412201000	OMS-22	Combination Spanners, bent 203- 24, 27, 30, 32 mm	1	1820
0000412207000	OMS-22L	empty module	1	60

OMS-30

MODULE-COMBINATION SPANNER WITH RING RATCHET

- for ELORA-roller tool cabinets
- black, with yellow signal colour
- oil and grease resistant
- chemical resistant
- Width: 41,0 cm, Depth: 18,9 cm
- hard foam insert



Code	Number	Contents	Pieces	Weight/g
0000413001000	OMS-30	Combination Spanners with Ring Ratchet 204- 8, 9, 10, 12, 13, 14, 17, 19 mm Adapter Drives for bits für 1/4", 3/8", 1/2" und 1/4" Bit-Adaptor 118- 1, 2, 3, 4	1	933
0000413007000	OMS-30L	empty module	1	80

OMS-33

MODULE-COMBINATION SPANNER WITH RING RATCHET, REVERSIBLE

- for ELORA-roller tool cabinets
- black, with yellow signal colour
- oil and grease resistant
- chemical resistant
- Width: 41,0 cm, Depth: 18,9 cm
- hard foam insert

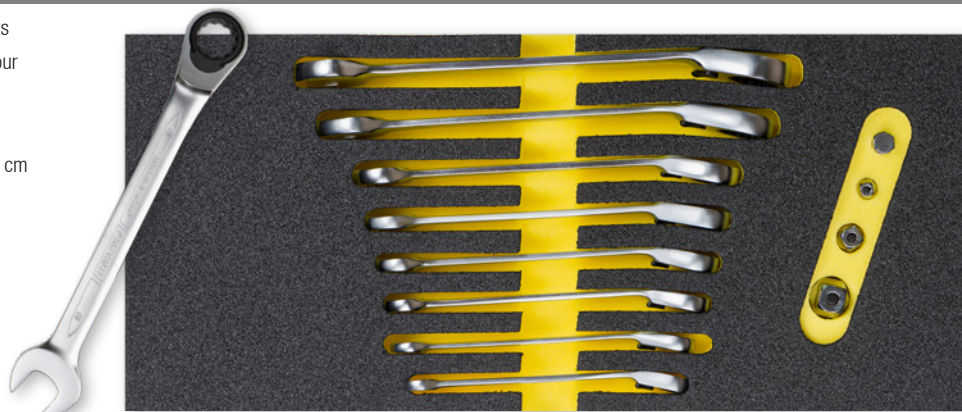

Code	Number	Contents	Pieces	Weight/g
0000413301000	OMS-33	Combination Spanner with Ring Ratchet, reversible 204J- 8, 9, 10, 12, 13, 14, 17, 19 mm Adapter Drives for bits für 1/4", 3/8", 1/2" und 1/4" Bit-Adaptor 118- 1, 2, 3, 4	1	998
0000413307000	OMS-33L	empty module	1	80

OMS-32

MODULE-COMBINATION SPANNER WITH JOINT-RING RATCHET

- for ELORA-roller tool cabinets
- black, with yellow signal colour
- oil and grease resistant
- chemical resistant
- Width: 41,0 cm, Depth: 18,9 cm
- hard foam insert



Code	Number	Contents	Pieces	Weight/g
0000413201000	OMS-32	Combination Spanner with Joint-Ring Ratchet 204R- 8, 9, 10, 12, 13, 14, 17, 19 mm Adapter Drives for bits für 1/4", 3/8", 1/2" und 1/4" Bit-Adaptor 118- 1, 2, 3, 4	1	980
0000413207000	OMS-32L	empty module	1	80

OMS-19

MODULE-DOUBLE-ENDED RING SPANNER

- for ELORA-roller tool cabinets
- black, with yellow signal colour
- oil and grease resistant
- chemical resistant
- Width: 41,0 cm, Depth: 18,9 cm
- hard foam insert

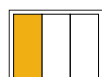
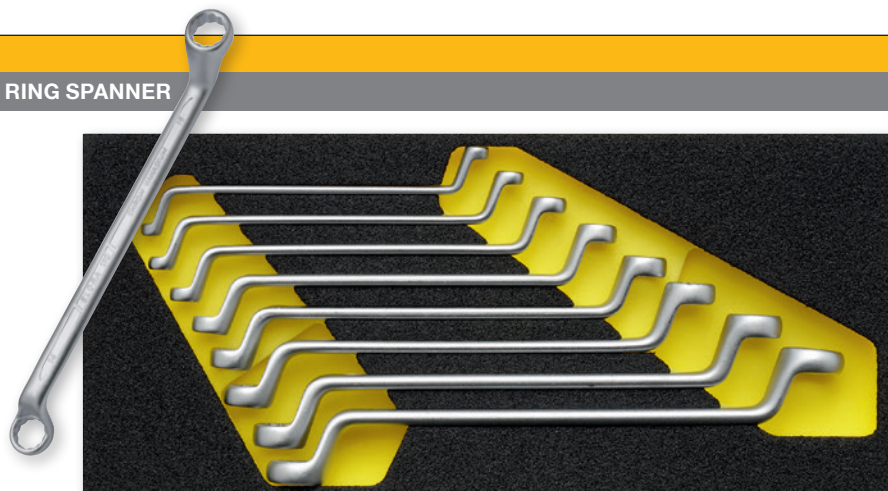

Code	Number	Contents	Pieces	Weight/g
0000411901000	OMS-19	Double-Ended Ring Spanners, DIN 838 110- 6x7, 8x9, 10x11, 12x13, 14x15, 16x17, 18x19, 20x22 mm	1	1350
0000411907000	OMS-19L	empty module	1	70

OMS-28
MODULE-RATCHET RING SPANNER

- for ELORA-roller tool cabinets
- black, with yellow signal colour
- oil and grease resistant
- chemical resistant
- Width: 41,0 cm, Depth: 18,9 cm
- hard foam insert

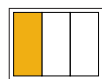
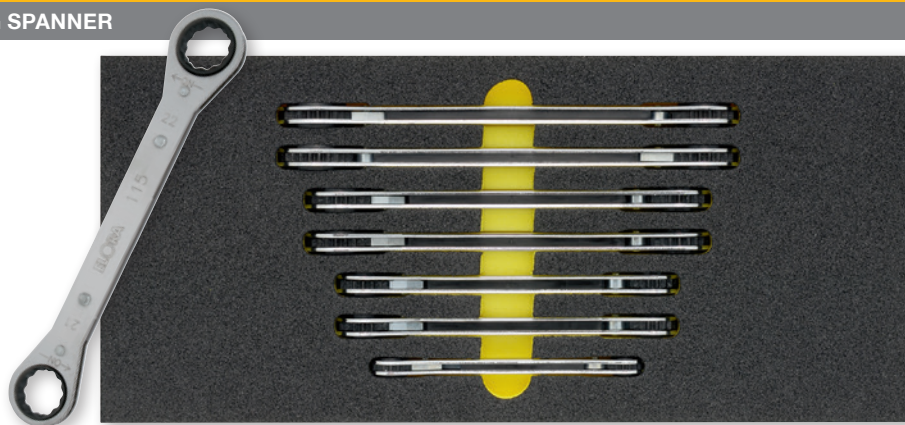

Code	Number	Contents	Pieces	Weight/g
0000412801000	OMS-28	Ratchet Ring Spanners, straight 115 - 8×9, 10×11, 12×13, 14×15, 16×17, 18×19, 21×22 mm	1	1330
0000412807000	OMS-28L	empty module	1	80

OMS-29
MODULE-RATCHET RING SPANNERS, BENT

- for ELORA-roller tool cabinets
- black, with yellow signal colour
- oil and grease resistant
- chemical resistant
- Width: 41,0 cm, Depth: 18,9 cm
- hard foam insert

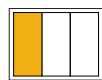
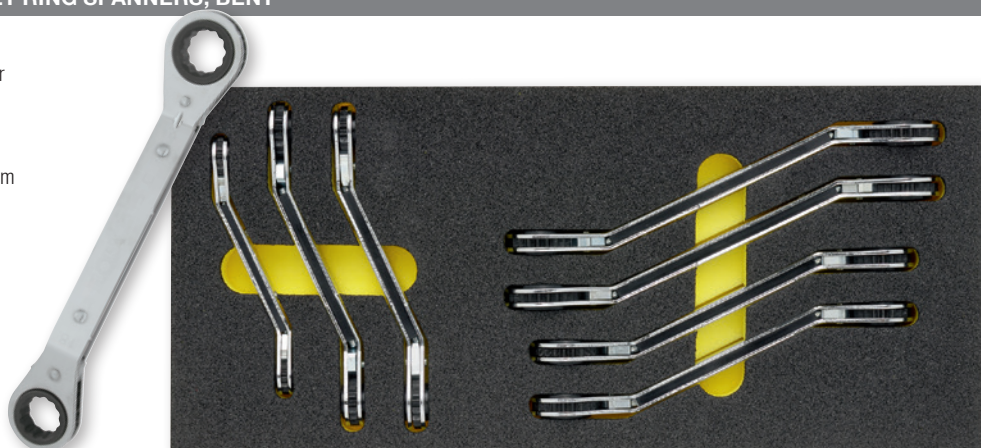

Code	Number	Contents	Pieces	Weight/g
0000412901000	OMS-29	Ratchet Ring Spanners, bent 115G - 8×9, 10×11, 12×13, 14×15, 16×17, 18×19, 21×22 mm	1	1340
0000412907000	OMS-29L	empty module	1	80

OMS-31
MODULE-FLARE NUT OPEN ENDED RING SPANNER

- for ELORA-roller tool cabinets
- black, with yellow signal colour
- oil and grease resistant
- chemical resistant
- Width: 41,0 cm, Depth: 18,9 cm
- hard foam insert

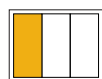
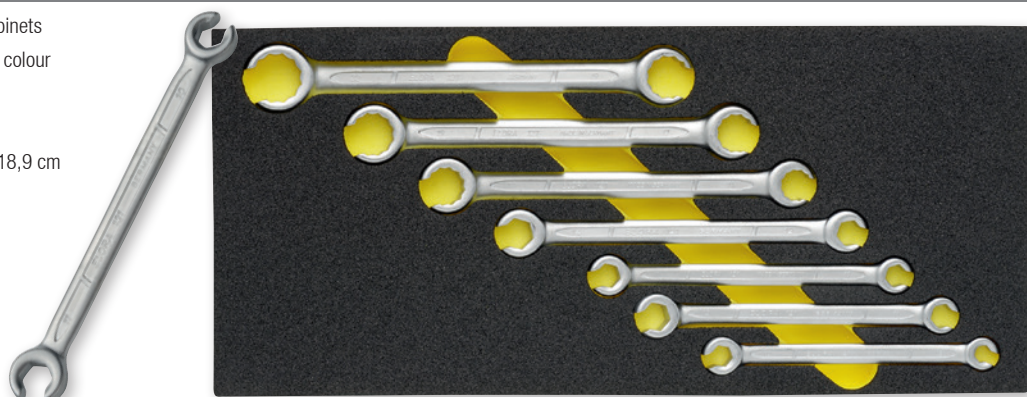

Code	Number	Contents	Pieces	Weight/g
0000413101000	OMS-31	Ended Ring Spanners for flare nuts 121 - 8x10, 10x11, 11x13, 12x14, 14x17, 17x19, 19x22 mm	1	850
0000413107000	OMS-31L	empty module	1	80

OMS-46

MODULE-SOCKET SET 1/4" AND 1/2"

- ▶ for ELORA-roller tool cabinets
- ▶ black, with yellow signal colour
- ▶ oil and grease resistant
- ▶ chemical resistant
- ▶ Width: 41,0 cm, Depth: 57,3 cm
- ▶ hard foam insert

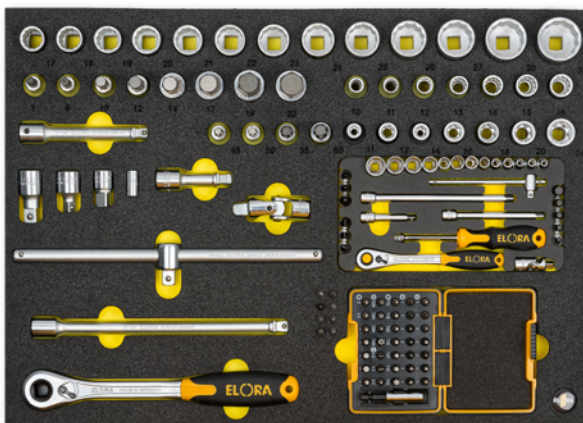

6,3 12,5

1/4" 1/2"

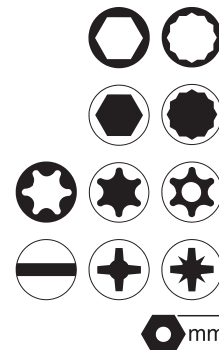

mm

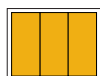

Code	Number	Contents	Pieces	Weight/g	
0000414601000	OMS-46	1440-MU Socket Set 1/4", 30 pcs. ○ ● ⊖ ⊕ Bitbox 1/4", 36 pcs. ⊖ ⊕ ⊕ ⊕ ⊕ ⊕ Screwdriver Bit 1/4" for Inside TORX® Screws ★ 3050-TX 6, 7, 8, TX 9, TX 10 Screwdriver Bit 1/4" for Inside TORX® Safety Screws ☆ 3070-TTX 10, 15, 27 Socket Converter 1/4" 1450-16, 1/4" ○ 1/4" ○ Bihexagon Sockets 1/2" ○ 770-LM 10, 11, 12, 13, 14, 15, 16, 17, 18, 19, 20, 21, 22, 23, 24, 25, 26, 27, 30, 32 mm Reversible Ratchet 1/2" 770-L1D Sliding T-Bar 1/2" 770-L3	Extension Bar 1/2" 50 mm 770-L35 Extension Bar 1/2", swivelling 75 mm 770-L4V Extension Bar 1/2", swivelling 125 mm 770-L5V Extension Bar 1/2", swivelling 250 mm 770-L6V Universal Joint 1/2" 770-L7 Socket Converter 1/2" 770-L13, 3/8" ■ 1/2" ○ Socket Converter 1/2" 770-L14, 1/2" ■ 3/8" ○ Screwdriver Sockets 1/2" for inside Hexagon Screws ● 3210-IN 7, IN 8, IN 10, IN 12, IN 14, IN 17, IN 19, IN 22 Screwdriver Sockets 1/2" for Inside TORX® Screws ★ 3245-TX 45, TX 50, TX 55, TX 60 Sockets 1/2" for Outside TORX® Screws ☆ 770-LTXE 11, 12, 14, 16, 18, 20, 24 mm	1	6540
0000414607000	OMS-46L	empty module	1	180	

OMS-52

MODULE-SOCKET SET, DEEP 1/4" AND 1/2"

- ▶ for ELORA-roller tool cabinets
- ▶ black, with yellow signal colour
- ▶ oil and grease resistant
- ▶ chemical resistant
- ▶ Width: 41,0 cm, Depth: 57,3 cm
- ▶ hard foam insert

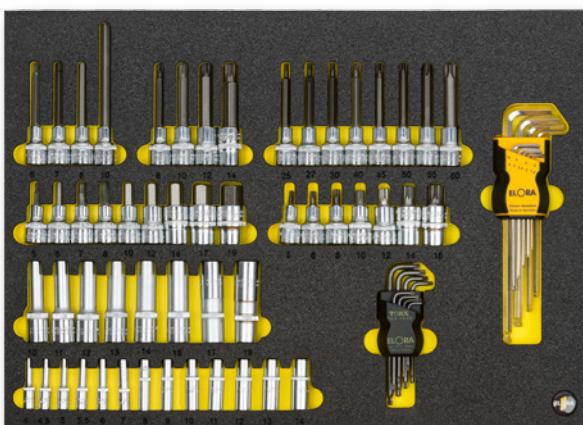

6,3 12,5

1/4" 1/2"

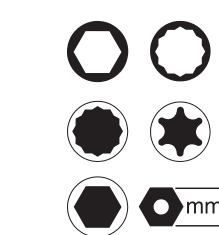

mm

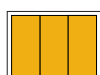

Code	Number	Contents	Pieces	Weight/g	
0000415201000	OMS-52	Hexagon Sockets, extra deep 1/4" ○ 1455-T 4, 4,5, 5, 5,5, 6, 7, 8, 9, 10, 11, 12, 13, 14 mm Hexagon Sockets, extra deep 1/2" ○ 771-LT 10, 11, 12, 13, 14, 15, 17, 19 mm Screwdriver Sockets 1/2" for inside Hexagon Screws ● 3210-IN 5, IN 6, IN 7, IN 8, IN 10, IN 12, IN 14, IN 17, IN 19 Screwdriver Sockets 1/2", long for inside Hexagon Screws ● 3210-INL 6x100, INL 7x100, INL 8x100, INL 10x140 Screwdriver Sockets 1/2", long for inside-TORX®-Screws ★ 3245-TXL 25, TXL 27, TXL 30, TXL 40, TXL 45, TXL 50, TXL 55, TXL 60	Screwdriver Sockets 1/2" for inside multi-point B & S and XZN ● 3230-XZN 5, XZN 6, XZN 8, XZN 10, XZN 12, XZN 14, XZN 16 Screwdriver Sockets 1/2", long for inside multi-point B & S and XZN ● 3230-XZNL 8x100, XZNL 10x100, XZNL 12x100, XZNL 14x100 159SKU Ball End Hexagon Key Set, extra long, 1,5-10 mm ● 162S-TXKU TORX®-Ball End Key Set, TX 9-40 ★	1	5370
0000415207000	OMS-52L	empty module	1	160	

OMS-2
MODULE-SOCKET SET 1/4"

- for ELORA-roller tool cabinets
- black, with yellow signal colour
- oil and grease resistant
- chemical resistant
- Width: 41,0 cm, Depth: 18,9 cm
- hard foam insert

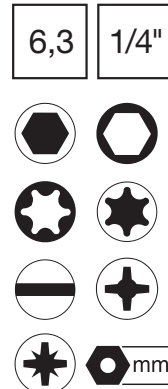

Code	Number	Contents	Pieces	Weight/g
0000410201000	OMS-2	Hexagon Sockets 1/4" ○ 1455-4, 4,5, 5, 5,5, 6, 7, 8, 9, 10,11, 12, 13, 14 mm Screwdriver Sockets for plain slotted screws ◄ 1455-IS 0,8x4, 1,0x5,5, 1,6x8,0 mm Screwdriver Sockets for cross slotted screws ⊕ 1455-PH 1, PH 2, PH 3, PH 4 Screwdriver Sockets for cross slotted screws ⊕ 1455-PZ 1, PZ 2 Screwdriver Sockets for inside hexagon screws ● 1455-IN 3, 4, 5, 6, 8 mm Sockets for outside TORX® screws ⊕ 1455-TXE 4, 5, 6, 7, 8, 10,11	1 1480	1 1480
0000410207000	OSM-2L	empty module	1	80

OMS-49
MODULE-SOCKET SET 3/8"

- for ELORA-roller tool cabinets
- black, with yellow signal colour
- oil and grease resistant
- chemical resistant
- Width: 41,0 cm, Depth: 37,7 cm
- hard foam insert

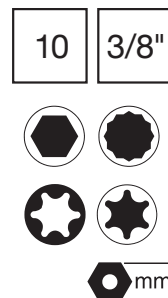
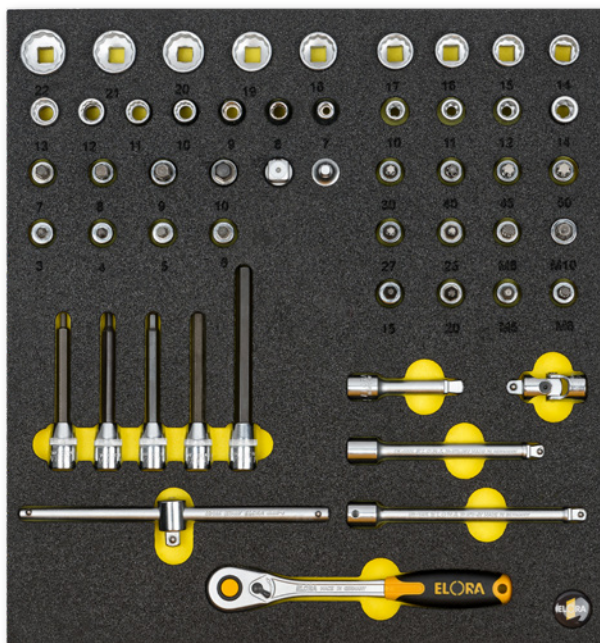

Code	Number	Contents	Pieces	Weight/g
0000414901000	OMS-49	Bi-Hexagon Sockets ○ 870- 7, 8, 9, 10, 11, 12, 13, 14, 15, 16, 17, 18, 19, 20, 21, 22 mm Screwdriver Sockets ● 3510-IN 3, 4, 5, 6, 7, 8, 9, 10 Screwdriver Sockets long for inside hexagon screws ● 3510-INL 4x100, 5x100, 6x100, 8x100, 10x130 Screwdriver Sockets for inside-TORX® screws ★ 3244-TX 15, 20, 25, 27, 30, 40, 45, 50 Screwdriver Sockets for inside multi-point B & S and XZN screws ● 3530-XZN 5, 6, 8, 10	1 3165	1 3165
0000414907000	OSM-49L	empty module	1	160

OMS-34/21

MODULE - SOCKET SET 3/8"

- for ELORA-roller tool cabinets
- black, with yellow signal colour
- oil and grease resistant
- chemical resistant
- Width: 41,0 cm, Depth: 18,9 cm
- hard foam insert

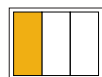

Code	Number	Contents	Pieces	Weight/g
0000413401000	OMS-34	Bi-Hexagon Sockets 870- 7, 8, 9, 10, 11, 12, 13, 14, 15, 16, 17, 18, 19, 20, 21, 22 mm ○ Reversible Ratchet 870-1D Extension Bar 125 mm 870-35 Extension Bar 250 mm 870-55 Universal Joint 870-9	1	1340
0000412101000	OMS-21	same as OMS-34, but all sockets in hexagon pattern ○	1	1340
0000412107000	OMS-21/34L	empty module	1	80

OMS-3/4

MODULE-SOCKET SET 1/2"

- for ELORA-roller tool cabinets
- black, with yellow signal colour
- oil and grease resistant
- chemical resistant
- Width: 41,0 cm, Depth: 18,9 cm
- hard foam insert

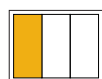
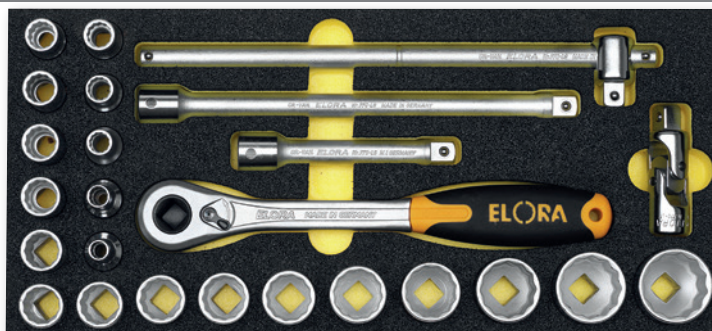

Code	Number	Contents	Pieces	Weight/g
0000410301000	OMS-3	Bi-Hexagon Sockets 770-LM 8, 9, 10, 11, 12, 13, 14, 15, 16, 17, 18, 19, 20, 21, 22, 24, 25, 27, 30, 32 mm ○ Reversible Ratchet 770-L1D Sliding T-Bar 770-L3 Extension Bar 125 mm 770-L5 Extension Bar 250 mm 770-L6 Universal Joint 770-L7	1	3420
0000410401000	OMS-4	same as OMS-3, but all sockets in hexagon pattern ○	1	3400
0000410307000	OMS-3/4L	empty module	1	80

OMS-35/25

MODULE-SOCKET SET 3/4"

- for ELORA-roller tool cabinets
- black, with yellow signal colour
- oil and grease resistant
- chemical resistant
- Width: 41,0 cm, Depth: 37,7 cm
- hard foam insert

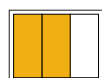
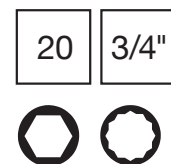
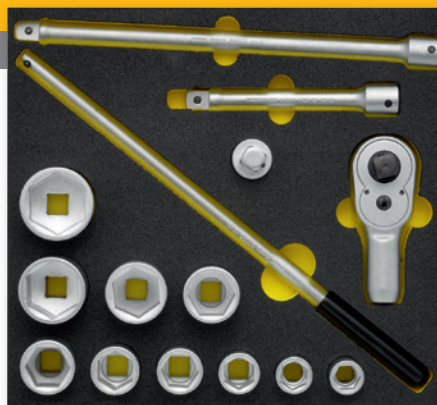

Code	Number	Contents	Pieces	Weight/g
0000413501000	OMS-35	Bi-Hexagon Sockets 770-S 22, 24, 27, 30, 32, 36, 38, 41, 46, 50 mm ○ Reversible Ratchet Head 770-S1K Extension Bar 200 mm 770-S4 Extension Bar 400 mm 770-S5 Tommy Bar 770-S7 Sliding Head 770-S13	1	9280
0000412501000	OMS-25	same as OMS-35, but all sockets in hexagon pattern ○	1	9280
0000412507000	OMS-25/35L	empty module	1	125

OMS-24

MODULE-IMPACT-SOCKET SET 1/2"

- for ELORA-roller tool cabinets
- black, with yellow signal colour
- oil and grease resistant
- chemical resistant
- Width: 41,0 cm, Depth: 18,9 cm
- hard foam insert

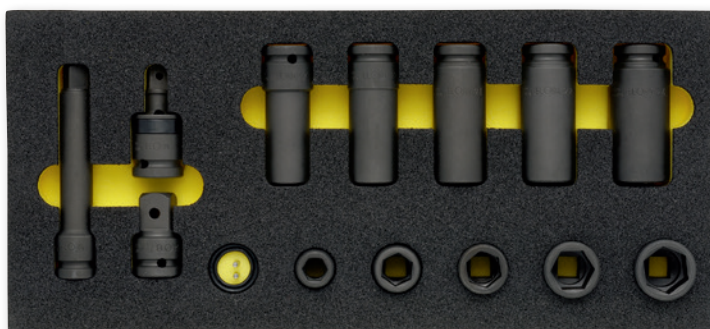

12,5

1/2"

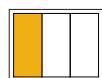

Code	Number	Contents	Pieces	Weight/g
0000412401000	OMS-24	Impact Sockets 790-13, 17, 19, 22, 24 mm ○ Impact Sockets extra deep 790LT-17, 19, 21, 22, 24 mm ○ Impact Extension Bar 7901-125 Impact Adaptor 7902-3/4, 3/4" ■ 1/2" ○ Impact Universal Joint 795 -1/2 Impact Locking pins 7903-20, 25 Impact Locking rings 7904-20, 24	1	2900
0000412407000	OMS-24L	empty module	1	80

OMS-23

MODULE-IMPACT-SOCKET SET 3/4"

- for ELORA-roller tool cabinets
- black, with yellow signal colour
- oil and grease resistant
- chemical resistant
- Width: 41,0 cm, Depth: 37,7 cm
- hard foam insert



20

3/4"

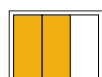

Code	Number	Contents	Pieces	Weight/g
0000412301000	OMS-23	Impact Sockets 791-24, 27, 30, 32, 36 mm ○ Impact Sockets extra deep 791LT-17, 19, 24, 27, 30, 32 mm ○ Impact Adaptor 7912-1/2, 1/2" ■ 3/4" ○ Impact Universal Joint 795 -3/4 Impact Locking pins 7913-29, 37 Impact Locking rings 7914-28, 36	1	7780
0000412307000	OMS-23L	empty module	1	125

OMS-18

MODULE-TORX®-TOOLS

- for ELORA-roller tool cabinets
- black, with yellow signal colour
- oil and grease resistant
- chemical resistant
- Width: 41,0 cm, Depth: 18,9 cm
- hard foam insert



12,5

1/2"

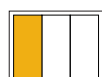

Code	Number	Contents	Pieces	Weight/g
0000411801000	OMS-18	Screwdriver Sockets for inside TORX® screws 3245 TX 20, 25, 27, 30, 40, 45, 50, 55, 60 ☉ TORX®-Ball End Key Set 162S-TXKU 9, 10, 15, 20, 25, 27, 30, 40 ☼	1	980
0000411807000	OMS-18L	empty module	1	80

OMS-26

MODULE HEXAGON KEY SET

- for ELORA-roller tool cabinets
- black, with yellow signal colour
- oil and grease resistant
- chemical resistant
- Width: 41,0 cm, Depth: 18,9 cm
- hard foam insert

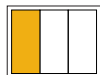
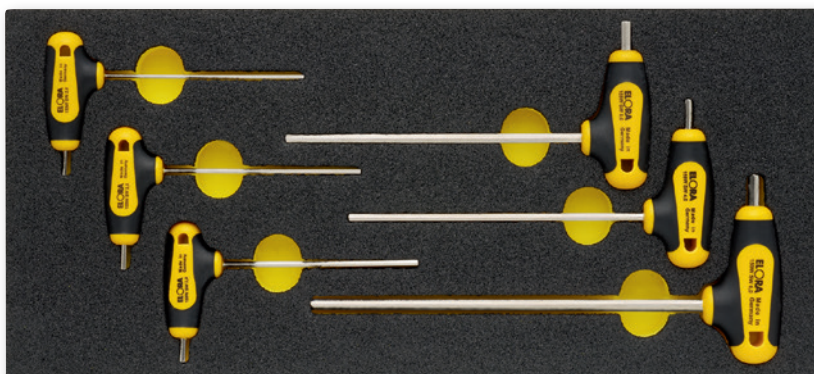

Code	Number	Contents	Pieces	Weight/g
0000412601000	OMS-26	Hexagon Key with T-Handle ● 159W-2, 2,5, 3, 4, 5, 6	1	340
0000412607000	OMS-26L	empty module	1	80

OMS-27

MODUL-TORX®-KEY SET WITH T-HANDLE

- for ELORA-roller tool cabinets
- black, with yellow signal colour
- oil and grease resistant
- chemical resistant
- Width: 41,0 cm, Depth: 18,9 cm
- hard foam insert

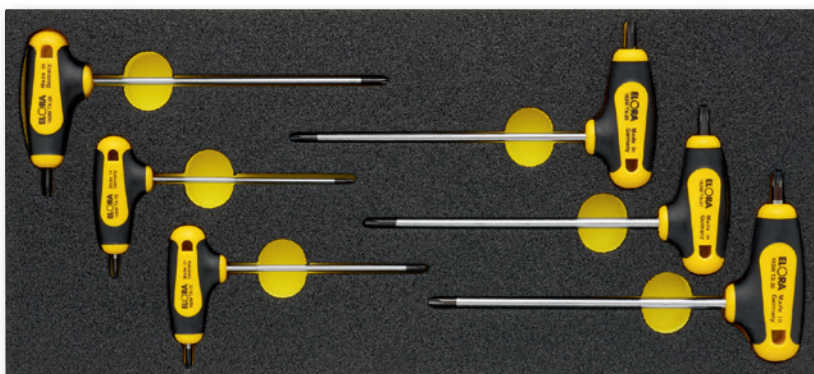

Code	Number	Contents	Pieces	Weight/g
0000412701000	OMS-27	TORX®-Key with T-Handle ★ 162WTX-10, 15, 20, 25, 27, 30	1	360
0000412707000	OMS-27L	empty module	1	80

OMS-48
MODULE-SCREWDRIVERS

- for ELORA-roller tool cabinets
- black, with yellow signal colour
- oil and grease resistant
- chemical resistant
- Width: 41,0 cm, Depth: 57,3 cm
- hard foam insert

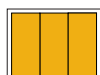
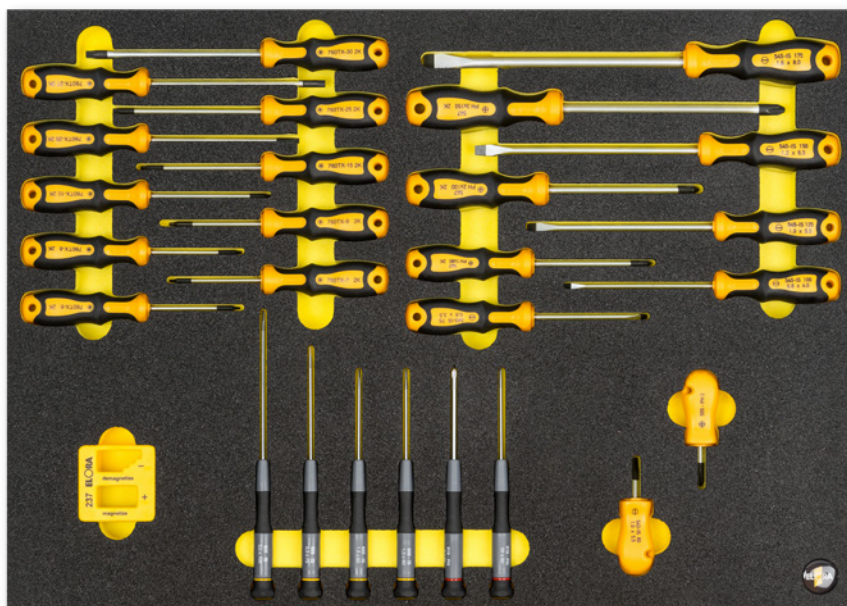

Code	Number	Contents	Pieces	Weight/g
0000414801000	OMS-48	QUATROLIT®-2C-Screwdriver for plain slotted screws 545-IS 75, 100, 125, 150, 175 Screwdriver for plain slotted screws, short version 543-IS 60 Screwdriver for cross slotted screws, short version 555-PH 2 QUATROLIT®-2C-Screwdriver for cross slotted screws 547-PH 1, 2, 3 Electronic Screwdriver for plain slotted screws 600-IS 1,5x60, 1,8x60, 2,5x75, 3,0x100 Electronic Screwdriver for cross slotted screws 610-PH 00, PH 0 Screwdriver for Inside TORX® screws 760TX-6, 7, 8, 9, 10, 15, 20, 25, 27, 30 Magnetizer-Demagnetizer 237	1	1410
0000414807000	OMS-48L	empty module	1	160

OMS-11
MODULE-QUATROLIT®-2C-SCREWDRIVERS

- for ELORA-roller tool cabinets
- black, with yellow signal colour
- oil and grease resistant
- chemical resistant
- Width: 41,0 cm, Depth: 18,9 cm
- hard foam insert

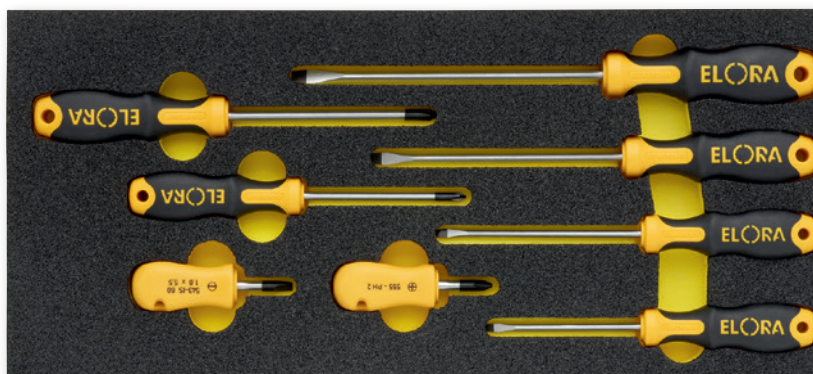

Code	Number	Contents	Pieces	Weight/g
0000411101000	OMS-11	QUATROLIT®-2C-Screwdriver for plain slotted screws 545-IS 75, 100, 125, 150 QUATROLIT®-2C-Screwdriver for cross slotted screws 547-PH 1, 2 Screwdriver for plain slotted screws, short version 543-IS 45 Screwdriver for cross slotted screws, short version 555-PH 1	1	485
0000411107000	OMS-11/38L	empty module	1	80

OMS-6

MODULE-QUATROLIT®-2C-SCREWDRIVERS

- ▶ for ELORA-roller tool cabinets
- ▶ black, with yellow signal colour
- ▶ oil and grease resistant
- ▶ chemical resistant
- ▶ Width: 41,0 cm, Depth: 18,9 cm
- ▶ hard foam insert



Code	Number	Contents	Pieces	Weight/g
0000410601000	OMS-6	QUATROLIT®-2C Screwdriver for plain slotted screws 539-IS 90, 100, 125, 150 649-IS 75 ⊖ QUATROLIT®-2C Screwdriver for cross slotted screws 559-PH 1, 2, 3 ⊕ Screwdriver for plain slotted screws, short version 543-IS 60 ⊖ Screwdriver for cross slotted screws, short version 555-PH 1 ⊕	1	900
0000410607000	OMS-36L/37L	empty module	1	80

OMS-7

MODULE-QUATROLIT®-2C-SCREWDRIVERS

- ▶ for ELORA-roller tool cabinets
- ▶ black, with yellow signal colour
- ▶ oil and grease resistant
- ▶ chemical resistant
- ▶ Width: 41,0 cm, Depth: 18,9 cm
- ▶ hard foam insert



Code	Number	Contents	Pieces	Weight/g
0000410701000	OMS-7	QUATROLIT®-2C-Screwdriver for plain slotted screws 539-IS 75, 90, 100, 125, 150 ⊖ QUATROLIT®-2C-Screwdriver for cross slotted screws 559-PH 1, 2, 3 ⊕ Screwdriver for plain slotted screws, short version 543-IS 60 ⊖ Screwdriver for cross slotted screws, short version 555-PH 2 ⊕	1	900
0000410607000	OMS-36L/37L	empty module	1	80

OMS-36

MODULE-QUATROLIT®-2C-SCREWDRIVERS

- ▶ for ELORA-roller tool cabinets
- ▶ black, with yellow signal colour
- ▶ oil and grease resistant
- ▶ chemical resistant
- ▶ Width: 41,0 cm, Depth: 18,9 cm
- ▶ hard foam insert



Code	Number	Contents	Pieces	Weight/g
0000413601000	OMS-36	QUATROLIT®-2C-Screwdriver for plain slotted screws 539-IS 90, 100, 125, 150 ⊖ QUATROLIT®-2C-Screwdriver for plain slotted screws 545-IS 75 QUATROLIT®-2C-Screwdriver for cross slotted screws 569-PZ 1, 2, 3 ⊕ Screwdriver for plain slotted screws, short version 543-IS 60 ⊖ Screwdriver for cross slotted screws, short version 554-PZ 2 ⊕	1	900
0000410607000	OMS-36L/37L	empty module	1	80

OMS-37
MODULE-QUATROLIT®-2C-SCREWDRIVERS

- for ELORA-roller tool cabinets
- black, with yellow signal colour
- oil and grease resistant
- chemical resistant
- Width: 41,0 cm, Depth: 18,9 cm
- hard foam insert



Code	Number	Contents	Pieces	Weight/g
0000413701000	OMS-37	QUATROLIT®-2C-Screwdriver for plain slotted screws 539-IS 75, 90, 100, 125, 150 ⇄ QUATROLIT®-2C-Screwdriver for cross slotted screws 569-PZ 1, 2, 3 ⚙ Screwdriver for plain slotted screws, short version 543-IS 60 ⇄ Screwdriver for cross slotted screws, short version 554-PZ 2 ⚙	1	900
0000410607000	OMS-36L/37L	empty module	1	80

OMS-38
MODULE-QUATROLIT®-2C-SCREWDRIVERS

- for ELORA-roller tool cabinets
- black, with yellow signal colour
- oil and grease resistant
- chemical resistant
- Width: 41,0 cm, Depth: 18,9 cm
- hard foam insert

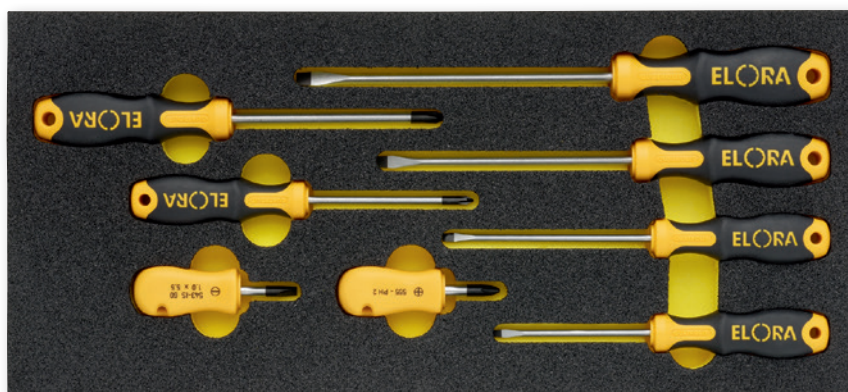

Code	Number	Contents	Pieces	Weight/g
0000413801000	OMS-38	QUATROLIT®-2C-Screwdriver for plain slotted screws 545-IS 75, 100, 125, 150 ⇄ QUATROLIT®-2C-Screwdriver for cross slotted screws 549-PZ 1, 2 ⚙ Screwdriver for plain slotted screws, short version 543-IS 45 ⇄ Screwdriver for cross slotted screws, short version 554-PZ 1 ⚙	1	470
0000411107000	OMS-11/38L	empty module	1	80

OMS-16
MODULE ENGINEER SCREWDRIVERS

- for ELORA-roller tool cabinets
- black, with yellow signal colour
- oil and grease resistant
- chemical resistant
- Width: 41,0 cm, Depth: 18,9 cm
- hard foam insert

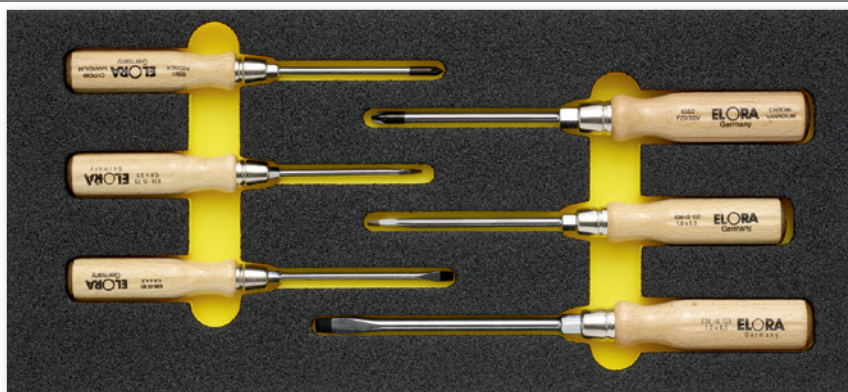
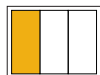

Code	Number	Contents	Pieces	Weight/g
0000411601000	OMS-16	Screwdriver for plain slotted screws with wooden handle ⇄ 636-IS 75, 90, 100, 125 Screwdriver for cross slotted screws with wooden handle ⚙ 658-PZ 1, 2	1	460
0000411607000	OMS-16L	empty module	1	80

OMS-17

MODULE ENGINEER SCREWDRIVERS

- for ELORA-roller tool cabinets
- black, with yellow signal colour
- oil and grease resistant
- chemical resistant
- Width: 41,0 cm, Depth: 18,9 cm
- hard foam insert

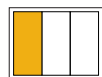
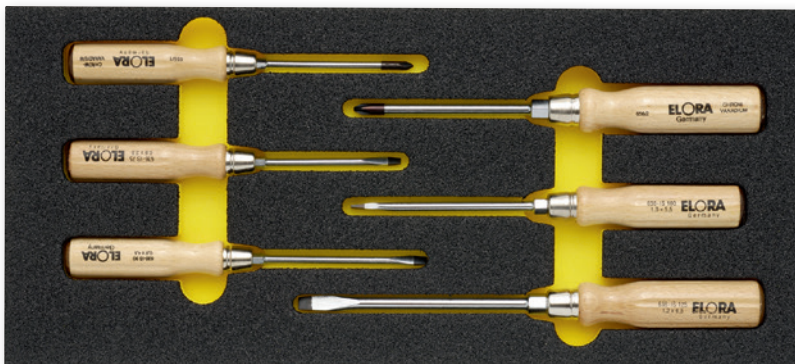

Code	Number	Contents	Pieces	Weight/g
0000411701000	OMS-17	Screwdriver for plain slotted screws with wooden handle 636-IS 75, 90, 100, 125 Screwdriver for cross slotted screws with wooden handle 656-PH 1, 2	1	460
0000411707000	OMS-17L	empty module	1	80

OMS-43

MODULE VDE SCREWDRIVERS

- for ELORA-roller tool cabinets
- black, with yellow signal colour
- oil and grease resistant
- chemical resistant
- Width: 41,0 cm, Depth: 18,9 cm
- hard foam insert

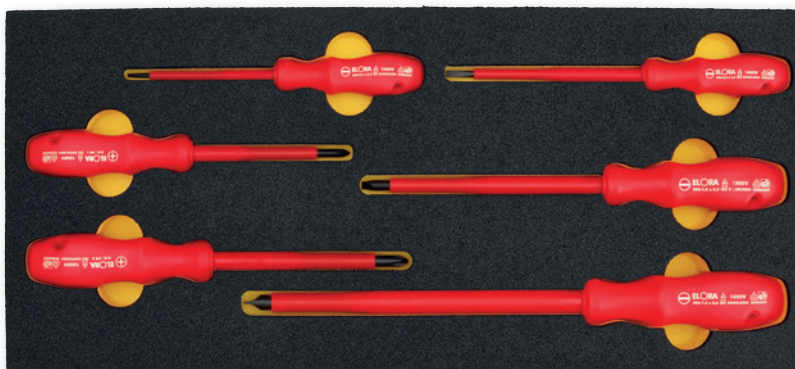

Code	Number	Contents	Pieces	Weight/g
0000414301000	OMS-43	VDE Screwdriver for plain slotted screws 900-IS 75, 106, 12510, 175 VDE Screwdriver for cross slotted screws 910-PH 1, 2	1	460
0000414307000	OMS-43L	empty module	1	80

OMS-10

MODULE-PLIERS

- for ELORA-roller tool cabinets
- black, with yellow signal colour
- oil and grease resistant
- chemical resistant
- Width: 41,0 cm, Depth: 18,9 cm
- hard foam insert

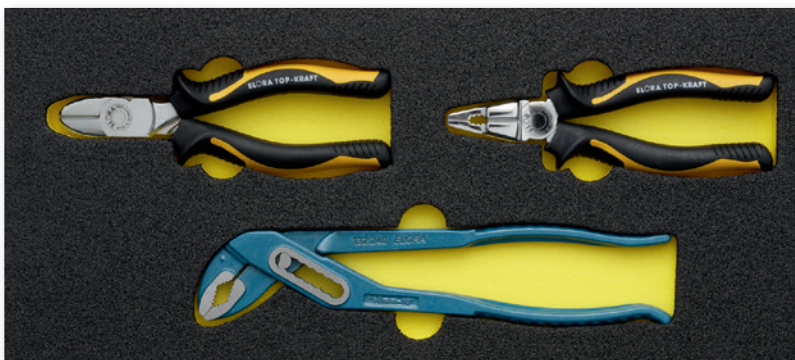

Code	Number	Contents	Pieces	Weight/g
0000411001000	OMS-10	Combination Plier, German pattern 495BI-165 Diagonal Cutter 492BI-160 Waterpump Plier 132-240	1	845
0000411007000	OMS-10L	empty module	1	80

OMS-53
MODULE-PLIERS

- for ELORA-roller tool cabinets
- black, with yellow signal colour
- oil and grease resistant
- chemical resistant
- Width: 41,0 cm, Depth: 57,3 cm
- hard foam insert

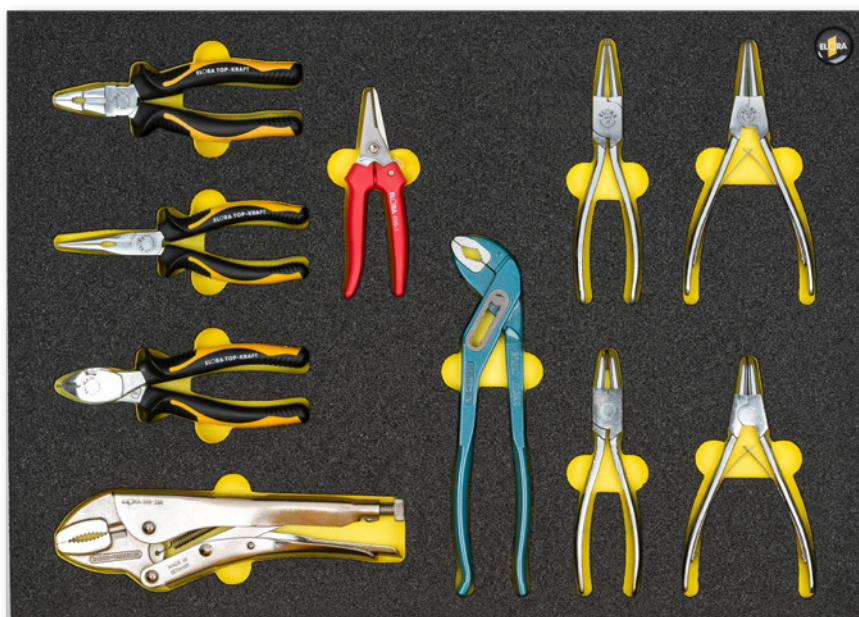

Code	Number	Contents	Pieces	Weight/g
0000415301000	OMS-53	Grip Plier with Wire Cutter, for round and flat material 500-250 Universal Scissors, straight 498-1 Heavy Duty Side Cutter 490BI-165 Snipe Nose Plier with side cutter, straight pattern Form 470BI-165 Combination Plier, German pattern 495BI-165 Waterpump Plier 132-240 Circlip Plier for internal Retaining Ring, straight jaws 473-J2 Circlip Plier for internal Retaining Ring, jaws bent at 90° 473-J21 Circlip Plier for external Retaining Ring, straight jaws 474-A2 Circlip Plier for external Retaining Ring, jaws bent at 90° 474-A21	1	2340
0000415307000	OMS-53L	empty module	1	160

OMS-5
MODULE-PLIERS

- for ELORA-roller tool cabinets
- black, with yellow signal colour
- oil and grease resistant
- chemical resistant
- Width: 41,0 cm, Depth: 18,9 cm
- hard foam insert

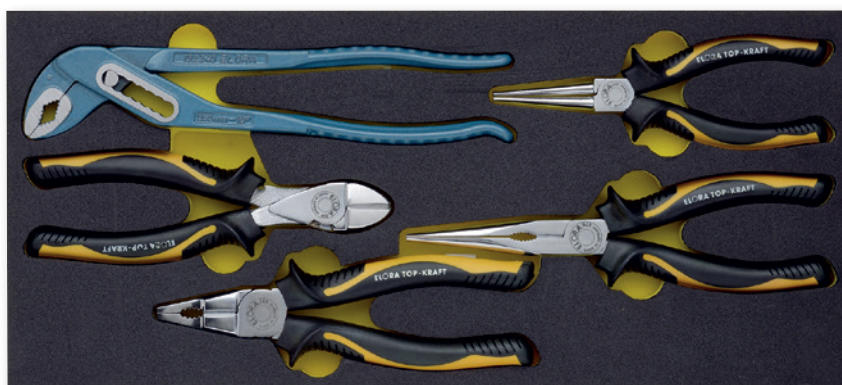

Code	Number	Contents	Pieces	Weight/g
0000410501000	OMS-5	Snipe Nose Plier with side cutter, straight pattern 470BI-200 Round Nose Plier with long jaws 477BI-170 Heavy Duty Side Cutter 490BI-165 Combination Plier, German pattern 495BI-185 Waterpump Plier 132-240	1	1200
0000410507000	OMS-5L	empty module	1	80

OMS-42

MODULE-VDE PLIERS

- for ELORA-roller tool cabinets
- black, with yellow signal colour
- oil and grease resistant
- chemical resistant
- Width: 41,0 cm, Depth: 18,9 cm
- hard foam insert

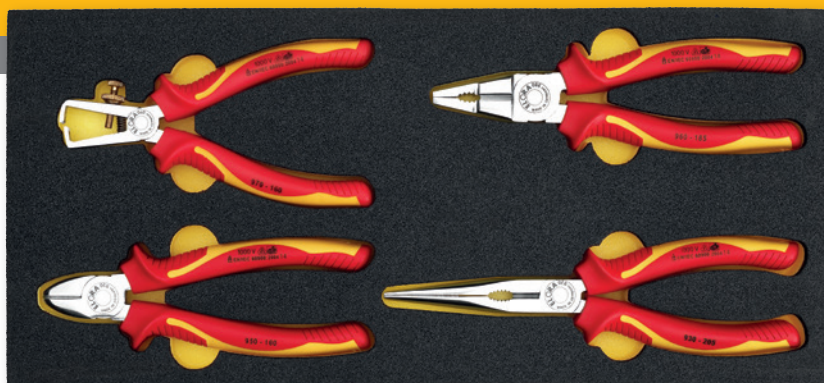
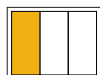

Code	Number	Contents	Pieces	Weight/g
0000414201000	OMS-42	VDE Universal Side Cutter with handle insulation 950-160 VDE Combination Plier with Handle Insulation 960-185 VDE Wire Stripper with Handle Insulation 970-160 VDE Snipe Nose Plier with Handle Insulation 930-205	1	900
0000414207000	OMS-42L	empty module	1	60

OMS-20

MODULE-CIRCLIP PLIER

- for ELORA-roller tool cabinets
- black, with yellow signal colour
- oil and grease resistant
- chemical resistant
- Width: 41,0 cm, Depth: 18,9 cm
- hard foam insert

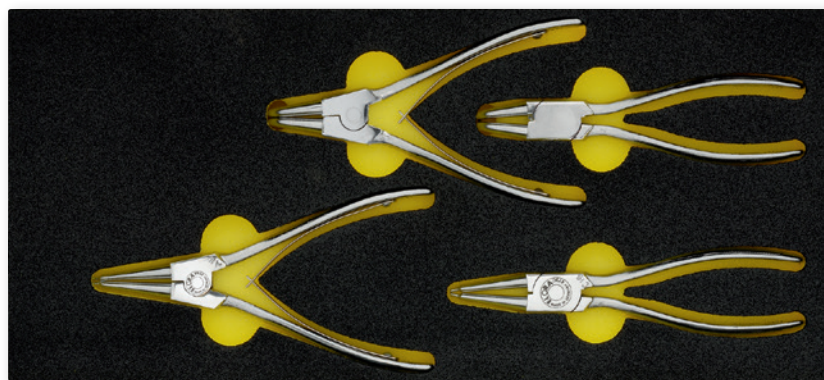
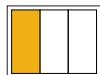

Code	Number	Contents	Pieces	Weight/g
0000412001000	OMS-20	Circlip Plier for internal Retaining Ring, straight jaws 473-J2 Circlip Plier for internal Retaining Ring, jaws bent at 90° 473-J21 Circlip Plier for external Retaining Ring, straight jaws 474-A2 Circlip Plier for external Retaining Ring, jaws bent at 90° 474-A21	1	650
0000412007000	OMS-20L	empty module	1	80

OMS-12

MODULE-HAND STRIKING TOOLS

- for ELORA-roller tool cabinets
- black, with yellow signal colour
- oil and grease resistant
- chemical resistant
- Width: 41,0 cm, Depth: 18,9 cm
- hard foam insert

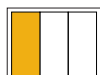

Code	Number	Contents	Pieces	Weight/g
0000411201000	OMS-12	Flat Chisel, flat oval 260-200 Centre Punch 265-10 Parallel Pin Punch 271-2, 3, 4, 5, 6, 8 Engineer's Hammer, German Pattern 1665-500	1	1520
0000411207000	OMS-12L	empty module	1	80

OMS-45
MODULE-FILES AND HAND STRIKING TOOLS

- for ELORA-roller tool cabinets
- black, with yellow signal colour
- oil and grease resistant
- chemical resistant
- Width: 41,0 cm, Depth: 57,3 cm
- hard foam insert

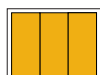

Code	Number	Contents	Pieces	Weight/g
0000414501000	OMS-45	Flat Chisel, flat oval 260-200 Cape Chisel, flat oval 261-200 Centre Punch 265-10 Parallel Pin Punch 271-3, 4, 5, 6, 8 Three Square Hollow Ground Scraper 272-150 Engineers File 208-2x200 Rectangular File 246-2x200 Half Round File 247-2x200	1	4410
0000414507000	OMS-45L	empty module	1	160

OMS-8
MODULE-HAND STRIKING TOOLS

- for ELORA-roller tool cabinets
- black, with yellow signal colour
- oil and grease resistant
- chemical resistant
- Width: 41,0 cm, Depth: 18,9 cm
- hard foam insert



Code	Number	Contents	Pieces	Weight/g
0000410801000	OMS-8	Flat Chisel, flat oval 260-150 Flat Chisel, octagonal 262-150 Cape Chisel, flat oval 261-150	1	2200
0000410807000	OMS-8L	empty module	1	80

OMS-54
MODULE TESTING AND MEASURING TOOLS

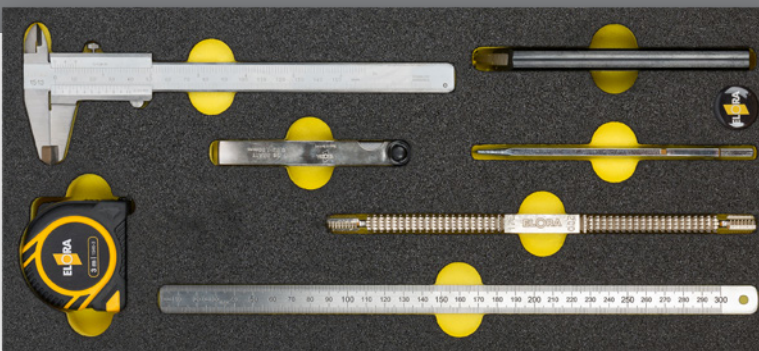
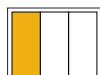

- for ELORA-roller tool cabinets
- black, with yellow signal colour
- oil and grease resistant
- chemical resistant
- Width: 41,0 cm, Depth: 18,9 cm
- hard foam insert



Code	Number	Contents	Pieces	Weight/g
0000415401000	OMS-54	Precision Vernier Caliper 1513 Thread Restoring File 258 MM Carbide Hexagon Engineer's Scriber 1592 Feeler Gauge 188-26M	1	755
0000415407000	OMS-54L	empty module	1	80

WS OMS-5
INDUSTRIAL

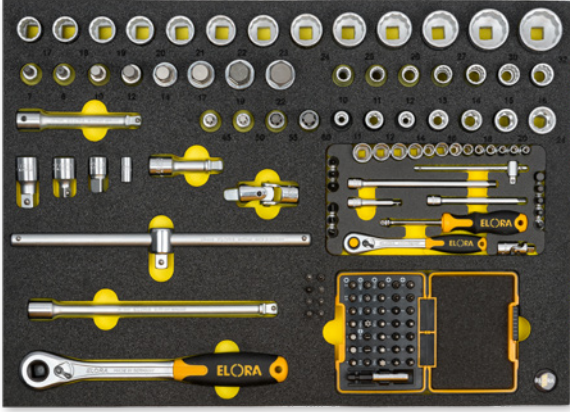
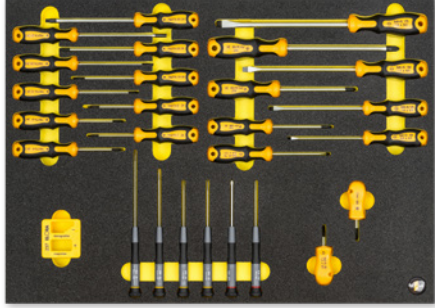
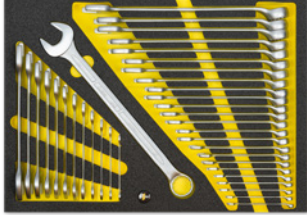
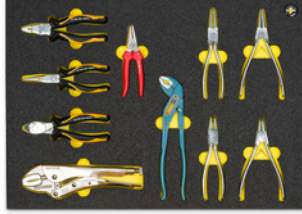
► suitable for Roller Tool Cabinet Buddy ELORA-No. 1210-L7, Super Caddy ELORA-No. 1220-L7 and L8, ToolJET ELORA-No. 1225-L7





Code	Number	Contents	Pieces 	Weight/g
0000501220005	WS OMS-5	217 Tools	1 assortment	22710
OMS-46		 <p>1440-MU Socket Set 1/4", 30 pcs. </p> <p>Bitbox 1/4", 36 pcs. </p> <p>Screwdriver Bit 1/4" for Inside TORX® Screws ✱</p> <p>3050-TX 6, 7, 8, TX 9, TX 10</p> <p>Screwdriver Bit 1/4" for Inside TORX® Safety Screws ✱</p> <p>3070-TTX 10, 15, 27</p> <p>Socket Converter 1/4" 1450-16, 1/4" 1/4" </p> <p>Bihexagon Sockets 1/2" </p> <p>770-LM 10, 11, 12, 13, 14, 15, 16, 17, 18, 19, 20, 21, 22, 23, 24, 25, 26, 27, 30, 32 mm</p> <p>Reversible Ratchet 1/2" 770-L1D</p> <p>Sliding T-Bar 1/2" 770-L3</p> <p>Extension Bar 1/2" 50 mm 770-L35</p> <p>Extension Bar 1/2", swivelling 75 mm 770-L4V</p> <p>Extension Bar 1/2", swivelling 125 mm 770-L5V</p> <p>Extension Bar 1/2", swivelling 250 mm 770-L6V</p> <p>Universal Joint 1/2" 770-L7</p> <p>Socket Converter 1/2" 770-L13, 3/8" 1/2" </p> <p>Socket Converter 1/2" 770-L14, 1/2" 3/8" </p> <p>Screwdriver Sockets 1/2" for inside Hexagon Screws ●</p> <p>3210-IN 7, IN 8, IN 10, IN 12, IN 14, IN 17, IN 19, IN 22</p> <p>Screwdriver Sockets 1/2" for Inside TORX® Screws ✱</p> <p>3245-TX 45, TX 50, TX 55, TX 60</p> <p>Sockets 1/2" for Outside TORX® Screws </p> <p>770-LTXE 11, 12, 14, 16, 18, 20, 24 mm</p>		
123-pcs.				
OMS-48		 <p>QUATROLIT®-2C-Screwdriver for plain slotted screws </p> <p>545-IS 75, 100, 125, 150, 175</p> <p>Screwdriver for plain slotted screws, short version </p> <p>543-IS 60</p> <p>Screwdriver for cross slotted screws, short version </p> <p>555-PH 2</p> <p>QUATROLIT®-2C-Screwdriver for cross slotted screws </p> <p>547-PH 1, 2, 3</p> <p>Electronic Screwdriver for plain slotted screws </p> <p>600-IS 1,5x60, 1,8x60, 2,5x75, 3,0x100</p> <p>Electronic Screwdriver for cross slotted screws </p> <p>610-PH 00, PH 0</p> <p>Screwdriver for Inside TORX® screws ✱</p> <p>760TX-6, 7, 8, 9, 10, 15, 20, 25, 27, 30</p> <p>Magnetizer-Demagnetizer 237</p>		
27-pcs.				
OMS-50		 <p>Combination Spanners, cranked</p> <p>205- 6, 7, 8, 9, 10, 11, 12, 13, 14, 15, 16, 17, 18, 19, 20, 21, 22, 23, 24, 25, 26, 27, 28, 30, 32 mm</p> <p>Double Open-Ended Spanners DIN 3110</p> <p>100- 6x7, 8x9, 10x11, 12x13, 14x15, 16x17, 18x19, 20x22, 21x23, 24x27, 25x28, 30x32 mm</p>		
38-pcs.				
OMS-53		 <p>Grip Plier with Wire Cutter, for round and flat material 500-250</p> <p>Universal Scissors, straight 498-1</p> <p>Heavy Duty Side Cutter 490BI-165</p> <p>Snipe Nose Plier with side cutter, straight pattern Form 470BI-165</p> <p>Combination Plier, German pattern 495BI-165</p> <p>Waterpump Plier 132-240</p> <p>Circlip Plier for internal Retaining Ring, straight jaws 473-J2</p> <p>Circlip Plier for internal Retaining Ring, jaws bent at 90° 473-J21</p> <p>Circlip Plier for external Retaining Ring, straight jaws 474-A2</p> <p>Circlip Plier for external Retaining Ring, jaws bent at 90° 474-A21</p>		
10-pcs.				
OMS-45		 <p>Flat Chisel, flat oval 260-200</p> <p>Cape Chisel, flat oval 261-200</p> <p>Centre Punch 265-10</p> <p>Parallel Pin Punch 271-3, 4, 5, 6, 8</p> <p>Three Square Hollow Ground Scraper 272-150</p> <p>Engineers File 208-2x200</p> <p>Rectangular File 246-2x200</p> <p>Half Round File 247-2x200</p> <p>Round File 248-2x200</p> <p>Cutter 281-P</p> <p>Seal Flat Scraper 290</p> <p>Rubber Mallet 1620-65</p> <p>Engineer's Hammer, German Pattern 1665-300</p> <p>Dead-Blow Nylon Soft Faced Hammer 1690-40</p> <p>Mounting Bar 166</p> <p>Measuring Tape 1546-3</p>		
19-pcs.				

WS OMS-6

AUTOMOTIVE

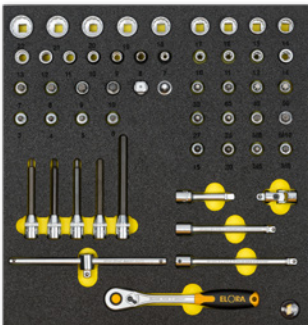
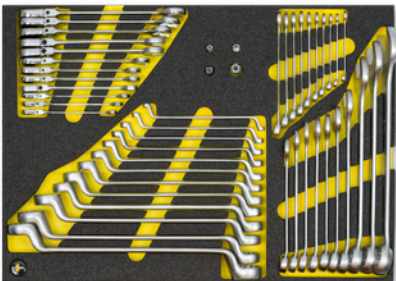
➤ suitable for Roller Tool Cabinet Buddy ELORA-No. 1210-L7, Super Caddy ELORA-No. 1220-L7 and L8, ToolJET ELORA-No. 1225-L7

01

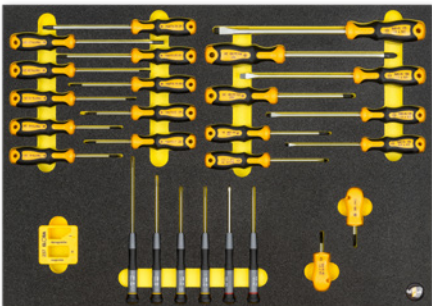
Code	Number	Contents	Pieces	Weight/g
0000501220006	WS OMS-6	177 Tools	1 assortment	25990
OMS-49		<p>Bi-Hexagon Sockets ○ 870- 7, 8, 9, 10, 11, 12, 13, 14, 15, 16, 17, 18, 19, 20, 21, 22 mm Screwdriver Sockets ● 3510-IN 3, 4, 5, 6, 7, 8, 9, 10 Screwdriver Sockets long for inside hexagon screws ● 3510-INL 4x100, 5x100, 6x100, 8x100, 10x130 Screwdriver Sockets for inside-TORX® screws ★ 3244-TX 15, 20, 25, 27, 30, 40, 45, 50 Screwdriver Sockets for inside multi-point B & S and XZN screws ● 3530-XZN 5, 6, 8, 10 Screwdriver Sockets for Outside-TORX® screws ⊕ 870-TXE 10, 11, 12, 14 Reversible Ratchet 870-1D Sliding T-Bar 870-8 Universal Joint 870-9 Extension Bar, swivelling 50 mm 870-3V Extension Bar, swivelling 125 mm 870-35V Extension Bar, swivelling 150 mm 870-4V Socket Converter 870-10, 1/4" ■ 3/8" ○ Socket Converter 770-L14, 1/2" ■ 3/8" ○</p>		
53-pcs.				
OMS-51		<p>Combination Spanners, bent 203- 6, 7, 8, 9, 10, 11, 12, 13, 14, 15, 16, 17, 18, 19, 21, 22, 24, 27, 30, 32, mm Double-Ended Ring Spanners, DIN 838 110- 6x7, 8x9, 10x11, 12x13, 14x15, 16x17, 18x19, 20x22, 21x23, 24x27, 25x28, 30x32 mm Combination Spanner with Joint-Ring Ratchet 204R- 8, 9, 10, 11, 12, 13, 14, 15, 16, 17, 18, 19 mm Adapter Drives for bits 1/4", 3/8", 1/2" und 1/4" Bit-Adaptor 118- 1, 2, 3, 4</p>		
48-pcs.				
OMS-53		<p>Grip Plier with Wire Cutter, for round and flat material 500-250 Universal Scissors, straight 498-1 Heavy Duty Side Cutter 490BI-165 Snipe Nose Plier with side cutter, straight pattern Form 470BI-165 Combination Plier, German pattern 495BI-165 Waterpump Plier 132-240 Circlip Plier for internal Retaining Ring, straight jaws 473-J2 Circlip Plier for internal Retaining Ring, jaws bent at 90° 473-J21 Circlip Plier for external Retaining Ring, straight jaws 474-A2 Circlip Plier for external Retaining Ring, jaws bent at 90° 474-A21</p>		
10-pcs.				
OMS-47		<p>Combination Spanner with Ring Ratchet, reversible 204-J 8, 10, 12, 13, 17, 19 mm ○ Double-Ended Ring Spanner for outside TORX®-Screws 119TXE- 6x8, 10x12, 14x18, 20x24 mm ⊕ Open Ring Spanner 121-10x11 mm ○ Adjustable Wrench 60-12 MB Spark Plug Socket 1/2" ○  771-LTZ 16, 18, 20, 8 mm Socket Converter 770-L14, 1/2" ■ 3/8" ○ Impact Socket 1/2" ○ 790LTP-17, 19, 21 mm Torque Wrench with Vernier Scale 2179-60 10-60 Nm, 2179-200 40-200 Nm Engineer's Hammer, German Pattern 1665-500 Feeler Gauge 188-13 M Tyre Lever 165-300, 165-500 Brush for Brake Service 293 BS Seal Flat Scraper 290-1</p>		
39-pcs.				
OMS-48		<p>QUATROLIT®-2C-Screwdriver for plain slotted screws ⊖ 545-IS 75, 100, 125, 150, 175 Screwdriver for plain slotted screws, short version ⊖ 543-IS 60 Screwdriver for cross slotted screws, short version ⊕ 555-PH 2 QUATROLIT®-2C-Screwdriver for cross slotted screws ⊕ 547-PH 1, 2, 3 Electronic Screwdriver for plain slotted screws ⊖ 600-IS 1,5x60, 1,8x60, 2,5x75, 3,0x100 Electronic Screwdriver for cross slotted screws ⊕ 610-PH 00, PH 0 Screwdriver for Inside TORX® screws ★ 760TX-6, 7, 8, 9, 10, 15, 20, 25, 27, 30 Magnetizer-Demagnetizer 237</p>		
27-pcs.				

MS-2

MODULE-COMBINATION SPANNERS, CRANKED

- black, with transparent cover
- Width: 31,5 cm, Depth: 14,5 cm
- stable ABS plastic



Code	Number	Contents	Pieces	Weight/g
0000502001000	MS-2	Combination Spanners, cranked 205- 8, 10, 11, 13, 14, 17, 19, 22 mm	1	976
0000502007000	MS-2L	empty module	1	140

MS-6

MODULE--COMBINATION SPANNERS, BENT

- black, with transparent cover
- Width: 31,5 cm, Depth: 14,5 cm
- stable ABS plastic



Code	Number	Contents	Pieces	Weight/g
0000506001000	MS-6	Combination Spanners, bent 203-8, 10, 11, 13, 17, 19, 22, 24 mm	1	1028
0000502007000	MS-2L	empty module	1	140

MS-10

MODULE-COMBINATION SPANNER WITH RING RATCHET

- black, with transparent cover
- Width: 31,5 cm, Depth: 14,5 cm
- stable ABS plastic



Code	Number	Contents	Pieces	Weight/g
0000510001000	MS-10	Combination Spanners with Ring Ratchets 204- 8, 9, 10, 12, 13, 14, 17, 19 mm	1	940
0000502007000	MS-2L	empty module	1	140

MS-50
MODULE-SOCKET SET 1/4"

- black, with transparent cover
- Width: 31,5 cm, Depth: 14,5 cm
- stable ABS plastic



6,3

1/4"



Code	Number	Contents	Pieces	Weight/g
0000550001000	MS-50	Screwdriver Sockets for inside hexagon screws ★ 3243-TX 8, 9, 10, 15, 20, 25, 27, 30, 40 Sockets for outside TORX® screws ☼ 1455-TXE 4, 5, 6, 7, 8, 10, 11 Screwdriver Sockets for inside hexagon screws ● 1455-IN 3, 4, 5, 6, 8 mm Hexagon Sockets ○ 4, 4,5, 5, 5,5, 6, 7, 8, 9, 10, 11, 12, 13, 14 mm Reversible Ratchet 1450-1D Spinner Handle 1450-3 Sliding T-Bar 1450-4 Universal Joint 1450-8 Extension Bar 50 mm 1450-11 Extension Bar 100 mm 1450-5 Extension Bar 150 mm 1450-12	1	892
0000550007000	MS-50L	empty module	1	95

MS-11/12
MODULE-SOCKET SET 1/2"

- black, with transparent cover
- Width: 31,5 cm, Depth: 14,5 cm
- stable ABS plastic



12,5

1/2"



Code	Number	Contents	Pieces	Weight/g
0000511001000	MS-11	Bihexagon Sockets ○ 770-LM 10, 11, 12, 13, 14, 15, 16, 17, 18, 19, 20, 22 mm Reversible Ratchet 770-L1D Extension Bar 250 mm 770-L6 Sliding T-Bar 770-L3	1	2140
0000512001000	MS-12	same as MS-11, but all sockets in hexagon pattern ○	1	2140
0000511007000	MS-11L	empty module	1	95

MS-14

MODULE-TORX®-TOOLS

- black, with transparent cover
- Width: 31,5 cm, Depth: 14,5 cm
- stable ABS plastic



12,5

1/2"



Code	Number	Contents	Pieces	Weight/g
0000514001000	MS-14	Screwdriver Sockets for inside TORX® screws ☉ 3245 TX 20, 25, 27, 30, 40, 45, 50, 55, 60 TORX®-Ball End Key Set ☼ 162S-TXKU 9, 10, 15, 20, 25, 27, 30, 40	1	918
0000513007000	MS-13L	empty module	1	95

MS-13

MODULE-ALLEN KEYS SOCKET SET 1/2"

- black, with transparent cover
- Width: 31,5 cm, Depth: 14,5 cm
- stable ABS plastic



12,5

1/2"



mm

Code	Number	Contents	Pieces	Weight/g
0000513001000	MS-13	Screwdriver Socket 1/2" for Inside hexagon screws ● 3210 IN 4, 5, 6, 8, 10, 12, 14, 17, 19 mm Ball End Hexagon Key Set, extra long, 1,5-10 mm 159SKU	1	1486
0000513007000	MS-13L	empty module	1	95

MS-38

MODULE-QUATROLIT® 2C-SCREWDRIVER

- black, with transparent cover
- Width: 31,5 cm, Depth: 14,5 cm
- stable ABS plastic



Code	Number	Contents	Pieces	Weight/g
0000538001000	MS-38	QUATROLIT®-2C-Screwdrivers for plain slotted screws ☉ 545-IS 75, 100, 125, 150 QUATROLIT®-2C-Screwdrivers for cross slotted screws ☼ 547-PH 1, 2	1	455
0000531007000	MS-31L/41L	empty module	1	96

MS-39
MODULE-QUATROLIT® 2C-SCREWDRIVER

- black, with transparent cover
- Width: 31,5 cm, Depth: 14,5 cm
- stable ABS plastic



Code	Number	Contents	Pieces	Weight/g
0000539001000	MS-39	QUATROLIT®-2C-Screwdrivers for plain slotted screws ⊖ 545-IS 75, 100, 125, 150 QUATROLIT®-2C-Screwdrivers for cross slotted screws ⊕ 549-PZ 1, 2	1	456
0000531007000	MS-31L/41L	empty module	1	96

MS-36
MODULE-QUATROLIT® 2C-SCREWDRIVER

- black, with transparent cover
- Width: 31,5 cm, Depth: 14,5 cm
- stable ABS plastic



Code	Number	Contents	Pieces	Weight/g
0000536001000	MS-36	QUATROLIT®-2C-Screwdrivers for plain slotted screws ⊖ 539-IS 75, 100, 125, 150 QUATROLIT®-2C-Screwdrivers for cross slotted screws ⊕ 559-PH 1, 2	1	574
0000531007000	MS-31L/41L	empty module	1	96

MS-37
MODULE-QUATROLIT® 2C-SCREWDRIVER

- black, with transparent cover
- Width: 31,5 cm, Depth: 14,5 cm
- stable ABS plastic



Code	Number	Contents	Pieces	Weight/g
0000537001000	MS-37	QUATROLIT®-2C-Screwdrivers for plain slotted screws ⊖ 539-IS 75, 100, 125, 150 QUATROLIT®-2C-Screwdrivers for cross slotted screws ⊕ 569-PZ 1, 2	1	575
0000531007000	MS-31L/41L	empty module	1	96

MS-40

MODULE-ENGINEER SCREWDRIVER

- black, with transparent cover
- Width: 31,5 cm, Depth: 14,5 cm
- stable ABS plastic



Code	Number	Contents	Pieces	Weight/g
0000540001000	MS-40	Screwdriver for plain slotted screws with wooden handle 636-IS 75, 90, 100, 125 Screwdriver for cross slotted screws with wooden handle 656-PH 1, 2	1	500
0000531007000	MS-31L/41L	empty module	1	96

MS-41

MODULE-ENGINEER SCREWDRIVER

- black, with transparent cover
- Width: 31,5 cm, Depth: 14,5 cm
- stable ABS plastic



Code	Number	Contents	Pieces	Weight/g
0000541001000	MS-41	Screwdriver for plain slotted screws with wooden handle 636-IS 75, 90, 100, 125 Screwdriver for cross slotted screws with wooden handle 658-PZ 1, 2	1	500
0000531007000	MS-31L/41L	empty module	1	96

MS-32

MODUL-VDE-SCREWDRIVER

- black, with transparent cover
- Width: 31,5 cm, Depth: 14,5 cm
- stable ABS plastic



Code	Number	Contents	Pieces	Weight/g
0000532001000	MS-32	VDE-Screwdriver for plain slotted screws 900IS-75, 106, 12510, 175 VDE-Screwdriver for cross slotted screws 910-PH 1, 2	1	518
0000531007000	MS-31L/41L	empty module	1	96

MS-23
MODUL-VDE-PLIERS

- black, with transparent cover
- Width: 31,5 cm, Depth: 14,5 cm
- stable ABS plastic



Code	Number	Contents	Pieces	Weight/g
0000523001000	MS-23	VDE Combination Plier with Handle Insulation 960-185 VDE Snipe Nose Plier with Handle Insulation 930-205 VDE Universal Side Cutter with handle insulation 950-160	1	802
0000521007000	MS-21L	empty module	1	96

MS-21
MODULE-PLIERS

- black, with transparent cover
- Width: 31,5 cm, Depth: 14,5 cm
- stable ABS plastic



Code	Number	Contents	Pieces	Weight/g
0000521001000	MS-21	Combination Plier, German pattern 495BI-185 Snipe Nose Plier with Side Cutter, straight pattern 470BI-200 Heavy Duty Side Cutter 490BI-165	1	806
0000521007000	MS-21L	empty module	1	96

MS-25

MODUL-CIRCLIP PLIER SET

- black, with transparent cover
- Width: 31,5 cm, Depth: 14,5 cm
- stable ABS plastic

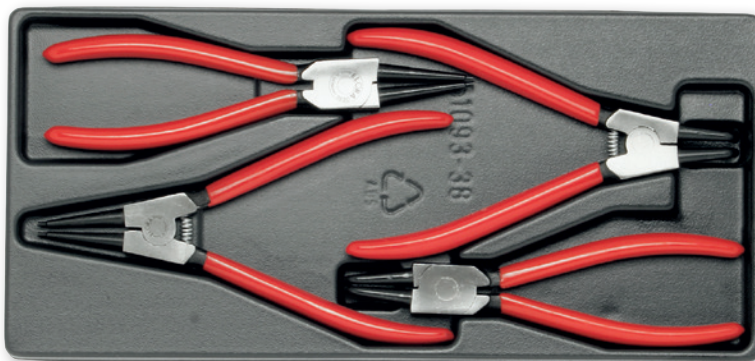

Code	Number	Contents	Pieces	Weight/g
0000525001000	MS-25	Circlip Plier for internal Retaining Ring, straight jaws 383-J2 Circlip Plier for internal Retaining Ring, jaws bent at 90° 383-J21 Circlip Plier for external Retaining Ring, straight jaws 384-A2 Circlip Plier for external Retaining Ring, jaws bent at 90° 384-A21	1	783
0000524007000	MS-25L	empty module	1	96

MS-26

MODUL-CIRCLIP PLIER SET

- black, with transparent cover
- Width: 31,5 cm, Depth: 14,5 cm
- stable ABS plastic

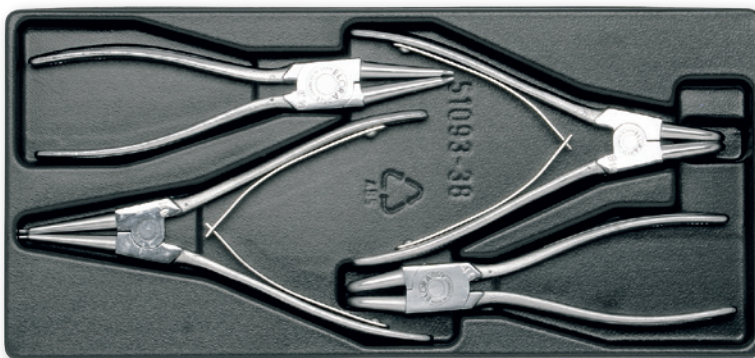

Code	Number	Contents	Pieces	Weight/g
0000526001000	MS-26	Circlip Plier for internal Retaining Ring, straight jaws 473-J2 Circlip Plier for internal Retaining Ring, jaws bent at 90° 473-J21 Circlip Plier for external Retaining Ring, straight jaws 474-A2 Circlip Plier for external Retaining Ring, jaws bent at 90° 474-A21	1	769
0000524007000	MS-25L	empty module	1	96



ELORA

Zielsetzungen der Wandlung: zukunftsfähige Unternehmensstruktur
 Signs of transition: modern corporate appearance

Familienunternehmen in dritter Generation
 Family business in the third generation

Umsatz in die ELORA-Vertriebsfiliale, ein Unternehmen
 Revenue to the sales subsidiary, a company

Unternehmensübergabe an die zweite Generation
 Management in the second generation

Erweiterung der Produktion: neue Werkzeuge
 Expansion of the production plant: new tools

Wachstum des Unternehmens in Deutschland
 Growth of the company in Germany

ELORA als Anbieter für B2- und B2B-Kunden
 ELORA as provider for B2 and B2B customers

Ein Unternehmen, das über 100 Jahre alt ist
 A company that has existed for over 100 years

ELORA-Produktionsstätte in Deutschland
 ELORA production plant in Germany

Ein Unternehmen, das über 100 Jahre alt ist
 A company that has existed for over 100 years

Ein Unternehmen, das über 100 Jahre alt ist
 A company that has existed for over 100 years

NFT

SCHLAGWERKZEUGE
 STRIKING TOOLS

ELORA

ZANGEN, BOLZENSCHNEIDER UND BILDSCHEREN
 PLIERS, BOLT CUTTERS AND SHEARS

ELORA

STECKSCHLÜSSEL UND IMPACT WERKZEUGE
 SOCKET ASSORTMENTS AND IMPACT TOOLS

ELORA

STECKSCHLÜSSEL UND IMPACT WERKZEUGE
 SOCKET ASSORTMENTS AND IMPACT TOOLS

WS-1M

TOOL ASSORTMENT

- suitable for Tool Cabinet ELORA-No. 1100L
- suitable for Roller Tool Cabinet Buddy ELORA-No. 1210-L7, Super Caddy ELORA-No. 1220-L7 and L8, ToolJET ELORA-No. 1225-L7

Code	Number	Contents	Pieces	Weight/g
0000500101000	WS-1M	64 metric tools	1 assortment	8300
205-...	8, 9, 10, 11, 12, 13, 14, 15, 16, 17, 19, 22 mm			
1 pc. each				
770-LM...	10, 11, 12, 13, 14, 15, 16, 17, 19, 22, 24, 27, 30, 32 mm	12,5 1/2"		
1 pc. each				
158R-1	2; 2,5; 3; 4; 5; 6; 8; 10 mm			
1 pc. each				
770-L1D	270 mm	12,5 1/2"		
1 pc. each				
770-L3	300 mm	12,5 1/2"		
1 pc. each				
770-L5/L6	125 mm 250 mm	12,5 1/2"		
1 pc. each				
770-L7	75 mm	12,5 1/2"		
1 pc. each				
539-IS...	100, 125, 150	⊖		
1 pc. each				
545-IS75		⊖		
1 pc. each				
547-PH...	PH1 PH2 PH3	⊕		
1 pc. each				
1665-300				
1 pc. each				
266-K	262-125 mm 262-150 mm 263-125 mm 264-120x10x4 mm 264-120x12x4 mm 265-120x10mm			
1 pc. each				
271-K	271-150x2 mm 271-150x3 mm 271-150x4 mm 271-150x5 mm 271-150x6 mm 271-150x8 mm			
1 pc. each				
132-240				
1 pc. each				
495-BI 165		⊖		
1 pc. each				
246-2x200				
1 pc. each				
247-2x200				
1 pc. each				
248-2x200				
1 pc. each				

WS-1A
TOOL ASSORTMENT

- suitable for Tool Cabinet ELORA-No. 1100L
- suitable for Roller Tool Cabinet Buddy ELORA-No. 1210-L7, Super Caddy ELORA-No. 1220-L7 and L8, ToolJET ELORA-No. 1225-L7

Code	Number	Contents	Pieces	Weight/g
0000600101000	WS-1A	64 inch tools	1 assortment	8300
205-...	5/16, 3/8, 7/16, 1/2, 9/16, 5/8, 11/16, 3/4, 13/16, 7/8, 15/16, 1 AF			
1 pc. each				
770-LM...	3/8, 7/16, 1/2, 9/16, 19/32, 5/8, 11/16, 3/4, 13/16, 7/8, 1, 1.1/16, 1.1/8, 1.1/4 AF			12,5 1/2"
1 pc. each				
158R-3	1/16, 5/64, 3/32, 1/8, 5/32, 3/16, 7/32, 1/4 AF			
1 pc. each				
770-L1D	270 mm			12,5 1/2"
770-L3	300 mm			12,5 1/2"
770-L5/L6	125 mm 250 mm			12,5 1/2"
1 pc. each				
770-L7	75 mm			12,5 1/2"
539-IS...	100, 125, 150			
1 pc. each				
545-IS75				
547-PH...	PH1 PH2 PH3			
1 pc. each				
1665-300				
266-K	262-125 mm 262-150 mm 263-125 mm 264-120x10x4 mm 264-120x12x4 mm 265-120x10mm			
1 pc. each				
271-K	271-150x2 mm 271-150x3 mm 271-150x4 mm 271-150x5 mm 271-150x6 mm 271-150x8 mm			
1 pc. each				
132-240				
495-BI165				
246-2x200				
247-2x200				
248-2x200				

WS-2M

TOOL ASSORTMENT

- suitable for tool cabinet ELORA-No. 1100L
- suitable for Roller Tool Cabinet Buddy ELORA-No. 1210-L7, Super Caddy ELORA-No. 1220-L7 and L8, ToolJET ELORA-No. 1225-L7
- suitable for cantilever tool box ELORA-Nr. 810-L

Code	Number	Contents	Pieces	Weight/g
0000500201000	WS-2M	90 metric tools	1 assortment	15000
100-...	6x7, 8x9, 10x11, 12x13, 14x15, 16x17, 18x19, 20x22, 24x27, 30x32 mm			
1 pc. each				
110-...	6x7, 8x9, 10x11, 12x13, 14x15, 16x17, 18x19, 20x22, 24x27, 30x32 mm			
1 pc. each				
770-LM...	10, 11, 12, 13, 14, 15, 16, 17, 18, 19, 21, 22, 24, 27, 30, 32 mm			12,5 1/2"
1 pc. each				
157-S11M	4, 4,5, 5, 5,5, 6, 6,5, 7, 7,5 mm			
1 pc. each				
158-R1	2; 2,5; 3; 4; 5; 6; 8; 10 mm			
1 pc. each				
188-13M	0,05, 0,10, 0,15, 0,20, 0,25, 0,30, 0,40, 0,50, 0,60, 0,70, 0,80, 0,90, 1,00			
770-L1D	270 mm			12,5 1/2"
770-L3	300 mm			12,5 1/2"
770-L5/L6	125 mm 250 mm			12,5 1/2"
1 pc. each				
770-L7	75 mm			12,5 1/2"
222-16x20,8				
545-IS...	75, 100, 125, 150, 200			
547-PH...	PH1 PH2 PH3			
1 pcs. each				
246-2x200				
247-2x200				
248-2x200				
132-240				
500-250				
1665-500				
470-BI 200				
490-BI 165				
495-BI 185				
1660-32				
251-45				
60-8A				
242KM-250	250 ml			
165-500	2 pcs.			
189				
1542-3				
249 S6				
250-4				
266-K	262-125 mm 262-150 mm 263-125 mm 264-120x10x4 mm 264-120x12x4 mm 265-120x10mm			
1 pc. each				

WS-2A
TOOL ASSORTMENT

- suitable for tool cabinet ELORA-No. 1100L
- suitable for Roller Tool Cabinet Buddy ELORA-No. 1210-L7, Super Caddy ELORA-No. 1220-L7 and L8, ToolJET ELORA-No. 1225-L7
- suitable for cantilever tool box ELORA-Nr. 810-L

Code	Number	Contents	Pieces	Weight/g
0000600201000	WS-2A	89 inch tools	1 assortment	14500
100A-...	1/4x5/16, 5/16x3/8, 3/8 x7/16, 7/16x1/2, 1/2x9/16, 9/16x5/8, 5/8x11/16, 11/16x3/4, 3/4x7/8, 13/16x7/8, 15/16x1, 1.1/16x1.1/4 AF			
1 pc. each				
110A-...	1/4x5/16, 3/8x7/16, 1/2x9/16, 5/8x11/16, 3/4x25/32, 13/16x7/8, 15/16x1, 1.1/16x1.1/4 AF			
1 pc. each				
770-LA...	3/8, 7/16, 1/2, 9/16, 19/32, 5/8, 11/16, 3/4, 13/16, 25/32, 7/8, 15/16, 1, 1.1/8, 1.1/4 AF			12,5 1/2"
1 pc. each				
157-S11AF	3/16, 7/32, 1/4, 9/32, 5/16, 11/32, 3/8 AF			
1 pc. each				
158-R3	1/16, 5/64, 3/32, 1/8, 5/32, 3/16, 7/32, 1/4 AF			
1 pc. each				
188-13Z	.002, .003, .004, .005, .006, .008, .010, .012, .015, .020, .025, .030, 035			
770-L1D	270 mm			12,5 1/2"
770-L3	300 mm			12,5 1/2"
770-L5/L6	125 mm 250 mm			12,5 1/2"
1 pc. each				
770-L7	75 mm			12,5 1/2"
222-16x20,8				
545-IS...	75, 100, 125, 150, 200			
547-PH...	PH1 PH2 PH3			
1 pc. each				
246-2x200				
247-2x200				
248-2x200				
132-240				
500-250				
1665-500				
470-BI200				
490-BI 165				
495-BI 185				
1660-32				
251-45				
60-8A				
242KM-250	250 ml			
165-500	2 pcs.			
189				
1542-3				
249 S6				
250-4				
266-K	262-125 mm 262-150 mm 263-125 mm 264-120x10x4 mm 264-120x12x4 mm 265-120x10mm			
1 pc. each				

WS-3M

TOOL ASSORTMENT

- suitable for tool cabinet ELORA-No. 1100L
- suitable for Roller Tool Cabinet Buddy ELORA-No. 1210-L7, Super Caddy ELORA-No. 1220-L7 and L8, ToolJET ELORA-No. 1225-L7
- suitable for cantilever tool box ELORA-Nr. 810-L

Code	Number	Contents	Pieces	Weight/g
0000500301000	WS-3M	80 metric tools	1 assortment	17500
100-...	6x7, 8x9, 10x11, 12x13, 14x15, 16x17, 18x19, 20x22, 21x23, 24x27, 25x28, 30x32 mm			
1 pc. each				
110-...	6x7, 8x9, 10x11, 12x13, 14x15, 16x17, 18x19, 20x22, 21x23, 24x27, 25x28, 30x32 mm			
1 pc. each				
205-...	8, 9, 10, 11, 13, 17, 19, 22 mm			
1 pc. each				
770-LM...	10, 11, 12, 13, 14, 15, 16, 17, 18, 19, 20, 21, 22, 23, 24, 25, 26, 27, 30, 32 mm			12,5 1/2"
1 pc. each				
770-L1D	270 mm			12,5 1/2"
770-L3	300 mm			12,5 1/2"
770-L5/L6	125 mm 250 mm			12,5 1/2"
1 pc. each				
770-L7	75 mm			12,5 1/2"
222-16x20,8				
165-500	2 pcs.			
60-8A				
60-10A				
132-240				
470-BI 200				
490-BI 165				
495-BI 185				
473-J2				IN
473-J21				IN
539-IS...	100, 125, 150, 200		1 pc. each	
545-IS...	75, 150		1 pc. each	
547-PH...	PH1 PH2		1 pc. each	
260-150				
261-150				
265-10				
264-...	264-120x10x2 mm 264-120x10x3 mm 264-120x12x4 mm 264-120x12x5 mm 264-120x12x6 mm		1 pc. each	
1665-500				
246-2x200				
247-2x200				
248-2x200				
189				

WS-3A
TOOL ASSORTMENT

- suitable for tool cabinet ELORA-No. 1100L
- suitable for Roller Tool Cabinet Buddy ELORA-No. 1210-L7, Super Caddy ELORA-No. 1220-L7 and L8, ToolJET ELORA-No. 1225-L7
- suitable for cantilever tool box ELORA-Nr. 810-L

Code	Number	Contents	Pieces	Weight/g
0000600301000	WS-3A	79 inch tools	1 assortment	17300
100A-...	1/4x5/16, 5/16x3/8, 3/8 x7/16, 7/16x1/2, 1/2x9/16, 9/16x5/8, 5/8x11/16, 11/16x3/4, 3/4x7/8, 13/16x7/8, 15/16x1, 1.1/16x1.1/4 AF			
1 pc. each				
110A-...	1/4x5/16, 5/16x3/8, 3/8x7/16, 7/16x1/2, 1/2x9/16, 9/16x5/8, 5/8x11/16, 3/4x25/32, 13/16x7/8, 15/16x1, 1x1.1/8, 1.1/16x1.1/4 AF			
1 pc. each				
205A-...	5/16, 3/8, 7/16, 1/2, 9/16, 5/8, 11/16, 3/4 AF			
1 pc. each				
770-LA...	3/8, 7/16, 1/2, 9/16, 19/32, 5/8, 11/16, 3/4, 25/32, 13/16, 7/8, 15/16, 31/32, 1, 1.1/16, 1.1/8, 1.3/16, 1.1/4 AF			 12,5 1/2"
1 pc. each				
770-L1D	270 mm			12,5 1/2"
770-L3	300 mm			12,5 1/2"
770-L5/L6	125 mm 250 mm			12,5 1/2"
1 pc. each				
770-L7	75 mm			12,5 1/2"
222-16x20,8				
165-500	2 pcs.			
60-8A				
60-10A				
132-240				
470-BI 200				
490-BI 165				
495-BI 185				
473-J2				
473-J21				
539-IS...	100, 125, 150, 200		1 pc. each	
545-IS...	75, 150		1 pc. each	
547-PH...	PH1 PH2		1 pc. each	
260-150				
261-150				
265-10				
264-...	264-120x10x2 mm 264-120x10x3 mm 264-120x12x4 mm 264-120x12x5 mm 264-120x12x6 mm		1 pc. each	
1665-500				
246-2x200				
247-2x200				
248-2x200				
189				

WS-4M

TOOL ASSORTMENT "MECHATRONIC"

- suitable for tool cabinet ELORA-No. 1100L
- suitable for Roller Tool Cabinet Buddy ELORA-No. 1210-L7, Super Caddy ELORA-No. 1220-L7 and L8, ToolJET ELORA-No. 1225-L7
- suitable for cantilever tool box ELORA-Nr. 810-L
- suitable for hard protective case ELORA-No. 1380-L and hard protective trolley case ELORA-No. 1381-L

Code	Number	Contents	Pieces	Weight/g
0000500401101	WS-4M	131 metric tools	1 assortment	22800
205-...	6, 7, 8, 9, 10, 11, 12, 13, 14, 15, 16, 17, 18, 19, 20, 21, 22 mm			
1 pc. each				
1455-M...	4, 4.5, 5, 5.5, 6, 7, 8, 9, 10, 11, 13 mm			
1 pc. each		6,3 1/4"		
770-LM...	10, 11, 12, 13, 14, 15, 16, 17, 19, 22, 24, 27, 30, 32 mm			
1 pc. each		12,5 1/2"		
159-...	1,5, 2, 2,5, 3, 4, 5, 6, 8, 10, 12 mm			
1 pc. each				
1450-1D	145 mm		6,3 1/4"	
1450-4	270 mm		6,3 1/4"	
1450-5	100 mm		6,3 1/4"	
1450-8	45 mm		6,3 1/4"	
1450-3	150 mm		6,3 1/4"	
1450-16	25 mm		6,3 1/4"	
770-L1D	270 mm		12,5 1/2"	
770-L3	300 mm		12,5 1/2"	
770-L5/L6	125 mm 250 mm		12,5 1/2"	
1 pc. each				
770-L7	75 mm		12,5 1/2"	
1080				
1513				
1591				
1543-3				
242KM-125	125 ml			
466A-16,0				
930-205				
960-185				
950-160				
900IS-...	108, 12508			
1 pc. each				
910PH-...	PH1 PH2			
1 pc. each				
564N				
561				
600-IS...	1,2 x 60, 1,5 x 60 2,0 x 60			
610-PH...	00 x 60 0 x 60			
4680-MH E				
4550-F E				
262-150				
265-10				
271-...	3,0, 5,0			
1 pc. each				
246-2x200				
207-2x200				
248-2x200				
189				
1665-500				
1690-30				
3436-S36	Bit-Box 36 pcs.			

WS-4A
TOOL ASSORTMENT "MECHATRONIC"

- suitable for tool cabinet ELORA-No. 1100L
- suitable for Roller Tool Cabinet Buddy ELORA-No. 1210-L7, Super Caddy ELORA-No. 1220-L7 and L8, ToolJET ELORA-No. 1225-L7
- suitable for cantilever tool box ELORA-Nr. 810-L
- suitable for hard protective case ELORA-No. 1380-L and hard protective trolley case ELORA-No. 1381-L

Code	Number	Contents	Pieces	Weight/g
0000600401101	WS-4A	128 inch tools	1 assortment	22800
205A-...	1/4, 5/16, 3/8, 7/16, 1/2, 9/16, 19/32, 5/8, 11/16, 3/4, 13/16, 7/8, 15/16, 1, 1.1/16, 1.1/4 AF			
1 pc. each				
1455-A...	3/16, 7/32, 1/4, 9/32, 5/16, 11/32, 3/8, 7/16, 1/2 AF			
1 pc. each		6,3 1/4"		
770-LM...	3/8, 7/16, 1/2, 9/16, 19/32, 5/8, 11/16, 3/4, 13/16, 7/8, 1, 1.1/16, 1.1/8, 1.1/4 AF			
1 pc. each		12,5 1/2"		
159A-...	1/16, 5/64, 3/32, 1/8, 5/32, 3/16, 7/32, 1/4, 5/16, 3/8 AF			
1 pc. each				
1450-1D	145 mm			
		6,3 1/4"		
1450-4	270 mm			
		6,3 1/4"		
1450-5	100 mm			
		6,3 1/4"		
1450-8	45 mm			
		6,3 1/4"		
1450-3	150 mm			
		6,3 1/4"		
1450-16	25 mm			
		6,3 1/4"		
770-L1D	270 mm			
		12,5 1/2"		
770-L3	300 mm			
		12,5 1/2"		
770-L5/L6	125 mm 250 mm			
1 pc. each		12,5 1/2"		
770-L7	75 mm			
		12,5 1/2"		
1080				
1513				
1591				
1543-3				
242KM-125	125 ml			
466A-16,0				
930-205				
960-185				
950-160				
900IS-...	108, 12508			
1 pc. each				
910PH-...	PH1 PH2			
1 pc. each				
564N				
561				
600-IS...	1,2 x 60, 1,5 x 60 2,0 x 60			
610-PH...	00 x 60 0 x 60			
4680-MH E				
4550-F E				
262-150				
265-10				
271-...	3,0, 5,0			
1 pc. each				
246-2x200				
207-2x200				
248-2x200				
189				
1665-500				
1690-30				
3436-S36	Bit-Box 36 pcs.			

WS-5M

TOOL ASSORTMENT

- suitable for tool cabinet ELORA-No. 1100L
- suitable for Roller Tool Cabinet Buddy ELORA-No. 1210-L7, Super Caddy ELORA-No. 1220-L7 and L8, ToolJET ELORA-No. 1225-L7

Code	Number	Contents	Pieces	Weight/g
0000500501100	WS-5M	146 metric tools	1 assortment	28600
100-...	6x7; 8x9; 10x11; 12x13; 14x15; 16x17; 18x19; 20x22; 21x23; 24x27; 25x28; 30x32 mm			
1 pc. each				
110-...	6x7; 8x9; 10x11; 12x13; 14x15; 16x17; 18x19; 20x22; 21x23; 24x27; 25x28; 30x32 mm			
1 pc. each				
205-...	8; 9; 10; 11; 12; 13; 14; 15; 16; 17; 18; 19; 20; 21; 22 mm			
1 pc. each				
770-LM...	10; 11; 12; 13; 14; 15; 16; 17; 18; 19; 21; 22; 23; 24; 25; 26; 27; 30; 32 mm		12,5	1/2"
1 pc. each				
1455-M...	4; 4,5; 5; 5,5; 6; 7; 8; 9; 10; 11; 13 mm		6,3	1/4"
1 pcs. each				
157-11M	4; 4,5; 5; 5,5; 6; 6,5; 7; 7,5 mm			
1 pc. each				
158R-1	2; 2,5; 3; 4; 5; 6; 8; 10 mm			
1 pc. each				
188-13M	0,05; 0,10; 0,15; 0,20; 0,25; 0,30; 0,40; 0,50; 0,60; 0,70; 0,80; 0,90; 1,00			
1 pc. each				
770-L1D	270 mm		12,5	1/2"
770-L2	300 mm		12,5	1/2"
770-L3	300 mm		12,5	1/2"
770-L5/L6	125 mm 250 mm		12,5	1/2"
1 pc. each				
770-L7	75 mm		12,5	1/2"
1450-1D	145 mm		6,3	1/4"
1450-3	150 mm		6,3	1/4"
1450-4	270 mm		6,3	1/4"
1450-5	100 mm		6,3	1/4"
1450-8	270 mm		6,3	1/4"
222-16x20,8	16x20,8 mm			
165-500	500 mm			
2 pcs.				
170-...	170-24x27 mm 170-32x38 mm			
171-500x18	500 mm			
195CV-17	17; 19; 22 mm; 11/16"AF			
60-...	60-6A, 160mm / 6"; 60-8A, 210mm / 8"; 60-10A, 260mm / 10"			
1 pc. each				
480-330	330 mm			
132-...	132-190 mm, 132-240 mm			
500-250	250 mm			
470-BI 200	200 mm			
471-45BI 200	200 mm			
485-BI 165	165 mm			
490-BI 165	165 mm			
495-BI 185	185 mm			
473-J2	180 mm			
473-J21	165 mm			
474-...	A2 A21			
1 pc. each				
242KM-250	250 ccm			
539-IS...	IS 100; 150			
1 pc. each				
545-IS...	IS 75; 100; 150			
1 pc. each				
543-IS 60				
555-PH1				
547-PH...	547-PH 1; PH 2			
1 pc. each				
260	260-150 mm; 260-200 mm			
1 pc. each				
261-150	150 mm			
264-...	264-120x10x3; 120x12x4 ; 120x12x5; 120x12x6 mm			
1 pc. each				
265-10	120x10 mm			
189	420 mm			
1665-300	300 g			
1665-35				
266-K	262-125 mm, 262-150 mm 263-125 mm, 264-120x10x4 mm 264-120x12x4 mm, 265-120x10mm			
246-1x200	200 mm/8"			
247-2x200	200 mm/8"			
248-2x200	200 mm/8"			
352-S6	screw extractor set 350-6; 8; 11; 14; 18; 24			
1 set				

WS-5A

TOOL ASSORTMENT

- suitable for tool cabinet ELORA-No. 1100L
- suitable for Roller Tool Cabinet Buddy ELORA-No. 1210-L7, Super Caddy ELORA-No. 1220-L7 and L8, ToolJET ELORA-No. 1225-L7

Code	Number	Contents	Pieces	Weight/g
0000600501100	WS-5A	151 inch tools	1 assortment	28200
100A-...	1/4x5/16; 5/16x3/8; 3/8 x7/16; 7/16x1/2; 1/2x9/16; 9/16x5/8; 5/8x11/16; 11/16x3/4; 3/4x7/8; 13/16x7/8; 15/16x1; 1.1/16x1.1/4 AF			
1 pc. each				
110A-...	1/4x5/16; 5/16x3/8; 3/8x7/16; 7/16x1/2; 1/2x9/16; 9/16x5/8; 5/8x11/16; 3/4x25/32; 13/16x7/8; 15/16x1; 1x1.1/8; 1.1/16x1.1/4 AF			
1 pc. each				
205A-...	5/16; 3/8; 7/16; 1/2; 9/16; 9/32; 5/8; 11/16; 3/4; 1/4; 13/16; 7/8; 15/16; 1; 1.1/16; 1.1/8; 1.1/4 AF			
1 pc. each				
770-LA...	3/8; 7/16; 1/2; 9/16; 19/32; 5/8; 11/16; 3/4; 25/32; 13/16; 7/8; 15/16; 31/32; 1; 1.1/16; 1.1/8; 1.3/16; 1.1/4 AF		12,5	1/2"
1 pc. each				
1455-A...	3/16; 7/32; 1/4; 9/32; 5/16; 11/32; 3/8; 7/16; 1/2 AF		6,3	1/4"
1 pc. each				
157-11A	3/16; 7/32; 1/4; 9/32; 5/16; 11/32; 3/8; 7/16 AF			
1 pc. each				
158R-3	1/16; 5/64; 3/32; 1/8; 5/32; 3/16; 7/32; 1/4 AF			
1 pc. each				
188-13Z	.002; .003; .004; .005; .006; .008; .010; .012; .015; .020; .025; .030; 035			
1 pc. each				
770-L1D	270 mm		12,5	1/2"
770-L2	300 mm		12,5	1/2"
770-L3	300 mm		12,5	1/2"
770-L5/L6	125 mm 250 mm		12,5	1/2"
1 pc. each				
770-L7	75 mm		12,5	1/2"
1450-1D	145 mm		6,3	1/4"
1450-3	150 mm		6,3	1/4"
1450-4	270 mm		6,3	1/4"
1450-5	100 mm		6,3	1/4"
1450-8	270 mm		6,3	1/4"
222-16x20,8	16x20,8 mm			
165-500	500 mm			
2 pcs.				
170-...	170-24x27 mm 170-32x38 mm			
171-500x18	500 mm			
195CV-17	17; 19; 22 mm; 11/16" AF			
60-...	60-6A, 160mm / 6"; 60-8A, 210mm / 8"; 60-10A, 260mm / 10"			
1 pc. each				
480-330	330 mm			
132-...	132-190 mm, 132-240 mm			
500-250	250 mm			
470-BI 200	200 mm			
471-45-BI 200	200 mm			
485-BI 165	165 mm			
490-BI 165	165 mm			
495-BI 185	185 mm			
473-J2	180 mm			
473-J21	165 mm			
474-...	A2 A21			
1 pc. each				
242KM-250	250 ccm			
539-IS...	IS 100; 150			
1 pc. each				
545-IS...	IS 75; 100; 150			
1 pc. each				
543-IS 60				
555-PH1				
547-PH...	547-PH 1; PH 2			
1 pc. each				
260	260-150 mm; 260-200 mm			
1 pc. each				
261-150	150 mm			
264-...	264-120x10x3; 120x12x4 ; 120x12x5; 120x12x6 mm			
1 pc. each				
265-10	120x10 mm			
189	420 mm			
1665-300	300 g			
1665-35				
266-K	262-125 mm, 262-150 mm 263-125 mm, 264-120x10x4 mm 264-120x12x4 mm, 265-120x10mm			
246-1x200	200 mm/8"			
247-2x200	200 mm/8"			
248-2x200	200 mm/8"			
352-S6	screw extractor set 350-6; 8; 11; 14; 18; 24			
1 set				

WS-6M

TOOL ASSORTMENT

- suitable for tool cabinet ELORA-No. 1100L
- suitable for Roller Tool Cabinet Buddy ELORA-No. 1210-L7, Super Caddy ELORA-No. 1220-L7 and L8, ToolJET ELORA-No. 1225-L7
- suitable for cantilever tool box ELORA-Nr. 810-L
- suitable for hard protective case ELORA-No. 1380-L and hard protective trolley Case ELORA-No. 1381-L
- suitable for installation tool bag ELORA-No. 1385-L

Code	Number	Contents	Pieces	Weight/g
0000500601000	WS-6M	85 metric tools	1 assortment	7800
146-...	4, 4,5, 5, 5,5, 6, 7, 8, 9, 10, 11, 12, 13, 14, 17 mm			
1 pc. each				
113-...	4x4,5, 5x5,5, 6x7, 8x9, 10x11 mm			
1 pc. each				
1455-M...	4, 4,5, 5, 5,5, 6, 7, 8, 9, 10, 11, 12, 13, 14 mm	6,3 1/4"		
1 pc. each				
158-R1	2; 2,5; 3; 4; 5; 6; 8; 10 mm			
1 pc. each				
216-...	4, 4,5, 5, 5,5, 6, 7, 8, 9, 10 mm			
1 pc. each				
1450-1D	145 mm	6,3 1/4"		
1450-3	150 mm	6,3 1/4"		
1450-4	270 mm	6,3 1/4"		
1450-5	100 mm	6,3 1/4"		
1450-8	45 mm	6,3 1/4"		
131BI-240				
476-BI...	145 170			
1 pc. each				
477-BI...	145 170			
1 pc. each				
490-BI 165				
494-BI 160				
495-BI 165				
900IS-...	75, 100, 7506, 108, 12510	GS DVE 1000 V		
1 pc. each				
910PH-...	PH0 PH1 PH2	GS DVE 1000 V		
1 pc. each				
242K-60	60 ml			
237-500				
1665-100				
566-150		GS DVE 1000 V		
1591-250				
257A				
740-...	4,0 5,5 8,0	GS DVE 1000 V		
1 pc. each				
730-...	1 + 3	GS DVE 1000 V		
1 pc. each				
271-...	2, 3, 4, 5			
1 pc. each				

WS-9M
TOOL ASSORTMENT

- suitable for tool cabinet ELORA-No. 1100L
- suitable for Roller Tool Cabinet Buddy ELORA-No. 1210-L7, Super Caddy ELORA-No. 1220-L7 and L8, ToolJET ELORA-No. 1225-L7
- suitable for cantilever tool box ELORA-Nr. 810-L
- suitable for hard protective case ELORA-No. 1380-L and hard protective trolley Case ELORA-No. 1381-L
- suitable for Installation tool bag ELORA-No. 1385-L
- suitable for cantilever tool box ELORA-Nr. 800-L, 810-L, 803-L, 813-L

Code	Number	Contents	Pieces	Weight/g
0000500901000	WS-9M	48 metric tools	1 assortment	5300
203-...	6, 7, 8, 10, 13, 15, 17, 19 mm			
1 pc. each				
159-S-KK-1	2,5, 3, 4, 5, 6, 8 mm			
1 pc. each				
770-LM...	10, 11, 12, 13, 14, 15, 16, 17, 18, 19, 20, 22			
1 pc. each		12,5 1/2"		
251				
561				
586				
132-240				
1665-200				
260-150				
265-10				
271-4				
321-180				
470-BI200				
490-BI 165				
495-BI 185				
545-IS...	75, 100, 125, 150			
1 pc. each				
547-...	PH1 PH2			
1 pc. each				
770-L1D	270 mm			
			12,5 1/2"	
770-L3	300 mm			
			12,5 1/2"	
770-L6	250 mm			
			12,5 1/2"	
771-LTZ 20,8				
			12,5 1/2"	

WS-8M

PLUMBING TOOL SET

01

- suitable for tool cabinet ELORA-No. 1100L
- suitable for Roller Tool Cabinet Buddy ELORA-No. 1210-L7, Super Caddy ELORA-No. 1220-L7 and L8, ToolJET ELORA-No. 1225-L7
- suitable for cantilever tool Box ELORA-Nr. 810-L
- suitable for hard protective case ELORA-No. 1380-L and hard protective trolley case ELORA-No. 1381-L
- suitable for cantilever tool box ELORA-Nr. 810-L

Code	Number	Contents	Pieces	Weight/g
0000500811001	WS-8M	59 metric tools	1 assortment	15000
121-...	8x10, 9x11, 12x14, 13x15, 14x16, 17x19, 21x23, 22x24 mm			
1 pc. each				
204-...	10, 11, 12, 13, 14, 15, 16, 17, 18, 19, 22, 24 mm			
1 pc. each				
159-...	1,5, 2, 2,5, 3, 4, 5, 6, 8, 10, 12 mm			
770-L1ZI	250 mm	12,5 1/2"		
539-IS...	100, 125, 150			
1 pc. each				
559-PH...	PH1 PH2			
1 pc. each				
468-BI				
470-BI 165				
60-12MB				
68SN-1.1/2				
132-240				
301-250				
181				
138				
137				
1665-500				
65-2				
179-16				
180-35				
64				
182-42				
365-200x8x10				
362-250				
283HS				
1544H				
561				
189P				
281-90				
1672-1250				
484R-260				
139-100				

WS-8A
PLUMBING TOOL SET

- suitable for tool cabinet ELORA-No. 1100L
- suitable for Roller Tool Cabinet Buddy ELORA-No. 1210-L7, Super Caddy ELORA-No. 1220-L7 and L8, ToolJET ELORA-No. 1225-L7
- suitable for cantilever tool Box ELORA-Nr. 810-L
- suitable for hard protective case ELORA-No. 1380-L and hard protective trolley case ELORA-No. 1381-L
- suitable for cantilever tool box ELORA-Nr. 810-L

Code	Number	Contents	Pieces	Weight/g
0000600811001	WS-8A	57 inch tools	1 assortment	15000
121-...	5/16x3/8, 7/16x1/2, 9/16x5/8, 5/8x3/4, 3/4x7/8, 1x1.1/8 AF			
1 pc. each				
204A-...	5/16, 3/8, 7/16, 1/2, 9/16, 5/8, 11/16, 3/4, 13/16, 7/8, 15/16, 1 AF			
1 pc. each				
159A-...	1/16, 5/64, 3/32, 1/8, 5/32, 3/16, 7/32, 1/4, 5/16, 3/8 AF			
770-L1ZI	250 mm	12,5 1/2"		
539-IS...	100, 125, 150			
1 pc. each				
559-PH...	PH1 PH2			
1 pc. each				
468-BI				
470-BI 165				
60-12MB				
68SN-1.1/2				
132-240				
301-250				
181				
138				
137				
1665-500				
65-2				
179-16				
180-35				
64				
182-42				
365-200x8x10				
362-250				
283HS				
1544H				
561				
189P				
281-90				
1672-1250				
484R-260				
139-100				

WS-10M

ELECTRICIAN TOOL SET

- suitable for tool cabinet ELORA-No. 1100L
- suitable for Roller Tool Cabinet Buddy ELORA-No. 1210-L7, Super Caddy ELORA-No. 1220-L7 and L8, ToolJET ELORA-No. 1225-L7
- suitable for cantilever tool box ELORA-Nr. 810-L
- suitable for hard protective case ELORA-No. 1380-L and hard protective trolley case ELORA-No. 1381-L
- suitable for installation tool bag ELORA-No. 1385-L
- suitable for cantilever tool box ELORA-Nr. 810-L

Code	Number	Contents	Pieces	Weight/g
0000501101001	WS-10M	75 metric tools	1 assortment	5800
100-...	14x17, 18x19, 21x23, 22x24			
1 pc. each				
146-...	4, 4,5, 5, 5,5, 6, 7, 8, 9, 10, 11, 12, 13 mm			
1 pc. each				
159-...	1,5, 2, 2,5, 3, 4, 5, 6, 8, 10, 12 mm			
1 pc. each				
1455-M...	4, 4,5, 5, 5,5, 6, 7, 8, 9, 10, 11, 13 mm			
1 pc. each			6,3	1/4"
1450-1D	145 mm			
			6,3	1/4"
1450-4	270 mm			
			6,3	1/4"
1450-5	100 mm			
			6,3	1/4"
1450-8	45 mm			
			6,3	1/4"
1450-3	150 mm			
			6,3	1/4"
543-IS 60				
555-PH1				
549-PZ...	PZ1, PZ2			
1 pc. each				
730-1				
740-...	5,5, 8,0			
1 pc. each				
910PH-...	PH1, PH2			
1 pc. each				
900IS-...	106, 108, 12508, 150			
1 pc. each				
563				
960-185				
930-165				
920-165				
935-45				
970-160				
61-MB 10				
260-175				
264-...	264-120x10x2 mm, 264-120x10x4 mm			
1 pc. each				
265-10				
365-250x10x15				
1665-300				
132-240				
257-50				
257-S	saw blade, universal			
746				
1591-250				
281				
1546-3				
498-1				

WS-10A
ELECTRICIAN TOOL SET

- suitable for tool cabinet ELORA-No. 1100L
- suitable for Roller Tool Cabinet Buddy ELORA-No. 1210-L7, Super Caddy ELORA-No. 1220-L7 and L8, ToolJET ELORA-No. 1225-L7
- suitable for cantilever tool box ELORA-Nr. 810-L
- suitable for hard protective case ELORA-No. 1380-L and hard protective trolley case ELORA-No. 1381-L
- suitable for installation tool bag ELORA-No. 1385-L
- suitable for cantilever tool box ELORA-Nr. 810-L

Code	Number	Contents	Pieces	Weight/g
0000601101001	WS-10A	75 inch tools	1 assortment	5800
100A-...	9/16x5/8, 11/16x3/4, 13/16x7/8, 15/16x1 AF			
1 pc. each				
146A-...	5/32, 3/16, 7/32, 9/32, 5/16, 11/32, 3/8, 15/32, 7/16, 1/2, 9/16, 5/8 AF			
1 pc. each				
159A-...	1/16, 5/64, 3/32, 1/8, 5/32, 3/16, 7/32, 1/4, 5/16, 3/8 AF			
1 pc. each				
1455-A...	3/16, 7/32, 1/4, 9/32, 5/16, 11/32, 3/8, 7/16, 1/2 AF			
1 pc. each				
1450-1D	145 mm			
1450-4	270 mm			
1450-5	100 mm			
1450-8	45 mm			
1450-3	150 mm			
543-IS 60				
555-PH1				
549-PZ...	PZ1, PZ2			
1 pc. each				
730-1				
740-...	5,5, 8,0			
1 pc. each				
910PH-...	PH1, PH2			
1 pc. each				
900IS-...	106, 108, 12508, 150			
1 pc. each				
563				
960-185				
930-165				
920-165				
935-45				
970-160				
61-MB 10				
260-175				
264-...	264-120x10x2 mm, 264-120x10x4 mm			
1 pc. each				
265-10				
365-250x10x15				
1665-300				
132-240				
257-50				
257-S	saw blade, universal			
746				
1591-250				
281				
1546-3				
498-1				



SPANNERS

Combination spanners _____	Page 72
Open ended spanners _____	Page 87
Hook and DIN spanners _____	Page 94
Ring- and double ended ring spanners _____	Page 98
Slogging and construction _____	Page 110
ring spanners	
Hexagon tubular box spanners _____	Page 115



Up to 10,000 spanners are produced in-house every day by two of our blacksmiths. Who drink 10 litres of water as they work. Day by day.

To make sure each customer gets a perfect ELORA spanner, a complex manufacturing process that has been optimised over the years by highly skilled specialists is required. Below, we illustrate the main production steps in a clear overview.

One key feature of spanners made by ELORA is their excellent rigidity and resistance to bending. Thanks to a finely tuned materials selection process, tried-and-tested manufacturing techniques and tight quality controls, ELORA spanners are well able to withstand the rigours of daily use.

The ergonomically designed shape ensures a firm grip for efficient, safe work. As well as offering a dazzle-free finish, the highgrade matt chrome plating provides longterm protection against corrosion. Our other product characteristics are equally impressive.



Every ELORA spanner contains the collective skills, knowledge and experience of several generations of work in tool manufacture – a fact that is worth every cent and gives the end user the security that he or she has made a worthwhile investment in the future. This means you can look forward to highest-grade quality tools that will work perfectly for years and look great at the same time.

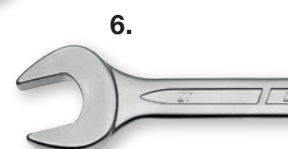

ELO-DRIVE PROFILE

Ring side with a wavy profile

Ring spanners, open-jaw spanners and double-ended ring spanners all feature the ELO-DRIVE profile.

For you as a customer, this means:

- High force transmission to the flats of the fastener without damaging the head
- Efficient, safe working



1. Blanking

The starting material is high-grade ELORA chrome vanadium 31 CrV3/1.2208. The cropped blank for the spanner is cut from the rough blank.
The characteristic shape is recognisable even at this early stage.

2. Hot forging & flash removal

- a. The cropped blank is heated in a furnace to the correct forging temperature and then drop forged in this hot state using high press forces.
- b. Following this, the flash is then removed using flash-removal presses.

3. Hole punching

In the next step, the hole at the ring-end of the spanner is punched.

4. Grinding & vibro-deburring

The subsequent grinding process ensures the tool has a smooth outside surface.
Any sharp edges and flash still remaining are then removed by vibro-deburring.

5. Ring and jaw broaching

The purpose of the broaching operation is to ensure the ring and jaw ends have exactly the right dimensions.

6. Profile punching

The individual marking that identifies our spanners around the world is added during the profile punching operation.

7. Hardening and tempering

This special heat treatment ensures our spanners enjoy the longest possible service lifetimes. The tool's tensile strength is provided by precise hardening and the high level of ductility by the tempering process.

8. Sand blasting & head polishing

To make sure the spanner has a matt, non-slip surface, we sand-blast it. The jaw-end is then also polished to give it a smooth finish.

9. Chrome-plating

Finally, the spanner is nickel-plated and chrome-plated in an electroplating process. The final product now boasts effective surface protection and a specially high-grade appearance. Typically ELORA.



7.

8.

9.



205-..., 205A-..., 205W-...

COMBINATION SPANNER

- long version, both ends fit same nut size
- cranked
- size 5 mm: ring side in hexagon
- up to 34 mm, 1.1/4" AF, 3/4" WW:
jaw polished, shaft matt chrome plated,
all further sizes matt chrome plated
- ELORA-Chrome-Vanadium 31CrV3 / 1.2208
- according to DIN 3113, Form B, ISO 3318, ISO 7738

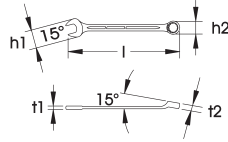

02



Code	Number	l/mm	h1 (max.) mm	h2 (max.) mm	t1 (max.) mm	t2 (max.) mm	Pieces	Weight/g
0205000051000	205-5	123	16,5	10,0	4,4	6	12	20
02050000551001	205-5,5	123	16,5	10,0	4,4	6	12	20
0205000061000	205-6	127	18,0	11,0	4,4	6,9	12	20
0205000071000	205-7	127	18,0	12,5	4,4	6,9	12	22
0205000081000	205-8	139	20,5	14,0	4,7	7,5	12	30
0205000091000	205-9	144	22,5	15,5	4,7	8,1	12	40
0205000101000	205-10	149	24,0	16,5	5,2	8,5	12	40
0205000111000	205-11	162	27,0	18,5	5,3	9,3	12	60
0205000121000	205-12	170	29,0	19,5	5,4	9,8	6	75
0205000131000	205-13	177	30,0	21,0	5,8	10,2	6	75
0205000141000	205-14	194	33,0	22,5	6,3	10,9	6	88
0205000151000	205-15	214	35,5	25,5	6,7	11,7	6	120
0205000161000	205-16	214	35,5	25,5	6,7	11,7	6	120
0205000171000	205-17	234	39,0	27,0	7,2	12,7	6	150
0205000181000	205-18	245	41,0	28,5	7,6	13,3	6	160
0205000191000	205-19	256	41,0	30,0	7,6	13,3	6	190
0205000201000	205-20	274	45,0	33,0	8,0	14,2	6	220
0205000211000	205-21	274	45,0	33,0	8,0	14,2	6	220
0205000221000	205-22	295	48,0	34,5	8,4	15,0	6	290
0205000231000	205-23	319	51,0	37,0	9,0	15,9	3	325
0205000241000	205-24	319	51,0	37,0	9,0	15,9	3	325
0205000251000	205-25	344	55,0	39,0	9,7	17,0	3	390
0205000261000	205-26	344	55,0	39,0	9,7	17,0	3	390
0205000271000	205-27	369	60,0	43,0	10,4	18,5	3	510
0205000281000	205-28	369	60,0	43,0	10,4	18,5	3	510
0205000291000	205-29	394	64,0	45,0	11,2	19,6	3	605
0205000301000	205-30	394	64,0	45,0	11,2	19,6	3	605
0205000321000	205-32	419	69,0	48,0	11,7	20,7	3	770
0205000331000	205-33	419	69,0	48,0	11,7	20,7	3	770
0205000341000	205-34	419	69,0	48,0	11,7	20,7	3	770
0205000361000	205-36	459	77,0	55,0	12,7	22,9	3	950
0205000381000	205-38 / 1.1/2	459	77,0	55,0	12,7	22,9	3	950
0205000411000	205-41 / 1.5/8	509	86,0	61,0	13,7	24,9	3	1350
0205000461000	205-46 / 1.13/16	521	93,0	66,0	14,7	25,8	1	1750
0205000501000	205-50	560	104,0	74,0	16,7	26,6	1	2225
0205000551000	205-55	570	112,0	82,0	19,6	29,0	1	2640
0205000601000	205-60	660	122,0	88,0	21,0	32,0	1	3700
0205000651000	205-65	710	130,0	97,0	23,0	34,0	1	4600
0205000701000	205-70	760	142,0	104,0	25,0	36,0	1	5600
0205000751000	205-75	810	150,0	110,0	27,0	40,0	1	6600
0205000801000	205-80	855	160,0	116,0	30,0	45,0	1	8900



Code	Number	l/mm	h1 (max.) mm
0205100131000	205A-1/4	127	18,5
0205100171000	205A-5/16	139	20,5
0205100181000	205A-11/32	144	22,5
0205100191000	205A-3/8	149	24,0
0205100211000	205A-7/16	162	27,0
0205100231000	205A-1/2	177	30,0
0205100241000	205A-9/16	194	33,0
0205100251000	205A-19/32	214	35,5
0205100261000	205A-5/8	214	35,5
0205100271000	205A-11/16	234	39,0
0205100281000	205A-3/4	256	41,0
0205100301000	205A-13/16	274	45,0
0205100311000	205A-7/8	295	48,0
0205100321000	205A-15/16	319	51,0
0205100341000	205A-1	344	55,0
0205100351000	205A-1.1/16	369	60,0
0205100361000	205A-1.1/8	369	60,0
0205100371000	205A-1.3/16	394	64,0
0205100381000	205A-1.1/4	419	69,0
0205100391000	205A-1.5/16	419	69,0
0205100401000	205A-1.3/8	459	77,0
0205100411000	205A-1.7/16	459	77,0
0205000381000	205-38 / 1.1/2	459	77,0
0205000411000	205-41 / 1.5/8	509	86,0
0205100451000	205A-1.11/16	509	86,0
0205100461000	205A-1.3/4	521	93,0
0205000461000	205-46 / 1.13/16	521	93,0
0205100481000	205A-1.7/8	521	93,0
0205100491000	205A-2	560	104,0
0205100501000	205A-2.1/16	560	104,0
0205100511000	205A-2.1/8	570	112,0
0205100521000	205A-2.3/16	570	112,0
0205100531000	205A-2.1/4	570	112,0
0205100551000	205A-2.3/8	660	122,0
0205100571000	205A-2.1/2	710	130,0
0205100581000	205A-2.9/16	710	130,0
0205100601000	205A-2.3/4	760	142,0
0205100631000	205A-3	810	150,0
0205100651000	205A-3.1/4	855	160,0



	h2 (max.) mm	t1 (max.) mm	t2 (max.) mm	Pieces ☞	Weight/g ⚖	Code	Number	l/mm ┆	h1 (max.) mm	h2 (max.) mm	t1 (max.) mm	t2 (max.) mm	Pieces ☞	Weight/g ⚖
	11,4	4,4	6,9	12	20	0205200061000	205W-1/8	144	22,5	15,5	4,7	8,1	12	40
	14,0	4,7	7,5	12	30	0205200091000	205W-3/16	162	27,0	18,5	5,3	9,3	12	60
	15,5	4,7	8,1	12	40	0205200131000	205W-1/4	177	30,0	21,0	5,8	10,2	6	72
	16,5	5,2	8,5	12	40	0205200171000	205W-5/16	214	35,5	25,5	6,7	11,7	6	120
	18,5	5,3	9,3	12	60	0205200191000	205W-3/8	245	41,0	28,5	7,6	13,3	6	175
	21,0	5,8	10,2	6	72	0205200211000	205W-7/16	274	45,0	33,0	8,0	14,2	6	220
	22,5	6,3	10,9	6	88	0205200231000	205W-1/2	319	51,0	37,0	9,0	15,9	3	325
	25,5	6,7	11,7	6	120	0205200241000	205W-9/16	344	55,0	39,0	9,7	17,0	3	390
	25,5	6,7	11,7	6	120	0205200261000	205W-5/8	369	60,0	43,0	10,4	18,5	3	510
	27,0	7,2	12,7	6	150	0205200271000	205W-11/16	394	64,0	45,0	11,2	19,6	3	605
	30,0	7,6	13,3	6	175	0205200281000	205W-3/4	419	69,0	48,0	11,7	20,7	3	770
	33,0	8,0	14,2	6	220	0205200311000	205W-7/8	459	77,0	55,0	12,7	22,9	3	950
	34,5	8,4	15,0	6	290	0205200321000	205W-15/16	509	86,0	61,0	13,7	24,9	3	1350
	37,0	9,0	15,9	3	325	0205200341000	205W-1	509	86,0	61,0	13,7	24,9	3	1340
	39,0	9,7	17,0	3	390									
	43,0	10,4	18,5	3	510									
	43,0	10,4	18,5	3	510									
	45,0	11,2	19,6	3	605									
	48,0	11,7	20,7	3	770									
	48,0	11,7	20,7	3	770									
	55,0	12,7	22,9	3	950									
	55,0	12,7	22,9	3	950									
	55,0	12,7	22,9	3	950									
	61,0	13,7	24,9	3	1350									
	61,0	13,7	24,9	3	1340									
	66,0	14,7	25,8	1	1750									
	66,0	14,7	25,8	1	1750									
	66,0	14,7	25,8	1	1750									
	74,0	16,7	26,6	1	2200									
	74,0	16,7	26,6	1	2200									
	82,0	19,6	29,0	1	2900									
	82,0	19,6	29,0	1	2900									
	82,0	19,6	29,0	1	2900									
	88,0	21,0	32,0	1	3900									
	97,0	23,0	34,0	1	4700									
	97,0	23,0	34,0	1	4700									
	104,0	25,0	36,0	1	5600									
	110,0	27,0	40,0	1	6600									
	116,0	30,0	45,0	1	7500									

205S...M, 205S...AF, 205S...W

COMBINATION SPANNER SET

- carton box packed
- long version, both ends fit same nut size
- cranked
- jaw polished, shaft matt chrome plated
- ELORA-Chrome-Vanadium 31CrV3 / 1.2208
- according to DIN 3113, Form B, ISO 3318, ISO 7738



02

mm

AF''

Code	Number	Contents	Pieces	Weight/g
0205500801000	205S 8M	205- 8, 10, 11, 13, 14, 17, 19, 22 mm	1	902
0205501001000	205S 10M	205- 6, 7, 8, 9, 10, 11, 13, 14, 17, 19 mm	1	775
0205501201000	205S 12M	205- 6, 7, 8, 9, 10, 11, 13, 14, 16, 17, 19, 22 mm	1	1093
0205501201002	205S 12M-1	205- 10, 11, 12, 13, 14, 17, 19, 22, 24, 27, 30, 32 mm	1	3178
0205501601000	205S 16M	205- 6, 7, 8, 9, 10, 11, 12, 13, 14, 17, 19, 22, 24, 27, 30, 32 mm	1	3240
0205501701000	205S 17M	205- 6, 7, 8, 9, 10, 11, 12, 13, 14, 15, 16, 17, 18, 19, 20, 21, 22 mm	1	1900
0205501801000	205S 18M	205- 8, 9, 10, 11, 12, 13, 14, 16, 17, 18, 19, 21, 22, 24, 27, 30, 32, 34 mm	1	4400
0205502501000	205S 25M	205- 6, 7, 8, 9, 10, 11, 12, 13, 14, 15, 16, 17, 18, 19, 20, 21, 22, 23, 24, 25, 26, 27, 28, 30, 32 mm	1	5715
0205502601000	205S 26M	205- 6, 7, 8, 9, 10, 11, 12, 13, 14, 15, 16, 17, 18, 19, 20, 21, 22, 23, 24, 25, 26, 27, 28, 29, 30, 32 mm	1	6320

Code	Number	Contents	Pieces	Weight/g
0205600801000	205S 8AF	205A- 5/16, 3/8, 7/16, 1/2, 9/16, 5/8, 11/16, 3/4 AF	1	764
0205600801002	205S 8AF-1	205A- 3/8, 7/16, 1/2, 9/16, 5/8, 3/4, 7/8", 1 AF	1	1235
0205601101000	205S 11AF	205A- 1/4, 5/16, 3/8, 7/16, 1/2, 9/16, 5/8, 11/16, 3/4, 13/16, 7/8 AF	1	1300
0205601201000	205S 12AF	205A- 5/16, 3/8, 7/16, 1/2, 9/16, 5/8, 11/16, 3/4, 13/16, 7/8, 15/16, 1 AF	1	1980
0205601601000	205S 16AF	205A- 1/4, 5/16, 3/8, 7/16, 1/2, 9/16, 19/32, 5/8, 11/16, 3/4, 13/16, 7/8, 15/16, 1, 1.1/16, 1.1/4 AF	1	3360

WW

Code	Number	Contents	Pieces	Weight/g
0205800601000	205S 6W	205W- 3/16, 1/4, 5/16, 3/8, 7/16, 1/2 WW	1	982
0205800801000	205S 8W	205W- 3/16, 1/4, 5/16, 3/8, 7/16, 1/2, 5/8, 3/4 WW	1	2265
0205801101000	205S 11W	205W- 1/8, 3/16, 1/4, 5/16, 3/8, 7/16, 1/2, 9/16, 5/8, 11/16, 3/4 WW	1	3300

205S...MSB, 205S...AFSB

COMBINATION SPANNER SET

- in plastic rolling pouch
- with suspension eye
- long version, both ends fit same nut size
- cranked
- jaw polished, shaft matt chrome plated
- ELORA-Chrome-Vanadium 31CrV3 / 1.2208
- according to DIN 3113, Form B, ISO 3318, ISO 7738



mm

AF''

Code	Number	Contents	Pieces	Weight/g
0205500801500	205S 8MSB	205- 8, 10, 11, 13, 14, 17, 19, 22 mm	1	992
0205501201500	205S 12MSB	205- 6, 7, 8, 9, 10, 11, 13, 14, 16, 17, 19, 22 mm	1	1186

Code	Number	Contents	Pieces	Weight/g
0205600801500	205S 8AFSB	205A- 5/16, 3/8, 7/16, 1/2, 9/16, 5/8, 11/16, 3/4 AF	1	822
0205601201500	205S 12AFSB	205A- 1/4, 5/16, 3/8, 7/16, 1/2, 9/16, 19/32, 5/8, 11/16, 3/4, 13/16, 7/8 AF	1	1573

205S...MT, 205S...AFT

COMBINATION SPANNER SET

- in Tetoron rolling pouch
- with suspension eye
- long version, both ends fit same nut size
- cranked
- jaw polished, shaft matt chrome plated
- ELORA-Chrome-Vanadium 31CrV3 / 1.2208
- according to DIN 3113, Form B, ISO 3318, ISO 7738



ELORA DRIVE PROFIL



02



Code	Number	Contents	Pieces	Weight/g	Code	Number	Contents	Pieces	Weight/g
0205500801005	205S 8MT	205- 8, 10, 11, 13, 14, 17, 19, 22 mm	1	1118	0205600801005	205S 8AFT	205A- 5/16, 3/8, 7/16, 1/2, 9/16, 5/8, 11/16, 3/4 AF	1	810
0205501201005	205S 12MT	205- 6, 7, 8, 9, 10, 11, 13, 14, 16, 17, 19, 22 mm	1	1373	0205601601005	205S 16AFT	205A- 1/4, 5/16, 3/8, 7/16, 1/2, 9/16, 19/32, 5/8, 11/16, 3/4, 13/16, 7/8, 15/16, 1, 1.1/16, 1.1/4 AF	1	3410
0205501601005	205S 16MT	205- 6, 7, 8, 9, 10, 11, 12, 13, 14, 17, 19, 22, 24, 27, 30, 32 mm	1	3680					
0205501701005	205S 17MT	205- 6, 7, 8, 9, 10, 11, 12, 13, 14, 15, 16, 17, 18, 19, 20, 21, 22 mm	1	2225					
0205501801005	205S 18MT	205- 8, 9, 10, 11, 12, 13, 14, 16, 17, 18, 19, 21, 22, 24, 27, 30, 32, 34 mm	1	4835					
0205502601005	205S 26MT	205- 6, 7, 8, 9, 10, 11, 12, 13, 14, 15, 16, 17, 18, 19, 20, 21, 22, 23, 24, 25, 26, 27, 28, 29, 30, 32 mm	1	7002					

205-KH9

COMBINATION SPANNER SET

- in black plastic holder
- long version, both ends fit same nut size
- cranked
- jaw polished, shaft matt chrome plated
- ELORA-Chrome-Vanadium 31CrV3 / 1.2208
- according to DIN 3113, Form B, ISO 3318, ISO 7738

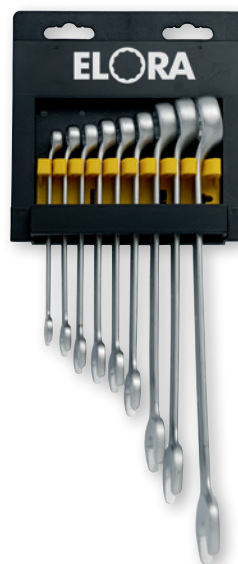

ELORA DRIVE PROFIL



Code	Number	Contents	Pieces	Weight/g
0205500902000	205-KH 9	205- 8, 10, 11, 12, 13, 14, 17, 19, 22 mm	1	1129

You will find the matching OMS-1 module on page no. 26



You will find the matching MS-8 module on page no. 44



200-...

COMBINATION SPANNER, STAINLESS

- to operate rustless bolted connections
- long version, both ends fit same nut size
- cranked
- no galvanic surface treatment
- ELORA-Stainless Steel X20CR13 / 1.4021
- according to DIN 3113, Form B, ISO 3318, ISO 7738

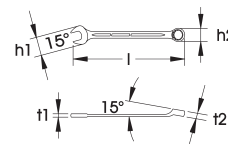

Code	Number	l/mm	h1 mm	h2 mm	t1 mm	t2 mm	Pieces	Weight/g
0200000080000	200-8	139	21,4	14,2	5,3	7,5	12	30
0200000100000	200-10	149	24,5	17,0	5,8	8,5	12	39
0200000110000	200-11	162	27,7	18,7	6,0	9,3	12	56
0200000130000	200-13	177	30,6	21,3	6,6	10,2	6	68
0200000140000	200-14	194	33,5	22,7	7,0	10,9	6	94
0200000170000	200-17	234	39,5	27,2	7,9	12,7	6	142
0200000190000	200-19	256	41,9	30,1	8,3	13,3	6	168
0200000220000	200-22	295	48,7	34,9	9,3	15,0	6	272
0200000240000	200-24	319	51,7	37,1	9,8	15,9	3	325
0200000300000	200-30	394	64,8	45,9	12,1	19,6	3	605
0200000320000	200-32	419	69,3	48,9	12,7	20,7	3	770

MS-8

COMBINATION SPANNER SET, STAINLESS

- in plastic box
- to operate rustless bolted connections
- long version, both ends fit same nut size
- cranked
- no galvanic surface treatment
- ELORA-Stainless Steel X20CR13 / 1.4021
- DIN 3113, Form B / ISO 3318
- according to DIN 3113, Form B, ISO 3318, ISO 7738



Code	Number	Contents	Pieces	Weight/g
0000507001000	MS-8	200- 8, 10, 11, 13, 14, 17, 19, 22 mm	1	1338

203-..., 203A...

COMBINATION SPANNER

- short version,
both ends fit same nut size
- bent
- matt chrome plated
- ELORA-Chrome-Vanadium
31CrV3 / 1.2208
- according to DIN 3113,
Form A, ISO 3318, ISO 7738

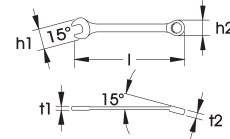
Code	Number	l/mm	h1 mm	h2 mm	t1 mm	t2 mm	Pieces	Weight/g
0203000061000	203-6	103	16,0	11,0	4,0	6,0	12	15
0203000071000	203-7	108	16,0	12,5	4,0	6,0	12	15
0203000081000	203-8	112	18,5	14,0	4,2	7,0	12	22
0203000091000	203-9	124	20,5	16,0	4,2	7,0	12	26
0203000101000	203-10	132	21,5	16,5	4,7	7,4	12	33
0203000111000	203-11	142	23,5	18,0	5,3	7,9	12	40
0203000121000	203-12	155	26,0	19,5	5,4	8,4	12	56
0203000131000	203-13	162	28,0	20,5	5,8	8,4	12	57
0203000141000	203-14	172	30,0	22,5	5,9	9,3	12	70
0203000151000	203-15	187	30,5	23,5	6,2	9,3	12	70
0203000161000	203-16	196	34,0	25,5	6,3	10,3	6	90
0203000171000	203-17	208	34,0	26,5	6,3	10,3	6	90
0203000181000	203-18	220	38,0	28,5	6,7	11,3	6	130
0203000191000	203-19	226	40,0	29,5	7,4	11,3	6	130
0203000201000	203-20	230	41,0	31,5	7,6	12,3	6	175
0203000211000	203-21	230	41,0	31,5	7,6	12,3	6	170
0203000221000	203-22	246	46,0	34,0	8,4	12,3	6	170
0203000231000	203-23	270	49,0	36,0	8,6	13,3	3	245
0203000241000	203-24	270	49,0	36,0	8,6	13,3	3	250
0203000251000	203-25	288	54,0	38,0	9,0	13,3	3	320
0203000261000	203-26	288	54,0	38,0	9,5	14,3	3	320
0203000271000	203-27	316	58,0	42,0	10,2	15,4	3	400
0203000281000	203-28	316	58,0	42,0	10,2	15,4	3	400
0203000291000	203-29	339	63,0	45,0	11,2	17,2	3	455
0203000301000	203-30	339	63,0	45,0	11,2	17,2	3	510
0203000321000	203-32	362	66,0	48,0	11,8	18,6	3	600
0203000341000	203-34	390	72,0	50,0	13,5	20,0	3	720

Code	Number	l/mm	h1 mm	h2 mm	t1 mm	t2 mm	Pieces	Weight/g
0203100131000	203A-1/4	103	16,0	11,0	4,0	6,0	12	15
0203100171000	203A-5/16	112	18,5	14,0	4,2	7,0	12	22
0203100191000	203A-3/8	132	21,5	16,5	4,7	7,4	12	33
0203100211000	203A-7/16	142	23,5	18,0	5,3	7,9	12	40
0203100231000	203A-1/2	155	26,0	19,5	5,4	8,4	12	52
0203100241000	203A-9/16	172	30,0	22,5	5,9	9,3	12	70
0203100261000	203A-5/8	196	34,0	25,5	6,3	10,3	6	90
0203100271000	203A-11/16	196	34,0	25,5	6,3	10,3	6	90
0203100281000	203A-3/4	226	40,0	29,5	7,4	11,3	6	130
0203100301000	203A13/16	230	41,0	31,5	7,6	12,3	6	175
0203100311000	203A-7/8	246	46,0	34,0	8,4	12,3	6	170
0203100321000	203A-15/16	270	49,0	36,0	8,6	13,3	3	250
0203100341000	203A-1	288	54,0	38,0	9,0	14,3	3	320
0203100351000	203A-1.1/16	316	58,0	42,0	10,2	15,4	3	400
0203100361000	203A-1.1/8	316	58,0	42,0	10,2	15,4	3	395
0203100371000	203A-1.3/16	339	63,0	45,0	11,2	17,2	3	510
0203100381000	203A-1.1/4	362	66,0	48,0	11,8	18,6	3	600

203XL-...

COMBINATION SPANNER

- long version, both ends fit same nut size
- bent
- matt chrome plated
- ELORA-Chrome-Vanadium 31CrV3 / 1.2208
- according to DIN 3113, Form A, ISO 3318, ISO 7738

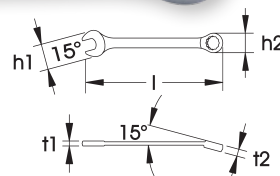

Code	Number	l/mm ┌───┐	h1 mm	h2 mm	t1 mm	t2 mm	Pieces 📦	Weight/g ⚖️
0203000082000	203-8 XL	170	20,3	13,2	4,5	7,5	12	45
0203000092000	203-9 XL	180	22,4	14,6	4,5	8,0	12	55
0203000102000	203-10 XL	190	24,4	16,0	5,0	8,5	12	60
0203000112000	203-11 XL	200	26,4	17,2	5,5	9,0	12	75
0203000122000	203-12 XL	210	28,4	19,0	6,0	9,5	12	90
0203000132000	203-13 XL	225	30,5	20,0	6,5	10,0	12	110
0203000142000	203-14 XL	235	32,5	21,8	7,0	11,0	12	120
0203000172000	203-17 XL	280	38,4	26,5	8,5	14,0	6	210
0203000192000	203-19 XL	310	42,6	29,5	9,5	16,0	6	280
0203000222000	203-22 XL	350	48,7	34,5	11,0	18,0	6	410
0203000242000	203-24 XL	400	52,7	37,5	12,0	19,0	3	535
0203000272000	203-27 XL	450	58,9	42,0	13,0	20,0	3	680
0203000302000	203-30 XL	480	64,8	47,0	14,0	21,0	3	870
0203000322000	203-32 XL	500	67,0	49,5	15,0	22,0	3	1000
0203000362000	203-36 XL	550	73,0	57,0	16,0	24,0	3	1320
0203000412000	203-41 XL	600	86,0	63,0	16,0	26,0	1	1700
0203000462000	203-46 XL	640	96,0	71,0	17,5	27,0	1	2230

203S...XL

COMBINATION SPANNER SET

- carton box packed
- long version, both ends fit same nut size
- bent
- matt chrome plated
- ELORA-Chrome-Vanadium 31CrV3 / 1.2208
- according to DIN 3113, Form A, ISO 3318, ISO 7738



Code	Number	Contents	Pieces 📦	Weight/g ⚖️
0203500802000	203S 8MXL	203XL- 8, 9, 10, 11, 13, 14, 17, 19 mm	1	915
0203501202000	203S 12MXL	203XL- 10, 11, 12, 13, 14, 17, 19, 22, 24, 27, 30, 32 mm	1	1500

203S...M, 203S...AF

COMBINATION SPANNER SET

- carton box packed
- short version, both ends fit same nut size
- bent
- matt chrome plated
- ELORA-Chrome-Vanadium 31CrV3 / 1.2208
- according to DIN 3113, Form A, ISO 3318, ISO 7738



02

mm

AF"

Code	Number	Contents	Pieces	Weight/g	Code	Number	Contents	Pieces	Weight/g
0203500801000	203S 8M	203- 8, 10, 11, 13, 14, 17, 19, 22 mm	1	718	0203600801000	203S 8AF	203A- 5/16, 3/8, 7/16, 1/2, 9/16, 5/8, 11/16, 3/4 AF	1	669
0203500801002	203S 8M-1	203- 8, 9, 10, 11, 13, 14, 17, 19 mm	1	470	0203601001000	203S 10AF	203A- 1/4, 5/16, 3/8, 7/16, 1/2, 9/16, 5/8, 11/16, 3/4, 7/8 AF	1	800
0203501001000	203S 10M	203- 6, 7, 8, 9, 10, 11, 13, 14, 17, 19 mm	1	520	0203601201000	203S 12AF	203A- 5/16, 3/8, 7/16, 1/2, 9/16, 5/8, 11/16, 3/4, 13/16, 7/8, 15/16, 1 AF	1	1723
0203501201000	203S 12M	203- 8, 9, 10, 11, 12, 13, 14, 15, 16, 17, 19, 22 mm	1	1008	0203601601000	203S 16AF	203A- 1/4, 5/16, 3/8, 7/16, 1/2, 9/16, 19/32, 5/8, 11/16, 3/4, 13/16, 7/8, 15/16, 1, 1.1/16, 1.1/4 AF	1	3410
0203501201002	203S 12M-1	203- 10, 11, 12, 13, 14, 17, 19, 22, 24, 27, 30, 32 mm	1	2400					
0203501601000	203S 16M	203- 6, 7, 8, 9, 10, 11, 12, 13, 14, 17, 19, 22, 24, 27, 30, 32 mm	1	2470					
0203501701000	203S 17M	203- 6, 7, 8, 9, 10, 11, 12, 13, 14, 15, 16, 17, 18, 19, 20, 21, 22 mm	1	1380					
0203501801000	203S 18M	203- 8, 9, 10, 11, 12, 13, 14, 16, 17, 18, 19, 21, 22, 24, 27, 30, 32, 34 mm	1	4600					
0203502501000	203S 25M	203- 6, 7, 8, 9, 10, 11, 12, 13, 14, 15, 16, 17, 18, 19, 20, 21, 22, 23, 24, 25, 26, 27, 28, 30, 32 mm	1	4655					
0203502601000	203S 26M	203- 6, 7, 8, 9, 10, 11, 12, 13, 14, 15, 16, 17, 18, 19, 20, 21, 22, 23, 24, 25, 26, 27, 28, 29, 30, 32 mm	1	4840					

203S...MSB, 203S...ASB

COMBINATION SPANNER SET

- in plastic rolling pouch
- with suspension eye
- short version, both ends fit same nut size
- bent
- matt chrome plated
- ELORA-Chrome-Vanadium 31CrV3 / 1.2208
- according to DIN 3113, Form A, ISO 3318, ISO 7738



mm

AF"

Code	Number	Contents	Pieces	Weight/g	Code	Number	Contents	Pieces	Weight/g
0203500801500	203S 8MSB	203- 8, 10, 11, 13, 14, 17, 19, 22 mm	1	816	0203600801500	203S 8ASB	203A- 5/16, 3/8, 7/16, 1/2, 9/16, 5/8, 11/16, 3/4 AF	1	723
0203501201500	203S 12MSB	203- 6, 7, 8, 9, 10, 11, 12, 13, 14, 17, 19, 22 mm	1	948	0203601001500	203S 10ASB	203A- 1/4, 5/16, 3/8, 7/16, 1/2, 9/16, 5/8, 11/16, 3/4, 7/8 AF	1	800

203S...MT, 203S...AFT

COMBINATION SPANNER SET

- ▶ in Tetoron rolling pouch
- ▶ with suspension eye
- ▶ short version, both ends fit same nut size
- ▶ bent
- ▶ matt chrome plated
- ▶ ELORA-Chrome-Vanadium 31CrV3 / 1.2208
- ▶ according to DIN 3113, Form A, ISO 3318, ISO 7738



ELC DRIVE
PROFIL



02



Code	Number	Contents	Pieces	Weight/g	Code	Number	Contents	Pieces	Weight/g
0203500801005	203S 8MT	203- 8, 10, 11, 13, 14, 17, 19, 22 mm	1	929	0203600801005	203S 8AFT	205A- 3/4, 5/16, 3/8, 7/16, 1/2, 9/16, 5/8, 11/16 AF	1	480
0203501201005	203S 12MT	203- 6, 7, 8, 9, 10, 11, 13, 14, 16, 17, 19, 22 mm	1	1167	0203601601005	203S 16AFT	203A- 1/4, 5/16, 3/8, 7/16, 1/2, 9/16, 19/32, 5/8, 11/16, 3/4, 13/16, 7/8, 15/16, 1, 1.1/16, 1.1/4 AF	1	3410
0203501601005	203S 16MT	203- 6, 7, 8, 9, 10, 11, 12, 13, 14, 17, 19, 22, 24, 27, 30, 32 mm	1	3300					
0203502601005	203S 26MT	203- 6, 7, 8, 9, 10, 11, 12, 13, 14, 15, 16, 17, 18, 19, 20, 21, 22, 23, 24, 25, 26, 27, 28, 29, 30, 32 mm	1	5380					

203-KH9

COMBINATION SPANNER SET

- ▶ in black plastic holder
- ▶ short version, both ends fit same nut size
- ▶ bent
- ▶ matt chrome plated
- ▶ ELORA-Chrome-Vanadium 31CrV3 / 1.2208
- ▶ according to DIN 3113, Form A, ISO 3318, ISO 7738

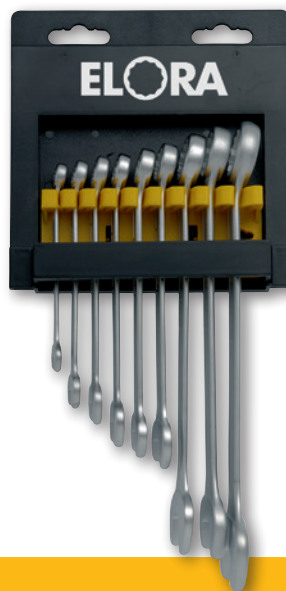

ELC DRIVE
PROFIL



Code	Number	Contents	Pieces	Weight/g
0203500902000	203-KH 9	203- 8, 10, 11, 12, 13, 14, 17, 19, 22 mm	1	1010

You will find the matching OMS-9 module on page no. 27

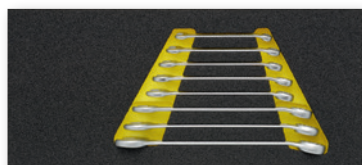

You will find the matching OMS-22 module on page no. 27

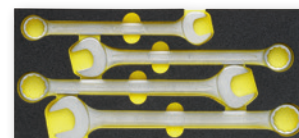

204-...

COMBINATION SPANNER WITH RING RATCHET

- straight version, both ends fit same nut size
- smallest possible swivel angle 5°
- high torque transmission
- ground heads
- matt chrome plated
- using ELORA Adaptors No. 118-..., wrench will be usable as (bit-) ratchet
- ELORA-Chrome-Vanadium 31CrV3 / 1.2208

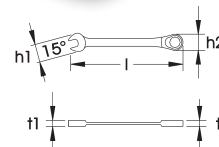



02

mm

AF"

Code	Number	l/mm	h1 mm	h2 mm	t1 mm	t2 mm	Pieces	Weight/g
0204000071000	204-7	140	16,0	17,0	5,0	7,3	6	30
0204000081000	204-8	140	16,0	17,0	5,0	7,3	6	40
0204000091000	204-9	150	18,5	18,5	5,0	7,3	6	45
0204000101000	204-10	160	20,5	20,5	5,5	7,5	6	50
0204000111000	204-11	165	22,5	22,0	6,0	7,8	6	60
0204000121000	204-12	170	25,0	22,5	6,0	8,5	6	75
0204000131000	204-13	180	27,0	25,0	6,5	9,5	6	90
0204000141000	204-14	190	28,5	27,0	7,0	9,5	6	105
0204000151000	204-15	200	31,0	28,5	7,0	9,5	6	125
0204000161000	204-16	210	33,0	29,5	7,0	10,3	6	145
0204000171000	204-17	225	35,0	32,0	8,0	10,3	6	160
0204000181000	204-18	235	37,0	32,0	8,0	10,8	6	190
0204000191000	204-19	245	38,5	34,5	8,5	11,5	6	230
0204000221000	204-22	290	45,0	41,0	9,5	13,5	6	325
0204000241000	204-24	320	45,0	41,0	9,3	14,0	6	460
0204000271000	204-27	355	55,0	49,0	10,0	16,0	6	640
0204000301000	204-30	385	62,0	54,5	10,0	17,0	6	795
0204000321000	204-32	415	67,0	58,0	10,0	17,0	6	955

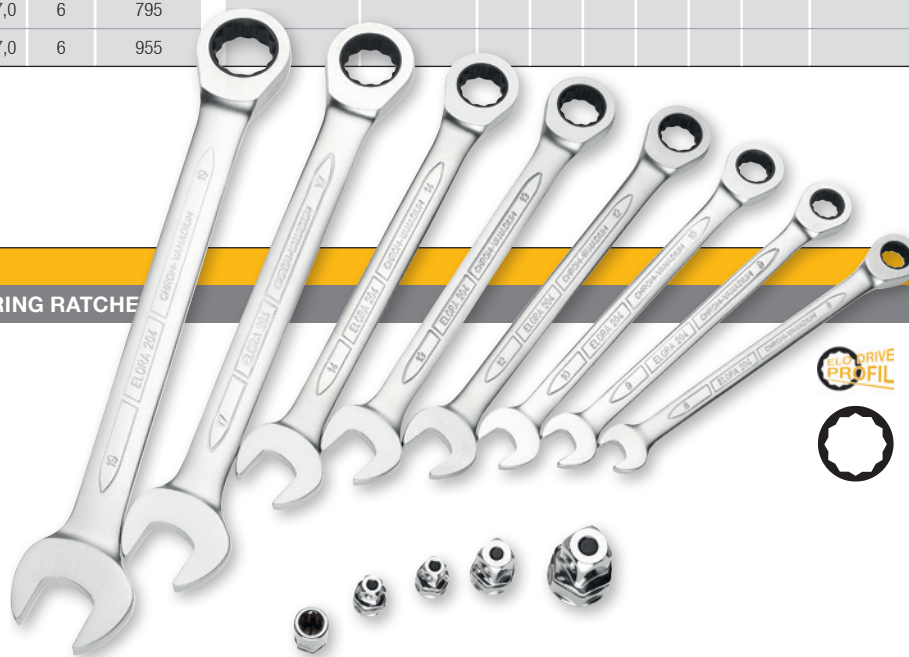
Code	Number	l/mm	h1 mm	h2 mm	t1 mm	t2 mm	Pieces	Weight/g
0204100171000	204A-5/16	140	16,0	17,0	5,0	7,3	6	30
0204100191000	204A-3/8	160	20,5	20,5	5,5	7,3	6	50
0204100211000	204A-7/16	165	22,5	22,0	6,0	7,8	6	60
0204100231000	204A-1/2	180	27,0	25,0	6,5	9,5	6	90
0204100241000	204A-9/16	190	28,5	27,0	7,0	9,5	6	105
0204100261000	204A-5/8	210	33,0	29,5	7,0	10,3	6	145
0204100271000	204A-11/16	225	35,0	32,0	8,0	10,3	6	160
0204100281000	204A-3/4	245	38,5	34,5	8,5	11,5	6	230
0204100301000	204A-13/16	275	43,0	38,0	9,0	12,5	6	320
0204100311000	204A-7/8	290	45,0	41,0	9,5	13,5	6	325
0204100321000	204A-15/16	320	52,0	45,0	9,5	14,0	6	460
0204100341000	204A-1	320	52,0	45,0	9,5	14,0	6	460



204-S8M

SET-COMBINATION SPANNER WITH RING RATCHET

- carton box packed
- straight version, both ends fit same nut size
- smallest possible swivel angle 5°
- high torque transmission
- ground heads
- matt chrome plated
- using ELORA Adaptors No. 118-..., wrench will be usable as (bit-) ratchet
- ELORA-Chrome-Vanadium 31CrV3 / 1.2208

mm

AF"

Code	Number	Contents	Pieces	Weight/g
0204500081000	204-S8M	204- 8, 9, 10, 12, 13, 14, 17, 19 mm 118- 1, 2, 3, 4 Adapter Drives for 1/4", 3/8", 1/2" and 1/4" Bit-Adaptor, details see Art.-No. 118-...	1	1183

Code	Number	Contents	Pieces	Weight/g
0204600801000	204S-8AF	204- 5/16, 3/8, 7/16, 1/2, 9/16, 5/8, 11/16, 3/4 AF 118- 1, 2, 3, 4 Adapter Drives for 1/4", 3/8", 1/2" and 1/4" Bit-Adaptor, details see Art.-No. 118-...	1	810

204-S8MT, 204-S8AFT

SET-COMBINATION SPANNER WITH RING RATCHET

- in Tetoron rolling pouch
- with suspension eye
- straight version, both ends fit same nut size
- smallest possible swivel angle 5°
- high torque transmission
- ground heads
- matt chrome plated
- using ELORA Adaptors No. 118-..., wrench will be usable as (bit-) ratchet
- ELORA-Chrome-Vanadium 31CrV3 / 1.2208



Code	Number	Contents	Pieces	Weight/g	Code	Number	Contents	Pieces	Weight/g
0204500081005	204-S8MT	204- 8, 10, 11, 13, 14, 17, 19, 22 mm	1	1323	0204600801005	204S-8AFT	204- 5/16, 3/8, 7/16, 1/2, 9/16, 5/8, 11/16, 3/4 AF	1	810

204-S8M OMS

SET-COMBINATION SPANNER WITH RING RATCHET

- in solid black metal case with OMS hard foam insert with yellow signal colour, oil and grease resistant
- straight version, both ends fit same nut size
- smallest possible swivel angle 5°
- high torque transmission
- ground heads
- matt chrome plated
- using ELORA Adaptor No. 118-..., wrench will be usable as (bit-) ratchet
- ELORA-Chrome-Vanadium 31CrV3 / 1.2208





Code	Number	Contents	Pieces	Weight/g
0204500081002	204-S8M OMS	204- 8, 9, 10, 12, 13, 14, 17, 19 mm 118- 1, 2, 3, 4 Adapter Drives for 1/4", 3/8", 1/2" and 1/4" Bit-Adaptor, details see Art.-No. 118-...	1	2305

You will find the matching adapters on page no. 86

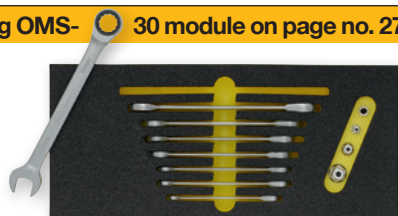

You will find the matching OMS- 30 module on page no. 27



You will find the matching MS-10 module on page no. 44



204-J-...

COMBINATION SPANNER WITH RING RATCHET, REVERSIBLE

- both ends fit same nut size
- bent, reversible ringside
- smallest possible swivel angle 5°
- high torque transmission
- ground heads
- matt chrome plated
- using ELORA Adaptors No. 118-..., wrench will be usable as (bit-) ratchet
- ELORA-Chrome-Vanadium 31CrV3 / 1.2208

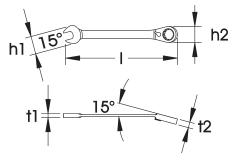

02

Code	Number	l/mm	h1 mm	h2 mm	t1 mm	t2 mm	Pieces	Weight/g
0204000063000	204-J 6	125	15,0	16,0	5,0	7,3	6	30
0204000073000	204-J 7	140	16,0	17,0	5,0	7,3	6	30
0204000083000	204-J 8	140	16,0	17,0	5,0	7,3	6	40
0204000093000	204-J 9	140	18,5	18,5	5,0	7,3	6	45
0204000103000	204-J 10	150	20,5	20,5	5,5	7,5	6	55
0204000113000	204-J 11	160	22,5	22,0	6,0	7,8	6	65
0204000123000	204-J 12	165	25,0	22,5	6,0	8,5	6	85
0204000133000	204-J 13	170	27,0	25,0	6,5	9,5	6	95
0204000143000	204-J 14	180	28,5	27,0	7,0	9,5	6	125
0204000153000	204-J 15	190	31,0	28,5	7,0	9,5	6	125
0204000163000	204-J 16	200	33,0	29,5	7,0	10,3	6	160
0204000173000	204-J 17	210	35,0	32,0	8,0	10,3	6	180
0204000183000	204-J 18	225	37,0	32,0	8,0	10,8	6	205
0204000193000	204-J 19	235	38,5	34,5	8,5	11,5	6	235
0204000223000	204-J 22	290	45,0	41,0	9,5	13,5	6	375
0204000243000	204-J 24	320	45,0	41,0	9,5	14,0	6	505

204-JS8M

SET-COMBINATION SPANNER WITH RING RATCHET, REVERSIBLE

- carton box packed
- both ends fit same nut size
- bent, reversible ringside
- smallest possible swivel angle 5°
- high torque transmission
- ground heads
- matt chrome plated
- using ELORA Adaptors No. 118-..., wrench will be usable as (bit-) ratchet
- ELORA-Chrome-Vanadium 31CrV3 / 1.2208



Code	Number	Contents	Pieces	Weight/g
0204500083000	204-J S8M	204J- 8, 9, 10, 12, 13, 14, 17, 19 mm 118- 1, 2, 3, 4 Adapter Drives for 1/4", 3/8", 1/2" and 1/4" Bit-Adaptor, details see Art.-No. 118-...	1	960

204-JS8MT

SET-COMBINATION SPANNER WITH RING RATCHET, REVERSIBLE

- in Teteron rolling pouch
- with suspension eyes
- both ends fit same nut size
- bent, reversible ringside
- smallest possible swivel angle 5°
- high torque transmission
- ground heads
- matt chrome plated
- using ELORA Adaptors No. 118-..., wrench will be usable as (bit-) ratchet
- ELORA-Chrome-Vanadium 31CrV3 / 1.2208



02

Code	Number	Contents	Pieces	Weight/g
0204500083005	204-JS8MT	204J- 8, 10, 11, 13, 14, 17, 19, 22 mm	1	1500

204-JS8M OMS

SET-COMBINATION SPANNER WITH RING RATCHET, REVERSIBLE

- in solid black metal case with OMS hard foam insert with yellow signal colour, oil and grease resistant
- both ends fit same nut size
- bent, reversible ringside
- smallest possible swivel angle 5°
- high torque transmission
- ground heads
- matt chrome plated
- using ELORA Adaptors No. 118-..., wrench will be usable as (bit-) ratchet
- ELORA-Chrome-Vanadium 31CrV3 / 1.2208



Code	Number	Contents	Pieces	Weight/g
0204500083002	204-JS8M OMS	204J- 8, 9, 10, 12, 13, 14, 17, 19 mm 118- 1, 2, 3, 4 Adapter Drives for 1/4", 3/8", 1/2" and 1/4" Bit-Adaptor, details see Art.-No. 118-...	1	2420

You will find the matching adapters on page no. 86



You will find the matching OMS-33 module on page no. 28



204-R...

COMBINATION SPANNER WITH JOINT-RING RATCHET

- ▶ both ends fit same nut size
- ▶ 180° swivel-type ringside
- ▶ smallest possible swivel angle 5°
- ▶ high torque transmission
- ▶ ground heads
- ▶ matt chrome plated
- ▶ using ELORA Adaptors No. 118-..., wrench will be usable as (bit-) ratchet
- ▶ ELORA-Chrome-Vanadium 31CrV3 / 1.2208



Code	Number	l/mm	Pieces	Weight/g
0204000082000	204-R 8	136	6	40
0204000092000	204-R 9	158	6	59
0204000102000	204-R 10	158	6	59
0204000112000	204-R 11	175	6	70
0204000122000	204-R 12	175	6	77
0204000132000	204-R 13	185	6	85
0204000142000	204-R 14	193	6	103
0204000152000	204-R 15	213	6	130
0204000162000	204-R 16	213	6	140
0204000172000	204-R 17	231	6	184
0204000182000	204-R 18	249	6	190
0204000192000	204-R 19	249	6	194

204-RS8M

SET-COMBINATION SPANNER WITH JOINT RING RATCHET

- ▶ carton box packed
- ▶ both ends fit same nut size
- ▶ 180° swivel-type ringside
- ▶ smallest possible swivel angle 5°
- ▶ high torque transmission
- ▶ ground heads
- ▶ matt chrome plated
- ▶ using ELORA Adaptors No. 118-..., wrench will be usable as (bit-) ratchet
- ▶ ELORA-Chrome-Vanadium 31CrV3 / 1.2208



Code	Number	Contents	Pieces	Weight/g
0204500082000	204-R S8M	204-R- 8, 9, 10, 12, 13, 14, 17, 19 mm 118- 1, 2, 3, 4 Adapter Drives for 1/4", 3/8", 1/2" and 1/4" Bit-Adaptor	1	1020

204RS12M

COMBINATION SPANNER WITH JOINT RING RATCHET SET

- ▶ carton box packed
- ▶ both ends fit same nut size
- ▶ 180° swivel-type ringside
- ▶ smallest possible swivel angle 5°
- ▶ high torque transmission
- ▶ ground heads
- ▶ matt chrome plated
- ▶ using ELORA Adaptors No. 118-..., wrench will be usable as (bit-) ratchet
- ▶ ELORA-Chrome-Vanadium 31CrV3 / 1.2208



Code	Number	Contents	Pieces	Weight/g
0204500122000	204RS 12M	204R- 8, 9, 10, 11, 12, 13, 14, 15, 16, 17, 18, 19 mm	1	1640

You will find the matching **OMS-32 module on page no. 28**



118-.../118S4

ADAPTOR FOR RING RATCHET SPANNER

- ▶ with button for quick release and change of tools
- ▶ chrome-plated, polished
- ▶ Chrome -Vanadium 31CrV3 / 1.2208

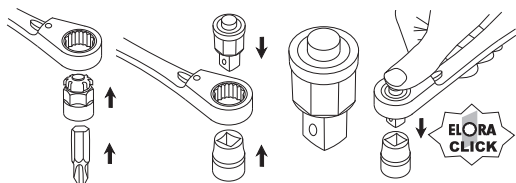

118-1

118-2

118-3

118-4



mm	
12,5	1/2"
10	3/8"
6,3	1/4"

Code	Number	Bit Adaption	Male Square	Drive mm	Pieces	Weight/g
0118000011000	118-1	1/4	-	10	10	10
0118000021000	118-2	-	1/4	10	10	10
0118000031000	118-3	-	3/8	13	10	25
0118000041000	118-4	-	1/2	19	10	55
0118530041000	118 S4	Adaptorset, 4-pcs, 118- 1, 2, 3, 4			1	100

202-..., 202BA-...

COMBINATION SPANNER, EXTRA SHORT

- ▶ extra short series
- ▶ both ends fit same nut size
- ▶ jaw set at 15°, ring 15° bent
- ▶ chrome plated, polished
- ▶ up to 5 mm and 6 BA: ring side in hexagon, all others bi-hexagon
- ▶ ELORA-Chrome-Vanadium 31CrV3 / 1.2208



mm

BA

Code	Number	l/mm	Pieces	Weight/g	Code	Number	l/mm	Pieces	Weight/g
0202000041000	202-4	80	12	10	0202300061000	202BA-6	80	12	10
0202000451000	202-4,5	80	12	10	0202300041000	202BA-4	90	12	13
0202000051000	202-5	80	12	10	0202300021000	202BA-2	100	12	20
0202000551000	202-5,5	90	12	13	0202300001000	202BA-0	110	12	27
0202000061000	202-6	90	12	13					
0202000071000	202-7	100	12	20					
0202000081000	202-8	100	12	20					
0202000091000	202-9	110	12	27					
0202000101000	202-10	110	12	27					

202S...M

COMBINATION SPANNER SET, EXTRA SHORT

- ▶ in black plastic pouch
- ▶ with suspension eye
- ▶ extra short series
- ▶ both ends fit same nut size
- ▶ jaw set at 15°, ring 15° bent
- ▶ chrome plated, polished
- ▶ up to 5 mm and 6 BA: ring side in hexagon, all others bi-hexagon
- ▶ ELORA-Chrome-Vanadium 31CrV3 / 1.2208



mm

BA

Code	Number	Contents	Pieces	Weight/g	Code	Number	Contents	Pieces	Weight/g
0202500601000	202S 6M	202- 5, 5,5, 6, 7, 8, 10 mm	1	142	0202800401000	202S 4BA	202BA- 6, 4, 2, 0 BA	1	110
0202500801000	202S 8M	202- 4, 4,5, 5, 5,5, 6, 7, 8, 10 mm	1	168					

100-..., 100A-...

DOUBLE OPEN ENDED SPANNER

- matt chrome plated, heads ground
- ELORA-Chrome-Vanadium
31CrV3 / 1.2208
- according to DIN 3110,
ISO 3318, ISO 1085, ISO 10102

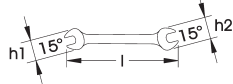

02



Code	Number	l/mm	h1 mm	h2 mm	t mm	Pieces	Weight/g
010004051000	100-4x5	97	11,0	12,5	3,0	12	16
010004551000	100-4,5x5,5	97	11,0	12,5	3,0	12	16
0100055071000	100-5,5x7	125	14,2	16,2	3,5	12	24
010006071000	100-6x7	125	14,2	16,2	3,5	12	24
010006081000	100-6x8	125	14,2	16,2	3,5	12	24
010007081000	100-7x8	140	18,2	20,2	4,0	12	24
010008091000	100-8x9	140	18,2	20,2	4,0	12	36
010008101000	100-8x10	140	18,2	22,1	4,0	12	36
010008111000	100-8x11	140	18,2	22,1	4,0	12	52
010009101000	100-9x10	140	18,2	22,1	4,0	12	36
0100010111000	100-10x11	155	22,1	24,1	4,5	12	52
0100010121000	100-10x12	162	22,1	26,1	4,7	12	52
0100010131000	100-10x13	162	22,1	28,1	4,7	12	74
0100011131000	100-11x13	172	26,1	28,1	5,0	12	74
0100012131000	100-12x13	172	26,1	28,1	5,0	12	74
0100012141000	100-12x14	172	26,1	30,1	5,0	12	74
0100013141000	100-13x14	188	28,1	30,1	5,5	12	95
0100013151000	100-13x15	188	30,1	32,1	5,5	12	95
0100014151000	100-14x15	188	30,1	32,1	5,5	12	95
0100013161000	100-13x16	205	28,1	36,0	6,2	12	124
0100013171000	100-13x17	205	28,1	36,0	6,2	12	124
0100014171000	100-14x17	205	30,1	36,0	6,2	12	124
0100016171000	100-16x17	205	34,1	36,0	6,2	12	126
0100016181000	100-16x18	220	34,1	37,9	7,0	12	126
0100017191000	100-17x19	220	36,0	39,9	7,0	6	170
0100018191000	100-18x19	220	37,9	39,9	7,0	6	170
0100018211000	100-18x21	235	39,9	46,0	7,5	6	185
0100019221000	100-19x22	235	39,9	46,0	7,5	6	235
0100019241000	100-19x24	248	39,9	50,0	8,3	6	235
0100020221000	100-20x22	235	42,1	46,0	7,5	6	240
0100021221000	100-21x22	235	42,1	46,0	7,5	6	240
0100021231000	100-21x23	248	44,0	48,0	8,3	6	270
0100021241000	100-21x24	248	44,0	48,0	8,3	6	270
0100022241000	100-22x24	248	46,0	50,0	8,3	6	290
0100024261000	100-24x26	265	50,0	54,0	8,8	6	340
0100024271000	100-24x27	265	50,0	56,0	8,8	6	340
0100024301000	100-24x30	282	50,0	61,7	9,3	3	375
0100025281000	100-25x28	282	52,0	57,7	9,3	3	375
0100027291000	100-27x29	300	56,0	59,3	9,8	3	450
0100027301000	100-27x30	300	56,0	61,7	9,8	3	450
0100027321000	100-27x32	300	56,0	65,7	9,8	3	460
0100030321000	100-30x32	300	61,7	65,7	9,8	3	460
0100030341000	100-30x34	325	61,7	76,0	10,4	3	650
0100032341000	100-32x34	325	65,7	76,0	10,4	3	650
0100030361000	100-30x36	325	61,7	76,0	10,4	3	650
0100032361000	100-32x36	325	65,7	76,0	10,4	3	650
0100034361000	100-34x36	330	71,0	76,0	10,4	3	670
0100036411000	100-36x41	360	76,0	87,0	12,0	3	860
0100038421000	100-38x42	360	76,0	87,0	12,0	3	860
0100041461000	100-41x46	400	87,0	98,0	12,5	2	1120
0100046501000	100-46x50	450	98,0	107,0	13,0	2	1610
0100055601000	100-55x60	560	113,0	123,0	18,0	1	3020

Code	Number	l/mm	h1 mm	h2 mm	t mm	Pieces	Weight/g
0100113171000	100A-1/4x5/16	125	14,2	16,2	3,5	12	24
0100117191000	100A-5/16x3/8	140	18,2	20,2	4,0	12	36
0100119211000	100A-3/8x7/16	155	22,1	24,1	4,5	12	52
0100121231000	100A-7/16x1/2	172	26,1	28,1	5,0	12	74
0100123241000	100A-1/2x9/16	188	28,1	30,1	5,5	12	95
0100124261000	100A-9/16x5/8	188	30,1	32,1	5,5	12	95
0100126271000	100A-5/8x11/16	205	34,1	36,0	6,2	6	126
0100126281000	100A-5/8x3/4	205	34,1	36,0	6,2	6	126
0100127281000	100A-11/16x3/4	220	36,0	39,9	7,0	6	170
0100128291000	100A-3/4x25/32	220	37,9	39,9	7,0	6	185
0100128311000	100A-3/4x7/8	235	39,9	46,0	7,5	6	235
0100130311000	100A-13/16x7/8	235	42,1	46,0	7,5	6	240
0100132341000	100A-15/16x1	265	50,0	54,0	8,8	6	340
0100134361000	100A-1x1.1/8	265	50,0	56,0	8,8	3	375
0100135361000	100A-1.1/16x1.1/8	300	56,0	59,3	9,8	3	450
0100135381000	100A-1.1/16x1.1/4	300	56,0	65,7	9,8	3	460
0100137391000	100A-1.3/16x1.5/16	325	61,7	76,0	10,4	3	460
0100138401000	100A-1.1/4x1.3/8	325	65,7	76,0	10,4	3	650
0100138411000	100A-1.1/4x1.7/16	325	65,7	76,0	10,4	3	650
0100139421000	100A-1.5/16x1.1/2	325	65,7	76,0	10,4	3	650
0100140421000	100A-1.3/8x1.1/2	325	65,7	76,0	10,4	3	670
0100141441000	100A-1.7/16x1.5/8	360	76,0	87,0	12,0	3	860
0100142441000	100A-1.1/2x1.5/8	360	76,0	87,0	12,0	3	860
0100146491000	100A-1.3/4x2	450	98,0	107,0	13,0	2	1610
0100147491000	100A-1.13/16x2	450	98,0	107,0	13,0	2	1610
0100148501000	100A-1.7/8x2.1/16	450	98,0	107,0	13,0	2	1610
0100152551000	100A-2.3/16x2.3/8	560	113,0	123,0	18,0	1	3020

100S-...M, 100S-...AF

DOUBLE OPEN ENDED SPANNER SET

- ▶ carton boxed packed
- ▶ matt chrome plated, heads ground
- ▶ ELORA-Chrome-Vanadium 31CrV3 / 1.2208
- ▶ according to DIN 3110, ISO 3318, ISO 1085, ISO 10102



Code	Number	Contents	Pieces	Weight/g
0100500601000	100S 6M	100- 8x9, 10x11, 12x13, 14x15, 16x17, 18x19 mm	1	615
0100500801000	100S 8M	100- 6x7, 8x9, 10x11, 12x13, 14x15, 16x17, 18x19, 20x22 mm	1	820
0100500821000	100S 8DIN	100- 6x7, 8x9, 10x11, 12x13, 14x15, 16x17, 18x19, 21x22 mm	1	890
0100501001000	100S 10M	100- 6x7, 8x9, 10x11, 12x13, 14x15, 16x17, 18x19, 20x22, 21x23, 24x27 mm	1	1520
0100501021002	100S 10DIN-1	100- 6x7, 8x9, 10x11, 12x13, 14x15, 16x17, 18x19, 21x22, 24x26, 27x32 mm	1	1617
0100501011000	100S 101M	100- 6x7, 8x9, 10x11, 12x13, 14x15, 16x17, 18x19, 20x22, 24x27, 30x32 mm	1	1715
0100501031000	100S 101DIN	100- 6x7, 8x9, 10x11, 12x13, 14x15, 16x17, 18x19, 21x22, 24x26, 30x34 mm	1	1800
0100501201000	100S 12M	100- 6x7, 8x9, 10x11, 12x13, 14x15, 16x17, 18x19, 20x22, 21x23, 24x27, 25x28, 30x32 mm	1	2280
0100501221000	100S 12DIN	100- 6x7, 8x9, 10x11, 12x13, 14x15, 16x17, 18x19, 20x22, 21x23, 24x26, 27x32 30x34 mm	1	2610

Code	Number	Contents	Pieces	Weight/g
0100600601000	100S 6AF	100A- 5/16x3/8, 7/16x1/2, 9/16x5/8, 11/16x3/4, 13/16x7/8, 15/16x1 AF	1	980
0100600801000	100S 8AF	100A- 1/4x5/16, 5/16x3/8, 7/16x1/2, 9/16x5/8, 11/16x3/4, 13/16x7/8, 15/16x1, 1.1/16x1.1/4 AF	1	1420
0100601201000	100S 12AF	100A- 1/4x5/16, 5/16x3/8, 3/8x7/16, 7/16x1/2, 1/2x9/16, 9/16x5/8, 5/8x11/16, 3/4x25/32, 13/16x7/8, 15/16x1, 1x1.1/8, 1.1/16x1.1/4 AF	1	2060

100-KH 9

DOUBLE OPEN ENDED SPANNER SET

- ▶ in black plastic holder
- ▶ matt chrome plated, heads ground
- ▶ ELORA-Chrome-Vanadium 31CrV3 / 1.2208
- ▶ according to DIN 3110, ISO 3318, ISO 1085, ISO 10102



Code	Number	Contents	Pieces	Weight/g
0100500902000	100-KH 9	100- 6x7, 8x9, 10x11, 12x13, 14x15, 16x17, 18x19, 20x22, 21x23 mm	1	1270

100SH

HOLDER FOR DOUBLE OPEN ENDED SPANNER SET

- ▶ for double open-ended spanner sets of 8, 10 and 12 pcs. ELORA-No.100, for fitting on tool boards and in tool cabinets
- ▶ solid black plastic

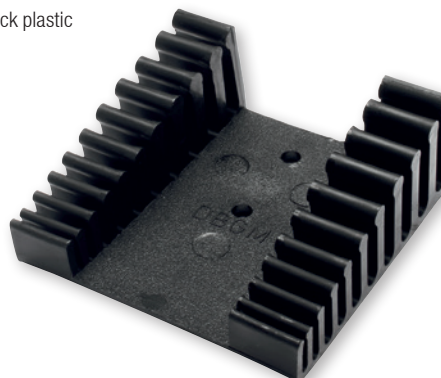

Code	Number	suitable for	Pieces	Weight/g
0100500857000	100S H 8	ELORA-Nr.100S 8M, 100S 8DIN, 100S 8AF	1	19
0100501057000	100S H 10	ELORA-Nr.100S 10M	1	26
0100501257000	100S H 12	ELORA-Nr.100S 12M, 100S 12AF	1	38

100S...MSB, 100S...AFSB

DOUBLE OPEN ENDED SPANNER SET

- in plastic rolling pouch
- with suspension eye
- matt chrome plated, heads ground
- ELORA-Chrome-Vanadium 31CrV3 / 1.2208
- according to DIN 3110, ISO 3318, ISO 1085, ISO 10102



02



Code	Number	Contents	Pieces	Weight/g	Code	Number	Contents	Pieces	Weight/g
0100500601500	100S 6MSB	100- 6×7, 8×9, 10×11, 12×13, 14×15, 16×17 mm	1	495	0100600601500	100S 6AFSB	100A- 1/4×5/16, 5/16×3/8, 7/16×1/2, 9/16×5/8, 11/16×3/4, 13/16×7/8 AF	1	730
0100500801500	100S 8MSB	100- 6×7, 8×9, 10×11, 12×13, 14×15, 16×17, 18×19, 20×22 mm	1	878	0100600801500	100S 8AFSB	100A- 1/4×5/16, 5/16×3/8, 3/8×7/16, 7/16×1/2, 1/2×9/16, 5/8×11/16, 3/4×7/8, 15/16×1 AF	1	1086
0100500821500	100S 8SBDIN	100- 6×7, 8×9, 10×11, 12×13, 14×15, 16×17, 18×19, 21×22 mm	1	830					

You will find the matching OMS-15 module on page no. 26

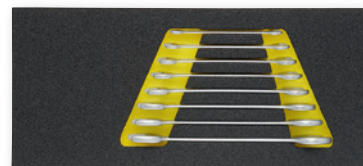

146-..., 146A-...

OBSTRUCTION WRENCH

- for difficult application areas
- small version
- both ends fit same nut size
- extra thin ground jaws
- offset jaw position
- chrome plated, polished
- ELORA-Chrome-Vanadium 31CrV3 / 1.2208

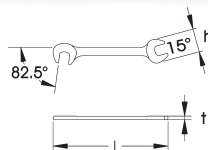

Code	Number	l/mm ┌──┐	h mm	t mm	Pieces ☞	Weight/g ⚖	Code	Number	l/mm ┌──┐	h mm	t mm	Pieces ☞	Weight/g ⚖
0146000401000	146-4x4	74	10,3	3,0	12	6	0146100081000	146A-5/32x5/32	74	10,3	3,0	12	6
0146000451000	146-4,5x4,5	74	10,3	3,0	12	6	0146100091000	146A-3/16x3/16	74	10,3	3,0	12	6
0146000501000	146-5x5	74	10,3	3,0	12	6	0146100111000	146A-7/32x7/32	84	15,7	3,0	12	11
0146000551000	146-5,5x5,5	84	15,7	3,0	12	11	0146100151000	146A-9/32x9/32	84	15,7	3,0	12	11
0146000601000	146-6x6	84	15,7	3,0	12	11	0146100171000	146A-5/16x5/16	93	20,6	3,0	12	20
0146000701000	146-7x7	84	15,7	3,0	12	11	0146100181000	146A-11/32x11/32	93	20,6	3,0	12	20
0146000801000	146-8x8	93	20,6	3,0	12	20	0146100191000	146A-3/8x3/8	93	20,6	3,0	12	20
0146000901000	146-9x9	93	20,6	3,0	12	20	0146100211000	146A-7/16x7/16	114	23,6	3,2	12	28
0146001001000	146-10x10	114	23,6	3,2	12	28	0146100221000	146A-15/32x15/32	136	28,5	3,8	12	45
0146001101000	146-11x11	114	23,6	3,2	12	28	0146100231000	146A-1/2x1/2	136	28,5	3,8	12	45
0146001201000	146-12x12	136	28,5	3,8	12	45	0146100241000	146A-9/16x9/16	136	28,5	3,8	12	45
0146001301000	146-13x13	136	28,5	3,8	12	45	0146100261000	146A-5/8x5/8	156	32,4	4,5	12	65
0146001401000	146-14x14	136	28,5	3,8	12	45							
0146001501000	146-15x15	156	32,4	3,8	12	65							
0146001601000	146-16x16	156	32,4	4,5	12	65							
0146001701000	146-17x17	156	32,4	4,5	12	65							

146S-...

OBSTRUCTION WRENCH SET

- 8- and 10-pieces: in black plastic pouch with suspension eye
- 12- and 14-pieces: carton box packed
- for difficult application areas
- small version
- both ends fit same nut size
- extra thin ground jaws
- offset jaw position
- chrome plated, polished
- ELORA-Chrome-Vanadium 31CrV3 / 1.2208



Code	Number	Contents	Pieces ☞	Weight/g ⚖
0146500801000	146S8M	146- 4x4, 5x5, 6x6, 7x7, 8x8, 9x9, 10x10, 11x11 mm	1	164
0146501001000	146S10M	146- 4x4, 5x5, 6x6, 7x7, 8x8, 9x9, 10x10, 11x11, 12x12, 13x13 mm	1	244
0146501201000	146S12M	146- 4x4, 4,5x4,5, 5x5, 5,5x5,5, 6x6, 7x7, 8x8, 9x9, 10x10, 11x11, 12x12, 13x13 mm	1	259
0146501401000	146S14M	146- 4x4, 4,5x4,5, 5x5, 5,5x5,5, 6x6, 7x7, 8x8, 9x9, 10x10, 11x11, 12x12, 13x13, 14x14, 17x17 mm	1	359

156-..., 156A-..., 156BA-...

MIDGET OPEN ENDED SPANNER

- small version
- thin, ground heads
- chrome plated, polished
- ELORA-Chrome-Vanadium 31CrV3 / 1.2208

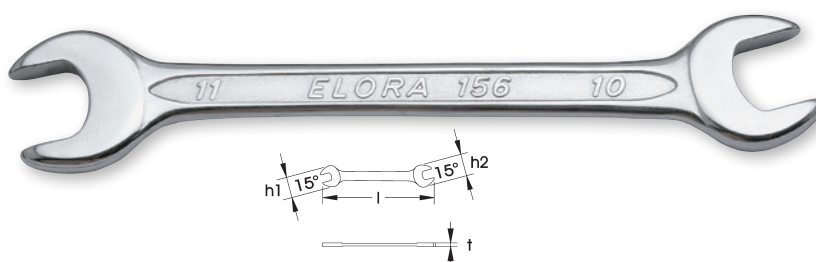

02

Code	Number	l/mm	h1 mm	h2 mm	t mm	Pieces	Weight/g	Code	Number	l/mm	h1 mm	h2 mm	t mm	Pieces	Weight/g
0156025321000	156-2,5x3,2	80	10,0	11,0	3,0	12	8	0156106091000	156A-1/8x3/16	80	10,0	11,0	3,0	12	8
0156003351000	156-3x3,5	80	10,0	11,0	3,0	12	8	0156108101000	156A-5/32x13/64	80	10,0	11,0	3,0	12	8
0156032041000	156-3,2x4	80	10,0	11,0	3,0	12	8	0156109151000	156A-3/16x9/32	80	10,0	11,0	3,0	12	8
0156035451000	156-3,5x4,5	80	10,0	11,0	3,0	12	8	0156111121000	156A-7/32x15/64	86	11,0	12,0	3,0	12	14
0156004451000	156-4x4,5	80	10,0	11,0	3,0	12	8	0156109131000	156A-3/16x1/4	92	13,0	14,0	3,0	12	12
0156004051000	156-4x5	80	10,0	11,0	3,0	12	8	0156113171000	156A-1/4x5/16	98	16,0	18,0	3,2	12	15
0156045551000	156-4,5x5,5	86	11,0	12,0	3,0	12	8	0156115171000	156A-9/32x5/16	98	16,0	18,0	3,2	12	15
0156004061000	156-4x6	86	11,0	12,0	3,0	12	12	0156121231000	156A-7/16x1/2	112	22,0	24,0	4,2	12	26
0156005551000	156-5x5,5	86	11,0	12,0	3,0	12	12								
01560055071000	156-5,5x7	92	13,0	14,0	3,0	12	14								
0156006071000	156-6x7	92	13,0	14,0	3,0	12	14								
0156007081000	156-7x8	98	16,0	18,0	3,2	12	15								
0156008091000	156-8x9	98	16,0	18,0	3,2	12	15								
0156008101000	156-8x10	105	18,0	20,0	4,0	12	22								
0156010111000	156-10x11	105	18,0	20,0	4,0	12	22								
0156012131000	156-12x13	112	22,0	24,0	4,2	12	26								

Code	Number	l/mm	h1 mm	h2 mm	t mm	Pieces	Weight/g
0156308061000	156BA-8x6	80	10,0	11,0	3,0	12	8
0156306041000	156BA-6x4	86	11,0	12,0	3,0	12	12
0156305041000	156BA-5x4	80	10,0	11,0	3,0	12	8
0156305031000	156BA-5x3	86	11,0	12,0	3,0	12	12
0156304021000	156BA-4x2	98	16,0	18,0	3,2	12	15
0156301001000	156BA-1x0	105	18,0	20,0	4,0	12	12

156S...M, 156S...AF, 156S...BA

MIDGET OPEN ENDED SPANNER-SET

- in black plastic pouch
- with suspension eye
- small type
- thin, ground heads
- chrome plated, polished
- ELORA-Chrome-Vanadium 31CrV3 / 1.2208



Code	Number	Contents	Pieces	Weight/g
0156500601000	156S6M	156- 3,2x4, 3,5x4,5, 5x5,5, 6x7, 8x9, 10x11 mm	1	121
0156501201000	156S12M	156- 3x3,5, 3,2x4, 3,5x4,5, 4x5, 5x5,5, 5,5x7, 6x7, 7x8, 8x9, 8x10, 10x11, 12x13 mm	1	208

Code	Number	Contents	Pieces	Weight/g
0156700501000	156S5BA	156BA- 8x6, 6x4, 5x3, 4x2, 1x0 BA	1	115

157S...

IGNITION SPANNER-SET

- nickel plated
- hardened sheet steel



mm
AF¹

Code	Number	Contents	Pieces	Weight/g
0157501103000	157S11M	Open Ended Spanner 4, 4,5, 5, 5,5, 6, 6,5, 7, 7,5 mm 1 Screwdriver, 1 Contact file, 1 Feeler gauge 0,4 mm	1	56
0157601103000	157S11AF	Open Ended Spanner 3/16, 7/32, 1/4, 9/32, 5/16, 11/32, 3/8, 7/16 AF 1 Screwdriver, 1 Contact file, 1 Feeler gauge 0,4 mm	1	62

60-...MB

ADJUSTABLE WRENCH

- with precise and well readable preset-scale in mm graduation
- right-handed roll
- jaw set at 22,5°
- head fine grounded, chrome plated
- ELORA-Chrome-Vanadium 31CrV3 / 1.2208
- according to ISO 6787
- according to ASME B107.100



Code	Number	Span Width mm	l/mm	l/ Inch	Pieces	Weight/g
0060000042000	60-4MB	13	115	4	1	52
0060000062000	60-6MB	24	161	6	1	155
0060000082000	60-8MB	30	207	8	1	310
0060000102000	60-10MB	34	259	10	1	490
0060000122000	60-12MB	39	311	12	1	805
0060000152000	60-15MB	43	386	15	1	1320
0060000182000	60-18MB	53	462	18	1	2040

60-...A

ADJUSTABLE WRENCH

- with precise and well readable preset-scale in mm graduation
- Swedish Pattern
- left-handed roll
- jaw set at 22,5°
- phosphated, head fine grounded
- ELORA-Chrome-Vanadium 31CrV3 / 1.2208
- according to ISO 6787
- ASME B107.100



Code	Number	Span Width mm	l/mm	l/ Inch	Pieces	Weight/g
0060000045100	60-4A	13	115	4	1	52
0060000065100	60-6A	24	161	6	1	155
0060000085100	60-8A	30	207	8	1	310
0060000105100	60-10A	34	259	10	1	490
0060000125100	60-12A	39	311	12	1	805
0060000155100	60-15A	43	386	15	1	1320
0060000185100	60-18A	53	462	18	1	2040
0060000245100	60-24A	62	612	24	1	3590

62-BI-...

ADJUSTABLE WRENCH "XTRA"

- premium industrial quality
- 25% wider jaw capacity
- thinner and longer jaws
- with precise and easy readable preset-scale
- millimeter graduation
- right-handed roll
- jaw set at 22,5°
- ergonomic and slip-resistant plastic handle
- head fine grounded, chrome-plated
- ELORA-Chrome-Vanadium 31CrV3/ 1.2208
- according to ISO 6787



Code	Number	Span Width mm	l/mm	l/Inch	Pieces	Weight/g
0062000062000	62-BI 6	24	162	6,4	1	160
0062000082000	62-BI 8	30	209	8,2	1	310
0062000102000	62-BI 10	34	260	10,2	1	500
0062000122000	62-BI 12	39	312	12,3	1	810

61-MB...

ADJUSTABLE WRENCH "ECONOMY"

- with precise and well readable preset-scale in mm graduation
- head ground, chrome-plated
- Swedish pattern, left-handed roll
- jaw set at 15°
- Chrome-Vanadium 31CrV3 / 1.2208
- according to ISO 6787



Code	Number	Span Width mm	l/mm	l/Inch	Pieces	Weight/g
0061000062000	61-MB 6	19	150	6	1	149
0061000082000	61-MB 8	27	200	8	1	290
0061000102000	61-MB 10	30	250	10	1	493
0061000122000	61-MB 12	33	300	12	1	705
0061000152000	61-MB 15	43	380	15	1	1336
0061000182000	61-MB 18	54	455	18	1	1795

61MB S3

ADJUSTABLE WRENCH SET "ECONOMY"

- carton box packed
- with precise and well readable preset-scale in mm graduation
- head ground, chrome-plated
- Swedish pattern, left-handed roll
- jaw set at 15°
- Chrome-Vanadium 31CrV3 / 1.2208
- according to ISO 6787



Code	Number	Contents	Pieces	Weight/g
0061500031000	61MB S3	61-MB 8, 10, 12	1	1612

02

894-...

SINGLE OPEN-ENDED SPANNER

- jaw set at 15°, gunmetal finished
- high grade tool steel
- according to DIN 894 / ISO 3318



895-...

DOUBLE OPEN-ENDED SPANNER

- jaw set at 15°, gunmetal finished
- high grade tool steel
- according to DIN 895 / ISO 3318 / ISO 1085



Code	Number	l/mm ┌──┐	Pieces 📦	Weight/g ⚖️
089400065100	894-6	75	10	8
089400075100	894-7	80	10	10
089400085100	894-8	95	10	16
089400095100	894-9	100	10	20
089400105100	894-10	105	10	21
089400115100	894-11	115	10	27
089400125100	894-12	125	10	30
089400135100	894-13	130	10	36
089400145100	894-14	140	10	42
089400155100	894-15	145	10	42
089400165100	894-16	160	10	65
089400175100	894-17	160	10	62
089400185100	894-18	170	10	78
089400195100	894-19	170	10	84
089400215100	894-21	195	10	115
089400225100	894-22	195	10	102
089400245100	894-24	215	10	185
089400265100	894-26	215	10	190
089400275100	894-27	240	10	190
089400305100	894-30	250	10	300
089400325100	894-32	260	10	316
089400345100	894-34	260	5	350
089400365100	894-36	300	5	435
089400385100	894-38	300	5	440
089400415100	894-41	340	5	580
089400465100	894-46	380	1	778
089400505100	894-50	410	1	998
089400555100	894-55	460	1	1423
089400605100	894-60	490	1	1491
089400655100	894-65	530	1	1770
089400705100	894-70	575	1	2540
089400755100	894-75	610	1	2600
089400805100	894-80	645	1	3540
089400855100	894-85	690	1	4160
089400955100	894-95	845	1	5460
0894001005100	894-100*	850	1	5500
0894001055100	894-105*	1000	1	7650
0894001105100	894-110*	1000	1	8380

Code	Number	l/mm ┌──┐	Pieces 📦	Weight/g ⚖️
0895006075100	895-6x7	95	10	15
0895007085100	895-7x8	110	10	16
0895008095100	895-8x9	110	10	22
0895008105100	895-8x10	115	10	25
0895009105100	895-9x10	120	10	20
0895009115100	895-9x11	125	10	30
0895009125100	895-9x12	125	10	30
0895010115100	895-10x11	125	10	30
0895010125100	895-10x12	125	10	32
0895010135100	895-10x13	130	10	42
0895010145100	895-10x14	140	10	58
0895012135100	895-12x13	140	10	50
0895012145100	895-12x14	140	10	48
0895013145100	895-13x14	140	10	48
0895013155100	895-13x15	140	10	52
0895013165100	895-13x16	155	10	66
0895013175100	895-13x17	155	10	64
0895014155100	895-14x15	140	10	54
0895014175100	895-14x17	160	10	64
0895016175100	895-16x17	160	10	72
0895016185100	895-16x18	160	10	88
0895017195100	895-17x19	170	10	100
0895017215100	895-17x21	190	10	120
0895017225100	895-17x22	190	10	118
0895018215100	895-18x21	190	10	120
0895019225100	895-19x22	195	10	145
0895019245100	895-19x24	215	10	175
0895022245100	895-22x24	220	10	200
0895022275100	895-22x27	235	10	230
0895024275100	895-24x27	245	10	250
0895024305100	895-24x30	265	10	320
0895027305100	895-27x30	265	10	360
0895027325100	895-27x32	265	10	400
0895030325100	895-30x32	265	10	485
0895030365100	895-30x36	305	5	475
0895032365100	895-32x36	305	5	525
0895036415100	895-36x41	345	5	725
0895041465100	895-41x46	380	1	975
0895046505100	895-46x50	415	1	1166
0895050555100	895-50x55	460	1	1360
0895055605100	895-55x60	480	1	1919
0895065705100	895-65x70	580	1	2900
0895075805100	895-75x80	665	1	4000

890-...

HOOK WRENCH WITH NOSE

- for grooved nuts according to DIN 1804, antifriction bearing bolt, according to DIN 981
- gunmetal finished
- rounded edges for better handling
- high grade tool steel
- according to DIN 1810, Form A



Code	Number	l/mm ┌───┐	for grooved nuts and bearing bolts ┌───┐ mm	Pieces 📦	Weight/g ⚖️
0890000125100	890-12	110	12 - 14	6	23
0890000165100	890-16	110	16 - 20	6	23
0890000255100	890-25	136	25 - 28	6	43
0890000305100	890-30	136	30 - 32	6	50
0890000345100	890-34	170	34 - 36	6	88
0890000405100	890-40	170	40 - 42	6	88
0890000455100	890-45	205	45 - 50	6	155
0890000525100	890-52	205	52 - 55	6	160
0890000585100	890-58	242	58 - 62	6	255
0890000685100	890-68	242	68 - 75	6	255
0890000805100	890-80	280	80 - 90	6	400
0890000955100	890-95	280	95 - 100	6	400
0890001105100	890-110	335	110 - 115	6	750
0890001205100	890-120	335	120 - 130	6	750
0890001355100	890-135	385	135 - 145	3	995
0890001555100	890-155	385	155 - 165	3	995
0890001805100	890-180	470	180 - 195	3	1505
0890002055100	890-205	470	205 - 220	3	1580

890-V...

ADJUSTABLE HOOK WRENCH WITH NOSE

- for grooved nuts to DIN 1804 and bearing nuts to DIN 981
- rounded edges for better handling
- special steel, hardened
- gunmetal finished
- high grade tool steel



Code	Number	l/mm ┌───┐	for grooved nuts and bearing bolts ┌───┐ mm	Pieces 📦	Weight/g ⚖️
0890000205300	890-V 20-42	180	20 - 42	1	100
0890000455300	890-V 45-90	250	45 - 90	1	250
0890000955300	890-V 95-165	335	95 - 165	1	710

890-VG...

HINGED HOOK WRENCH WITH NOSE

- Short design, fits in every pocket and toolbox
- for grooved nuts to DIN 1804 and bearing nuts to DIN 981
- rounded edges for better handling
- high grade tool steel, hardened
- gunmetal finished



Code	Number	l/mm ┌───┐	for grooved nuts and bearing bolts ┌───┐ mm	Pieces 📦	Weight/g ⚖️
0890000205200	890-VG 20-35	135	20 - 35	1	40
0890000355200	890-VG 35-60	175	35 - 60	1	85
0890000605200	890-VG 60-90	240	60 - 90	1	250
0890000905200	890-VG 90-155	300	90 - 155	1	425
0890001555200	890-VG 155-230	420	155 - 230	1	1015

891-...
HOOK WRENCH WITH PIN

- for nuts with radial holes according to DIN 1816 and DIN 548
- rounded edges for better handling
- gunmetal finished
- high grade tool steel
- according to DIN 1810, Form B



02

Code	Number	l/mm 	for Nuts mm 	Pin-Ø mm	Pieces 	Weight/g
0891000125100	891-12	110	12 - 14	2,0	6	23
0891000165100	891-16	110	16 - 18	2,5	6	23
0891000205100	891-20	110	20 - 22	2,5	6	23
0891000255100	891-25	136	25 - 28	3,0	6	49
0891000305100	891-30	136	30 - 32	4,0	6	49
0891000345100	891-34	170	34 - 36	4,0	6	88
0891000405100	891-40	170	40 - 42	4,0	6	88
0891000455100	891-45	205	45 - 50	5,0	6	160
0891000525100	891-52	205	52 - 55	5,0	6	160
0891000585100	891-58	240	58 - 62	5,0	6	260
0891000685100	891-68	240	68 - 75	6,0	6	260
0891000805100	891-80	280	80 - 90	6,0	6	400
0891000955100	891-95	280	95 - 100	8,0	6	400
0891001105100	891-110	335	110 - 115	8,0	6	725
0891001205100	891-120	335	120 - 130	8,0	6	725
0891001355100	891-135	380	135 - 145	8,0	3	1005
0891001555100	891-155	390	155 - 165	8,0	3	1005
0891002055100	891-205	470	205 - 220	10,0	3	1500
0891002305100	891-230	570	230 - 245	10,0	1	2190

892-...

ADJUSTABLE PIN WRENCH

- for nuts with two holes according to DIN 547, spring flange and flange nuts according to DIN 44716
- gunmetal finished
- high grade tool steel
- according to DIN 3116



02

Code	Number	l/mm ┌───┐	Pin-Ø mm	Pin Depth mm	Pieces ☞	Weight/g ⚖
0892000035100	892-3	160	3	4	5	115
0892000045100	892-4	160	4	5	5	120
0892000055100	892-5	215	5	6	5	295
0892000065100	892-6	215	6	7	5	300
0892000085100	892-8	215	8	8	5	305



110-..., 110A-...

DOUBLE-ENDED RING SPANNER

- deep cranked, with thin-walled heads
- matt chrome plated
- break resistance and shatterproof quality minimize risk of injury
- ELORA-Chrome-Vanadium 31CrV3 / 1.2208
- according to DIN 838, ISO 3318, ISO 1085, ISO 10104

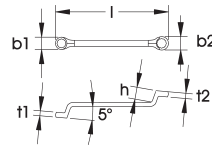

Code	Number	l/mm	b1 mm	b2 mm	t1 mm	t2 mm	h mm	Pieces	Weight/g
0110055071000	110-5,5x7	175	11,0	12,0	6,0	6,0	20,0	12	42
0110006071000	110-6x7	176	10,0	11,5	5,6	6,1	20,0	12	42
0110006081000	110-6x8	175	11,0	12,0	6,0	6,0	20,0	12	50
0110007081000	110-7x8	185	14,0	15,0	6,5	6,5	21,0	12	60
0110007091000	110-7x9	185	14,0	15,0	6,5	6,5	21,0	12	60
0110008091000	110-8x9	190,5	12,9	14,3	6,6	7,1	21,0	12	60
0110008101000	110-8x10	190,5	12,9	15,7	6,6	7,6	21,0	12	60
0110009111000	110-9x11	200	16,0	17,5	7,0	8,0	22,0	12	86
0110010111000	110-10x11	206	15,7	17,0	7,6	8,2	22,0	12	86
0110010121000	110-10x12	206	15,7	18,7	7,6	8,7	22,0	12	86
0110010131000	110-10x13	220,5	15,7	20,0	7,6	9,2	22,0	12	122
0110011131000	110-11x13	215	17,5	20,0	8,0	9,0	22,0	12	122
0110011141000	110-11x14	215	17,5	20,0	8,0	9,0	22,0	12	109
0110012131000	110-12x13	220,5	18,7	20,0	8,7	9,2	23,0	12	122
0110012141000	110-12x14	220,5	18,7	21,6	8,7	9,7	23,0	12	122
0110013141000	110-13x14	236	20,0	21,6	9,2	10,2	24,0	12	150
0110013151000	110-13x15	236	20,0	23,0	9,2	10,2	24,0	12	150
0110013161000	110-13x16	230	22,0	23,0	10,0	10,0	24,0	12	150
0110013171000	110-13x17	250	20,0	26,4	9,2	11,4	25,0	12	185
0110014151000	110-14x15	236	21,6	23,0	9,7	10,1	24,0	12	150
0110014171000	110-14x17	250	24,8	26,4	10,8	11,4	25,0	12	185
0110016171000	110-16x17	250	24,8	26,4	10,8	11,4	26,0	12	210
0110016181000	110-16x18	260	24,8	27,5	10,8	12,0	26,0	12	210
0110017191000	110-17x19	271	26,4	29,0	11,4	12,7	27,0	6	260
0110018191000	110-18x19	271	27,5	29,0	12,0	12,7	27,0	6	260
0110018211000	110-18x21	290	28,0	33,0	12,0	13,0	28,0	6	335
0110019221000	110-19x22	291	29,0	33,0	12,7	13,7	28,0	6	335
0110019241000	110-19x24	311	29,0	36,3	12,7	14,2	28,0	6	335
0110020221000	110-20x22	291	30,4	33,0	13,2	13,8	29,0	6	350
0110021221000	110-21x22	310	31,5	34,0	12,5	13,5	30,0	6	430
0110021231000	110-21x23	311	32,0	34,8	13,2	14,2	30,0	6	430
0110021241000	110-21x24	330	33,0	37,0	13,0	14,0	30,0	3	465
0110022241000	110-22x24	321	33,0	36,3	13,7	14,2	30,0	3	465
0110024261000	110-24x26	331	36,3	39,3	14,2	14,7	32,0	3	460
0110024271000	110-24x27	331	36,3	40,7	14,2	15,2	32,0	3	460
0110024301000	110-24x30	352	36,3	45,0	14,2	16,6	33,0	3	500
0110025281000	110-25x28	352	38,0	42,6	14,7	15,7	32,0	3	500
0110027291000	110-27x29	371	40,7	45,0	15,2	16,6	33,0	3	635
0110027301000	110-27x30	371	40,7	45,0	15,2	16,6	33,0	3	635
0110027321000	110-27x32	371	40,7	47,8	15,2	17,1	35,0	3	635
0110030321000	110-30x32	371	45,0	47,8	16,6	17,1	35,0	3	670
0110030341000	110-30x34	379	45,0	50,0	16,6	17,3	35,0	3	870
0110030361000	110-30x36	402	45,0	53,0	16,6	17,7	35,0	3	870
0110032341000	110-32x34	400	46,0	54,0	17,0	18,0	35,0	3	870
0110032361000	110-32x36	402	47,8	53,0	17,1	17,7	35,0	3	870
0110034361000	110-34x36	420,5	50,0	53,0	17,3	17,7	35,0	3	870
0110036411000	110-36x41	438	53,0	60,8	17,7	19,7	38,0	3	1125
0110038421000	110-38x42	455	55,0	60,0	18,0	20,0	38,0	3	1125
0110041461000	110-41x46	485	60,8	67,5	19,7	20,7	40,0	1	1445
0110046501000	110-46x50	535	67,5	73,4	20,7	22,6	45,0	1	1700
0110055601000	110-55x60*	610	86,0	92,0	25,0	26,0	54,0	1	3455
0110065701000	110-65x70*	685	102,0	108,0	27,0	28,0	58,0	1	4850
0110075801000	110-75x80*	790	120,0	127,0	29,0	30,0	61,0	1	7350
0110085901000	110-85x90*	800	120,0	127,0	29,0	30,0	61,0	1	7000

110S...M, 110S...AF

DOUBLE-ENDED RING SPANNER SET

- carton box packed
- deep cranked, with thin-walled heads
- matt chrome plated
- break resistance and shatterproof quality minimize risk of injury
- ELORA-Chrome-Vanadium 31CrV3 / 1.2208
- according to DIN 838, ISO 3318, ISO 1085, ISO 10104

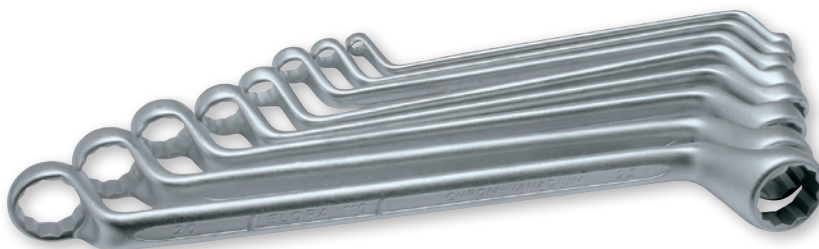

02

mm

AF"

Code	Number	Contents	Pieces	Weight/g
0110500601000	110S 6M	110- 8x9, 10x11, 12x13, 14x15, 16x17, 18x19 mm	1	950
0110500801000	110S 8M	110- 6x7, 8x9, 10x11, 12x13, 14x15, 16x17, 18x19, 20x22 mm	1	1288
0110500821000	110S 8DIN	110- 6x7, 8x9, 10x11, 12x13, 14x15, 16x17, 18x19, 21x22 mm	1	1300
0110501001000	110S 10M	110- 6x7, 8x9, 10x11, 12x13, 14x15, 16x17, 18x19, 20x22, 21x23, 24x27 mm	1	2200
0110501021000	110S 101DIN	110- 6x7, 8x9, 10x11, 12x13, 14x15, 16x17, 18x19, 21x22, 24x26, 30x34 mm	1	2650
0110501011000	110S 101M	110- 6x7, 8x9, 10x11, 12x13, 14x15, 16x17, 18x19, 20x22, 24x27, 30x32 mm	1	2520
0110501021001	110S 10DIN-1	110- 6x7, 8x9, 10x11, 12x13, 14x15, 16x17, 18x19, 21x22, 24x26, 27x32 mm	1	2495
0110501201000	110S 12M	110- 6x7, 8x9, 10x11, 12x13, 14x15, 16x17, 18x19, 20x22, 21x23, 24x27, 25x28, 30x32 mm	1	3320
0110501221000	110S 12DIN	110- 6x7, 8x9, 10x11, 12x13, 14x15, 16x17, 18x19, 20x22, 21x23, 24x26, 27x32, 30x34 mm	1	3630
0110501221002	110S 12DIN-1	110- 6x7, 8x9, 10x11, 12x13, 14x15, 16x17, 18x19, 20x22, 21x23, 24x27, 25x28, 30x32 mm	1	3340

Code	Number	Contents	Pieces	Weight/g
0110600611000	110S 61AF	110A- 1/4x5/16, 3/8x7/16, 1/2x9/16, 5/8x11/16, 3/4x25/32, 13/16x7/8 AF	1	1100
0110600621000	110S 62AF	110A- 3/8x7/16, 1/2x9/16, 5/8x11/16, 3/4x25/32, 13/16x7/8, 15/16x1 AF	1	1480
0110600801000	110S 8AF	110A- 1/4x5/16, 3/8x7/16, 1/2x9/16, 5/8x11/16, 3/4x25/32, 13/16x7/8, 15/16x1, 1.1/16x1.1/4 AF	1	2200
0110601201000	110S 12AF	110A- 1/4x5/16, 5/16x3/8, 3/8x7/16, 7/16x1/2, 1/2x9/16, 9/16x5/8, 5/8x11/16, 3/4x25/32, 13/16x7/8, 15/16x1, 1x1.1/8, 1.1/16x1.1/4 AF	1	3100
0110601401000	110S 14AF	110A- 1/4x5/16, 3/8x7/16, 1/2x9/16, 5/8x11/16, 3/4x25/32, 13/16x7/8, 15/16x1, 1.1/16x1.1/4, 1.1/16x1.1/8, 1.3/16x1.5/16, 1.1/4x1.7/16, 1.7/16x1.5/8, 1.11/16x1.7/8, 1.13/16x2 AF	1	8600

110S...MSB, 110S...AFSB

DOUBLE-ENDED RING SPANNER SET

- in plastic rolling pouch
- with suspension eye
- deep cranked, with thin-walled heads
- matt chrome plated
- break resistance and shatterproof quality minimize risk of injury
- ELORA-Chrome-Vanadium 31CrV3 / 1.2208
- according to DIN 838, ISO 3318, ISO 1085, ISO 10104



mm

AF"

Code	Number	Contents	Pieces	Weight/g
0110500601500	110S 6MSB	110- 6x7, 8x9, 10x11, 12x13, 14x15, 16x17 mm	1	800
0110500801500	110S 8MSB	110- 6x7, 8x9, 10x11, 12x13, 14x15, 16x17, 18x19, 20x22 mm	1	1388
0110500821500	110S 8SBDIN	110- 6x7, 8x9, 10x11, 12x13, 14x15, 16x17, 18x19, 21x22 mm	1	1385

Code	Number	Contents	Pieces	Weight/g
0110600601500	110S 6AFSB	110A- 1/4x5/16, 3/8x7/16, 1/2x9/16, 5/8x11/16, 3/4x25/32, 13/16x7/8 AF	1	1200
0110600801500	110S 8AFSB	110A- 1/4x5/16, 3/8x7/16, 7/16x1/2, 1/2x9/16, 5/8x11/16, 3/4x25/32, 13/16x7/8, 15/16x1 AF	1	1878

112-..., 112A-...

DOUBLE-ENDED RING SPANNER

- ▶ short version
- ▶ deep cranked
- ▶ thin-walled heads
- ▶ chrome plated, polished
- ▶ ELORA-Chrome-Vanadium 31CrV3 / 1.2208



02

mm

AF

Code	Number	l/mm	Pieces	Weight/g	Code	Number	l/mm	Pieces	Weight/g
0112008091000	112-8x9	100	12	28	0112119211000	112A-3/8x7/16	116	12	42
0112010111000	112-10x11	116	12	42	0112121231000	112A-7/16x1/2	136	12	56
0112012131000	112-12x13	136	12	56	0112123241000	112A-1/2x9/16	156	12	85
0112014151000	112-14x15	156	12	85	0112124261000	112A-9/16x5/8	180	12	115
0112016171000	112-16x17	180	12	115	0112126281000	112A-5/8x3/4	181	12	136

112S...M, 112S...AF

DOUBLE-ENDED RING SPANNER SET

- ▶ in plastic pouch
- ▶ with suspension eye
- ▶ short version
- ▶ deep cranked
- ▶ thin-walled heads
- ▶ chrome plated, polished
- ▶ Chrome-Vanadium 31CrV3 / 1.2208





mm

AF

Code	Number	Contents	Pieces	Weight/g	Code	Number	Contents	Pieces	Weight/g
0112500501000	112S 5M	112- 8x9, 10x11, 12x13, 14x15, 16x17 mm	1	419	0112600301000	112S 3AF	112A-3/8x7/16, 1/2x9/16, 5/8x3/4 AF	1	325
					0112600501000	112S 5AF	112A- 3/8x7/16, 7/16x1/2, 1/2x9/16, 9/16x5/8, 5/8x3/4 AF	1	524

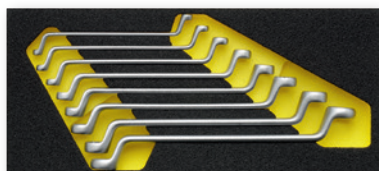
You will find the matching OMS-19 module on page no. 28



113-..., 113BA-...

DOUBLE-ENDED RING SPANNER

- extra short version
- deep cranked
- 4 x 4,5 mm and 6 x 4 BA = hexagon, all others bi-hexagon
- chrome plated, polished
- ELORA-Chrome-Vanadium 31CrV3 / 1.2208



02

mm

BA

Code	Number	l/mm	Pieces	Weight/g	Code	Number	l/mm	Pieces	Weight/g
0113004451000	113-4x4,5	75	12	10	0113306041000	113BA-6x4	75	12	10
0113005551000	113-5x5,5	75	12	10	0113304021000	113BA-4x2	90	12	18
0113006071000	113-6x7	86	12	18	0113302001000	113BA-2x0	105	12	38
0113008091000	113-8x9	86	12	22					
0113010111000	113-10x11	105	12	32					

113S...M

DOUBLE-ENDED RING SPANNER-SET

- in plastic pouch
- with suspension eye
- extra short hexagon-series
- deep cranked
- chrome plated, polished
- Chrome-Vanadium 31CrV3 / 1.2208



mm

BA

Code	Number	Contents	Pieces	Weight/g	Code	Number	Contents	Pieces	Weight/g
0113500301000	113S 3M	113- 4x4,5, 6x7, 10x11 mm	1	70	0113800301000	113S 3BA	113BA- 6x4, 4x2, 2x0 BA	1	125
0113500501000	113S 5M	113- 4x4,5, 5x5,5, 6x7, 8x9, 10x11 mm	1	149					

120-...

DOUBLE-ENDED RING SPANNER, STRAIGHT

- flat and straight pattern
- thin-walled heads
- matt chrome plated
- ELORA-Chrome-Vanadium 31CrV3 / 1.2208
- Ausführung nach DIN 837, Form B, ISO 3318, ISO 1085

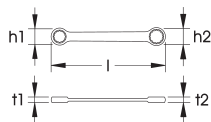

02

Code	Number	h1 mm	h2 mm	t1 mm	t2 mm	l/mm	Pieces	Weight/g	Code	Number	h1 mm	h2 mm	t1 mm	t2 mm	l/mm	Pieces	Weight/g
0120006071000	120-6x7	10,0	11,0	4,0	4,0	100	12	11	0120018211000	120-18x21	30,0	33,0	10,0	10,0	200	6	116
0120008091000	120-8x9	13,0	14,5	4,5	4,5	115	12	16	0120020221000	120-20x22	30,0	33,0	10,0	10,0	200	6	116
0120010111000	120-10x11	15,0	17,0	6,0	6,0	125	12	26	0120021221000	120-21x22	32,0	34,0	10,5	10,5	215	6	140
0120012131000	120-12x13	18,5	20,0	7,0	7,0	140	12	37	0120021231000	120-21x23	32,0	34,0	10,5	10,5	215	6	140
0120012141000	120-12x14	18,5	20,0	7,0	7,0	140	12	37	0120022241000	120-22x24	32,0	34,0	11,5	11,5	215	6	140
0120013161000	120-13x16	20,5	25,0	8,0	8,0	170	12	70	0120024261000	120-24x26	35,0	39,0	11,5	11,5	240	6	200
0120014151000	120-14x15	21,0	22,0	7,5	7,5	155	12	70	0120024271000	120-24x27	35,0	39,0	11,5	11,5	240	6	205
0120016171000	120-16x17	24,0	25,0	8,0	8,0	170	12	70	0120025281000	120-25x28	37,0	41,0	12,5	12,5	265	6	215
0120016181000	120-16x18	24,0	25,0	8,0	8,0	170	12	70	0120030321000	120-30x32	44,0	46,0	13,0	13,0	285	6	290
0120017191000	120-17x19	27,0	28,5	9,0	9,0	185	6	90	0120036411000	120-36x41	51,0	58,0	15,0	15,0	390	3	515
0120018191000	120-18x19	27,0	28,5	9,0	9,0	185	6	90									

120S-...

DOUBLE-ENDED RING SPANNER SET, STRAIGHT

- carton box packed
- flat and straight pattern
- thin-walled heads
- matt chrome plated
- Chrome-Vanadium 31CrV3 / 1.2208
- according to DIN 837, Form B, ISO 3318, ISO 1085



Code	Number	Contents	Pieces	Weight/g
0120500601000	120S 6M	120- 8x9, 10x11, 12x13, 14x15, 16x17, 18x19 mm	1	325
0120500801000	120S 8M	120- 6x7, 8x9, 10x11, 12x13, 14x15, 16x17, 18x19, 20x22 mm	1	469
0120500821000	120S 8DIN	120- 6x7, 8x9, 10x11, 12x13, 14x15, 16x17, 18x19, 21x22 mm	1	460
0120501001000	120S 10M	120- 6x7, 8x9, 10x11, 12x13, 14x15, 16x17, 18x19, 20x22, 21x23, 24x27 mm	1	820
0120501011000	120S 101M	120- 6x7, 8x9, 10x11, 12x13, 14x15, 16x17, 18x19, 20x22, 24x27, 30x32 mm	1	970
0120501201000	120S 12M	120- 6x7, 8x9, 10x11, 12x13, 14x15, 16x17, 18x19, 20x22, 21x23, 24x26, 27x32, 30x34 mm	1	1330
0120501221002	120S 12DIN-1	120- 6x7, 8x9, 10x11, 12x13, 14x15, 16x17, 18x19, 20x22, 21x23, 24x27, 25x28, 30x32 mm	1	1271

115-...

RATCHET RING SPANNER, STRAIGHT

- straight pattern
- chrome plated, polished
- special steel



ELO DRIVE
PROFIL

mm



02

Code	Number	Teeth	Swivel° \triangle	l/mm	Pieces	Weight/g
0115006071000	115-6x7	14+15	25,5+24	117	6	53
0115008091000	115-8x9	16+18	22,5+20	135	6	73
0115010111000	115-10x11	17+18	21+20	143	6	80
0115012131000	115-12x13	17+18	21+20	179	6	145
0115014151000	115-14x15	19+21	20+17	179	6	150
0115016171000	115-16x17	19+21	20+17	209	6	258
0115018191000	115-18x19	21+24	17+15	209	6	260
0115019221000	115-19x22	21+24	17+15	209	6	260
0115021221000	115-21x22	21+24	17+15	227	6	283

115G-...

RATCHET RING SPANNER, BENT

- bent, reversible
- reversible
- chrome plated, polished
- special steel



ELO DRIVE
PROFIL

mm



Code	Number	Teeth	Swivel° \triangle	l/mm	Pieces	Weight/g
0115306071000	115G-6x7	14+15	25,5+24	108	6	59
0115308091000	115G-8x9	16+18	22,5+20	138	6	91
0115310111000	115G-10x11	17+18	21+20	172	6	150
0115312131000	115G-12x13	17+18	21+20	172	6	150
0115314151000	115G-14x15	19+21	20+17	203	6	200
0115316171000	115G-16x17	19+21	20+17	203	6	200
0115318191000	115G-18x19	21+24	17+15	232	6	236
0115321221000	115G-21x22	21+24	17+15	232	6	236

You will find the matching OMS-28 module on page no. 29



You will find the matching OMS-29 module on page no. 29

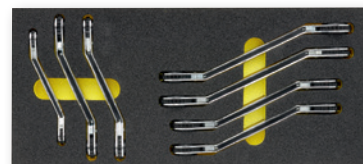

119TXE-...

DOUBLE-ENDED RING SPANNER FOR OUTSIDE TORX®-SCREWS

- for outside TORX®-screws
- straight pattern
- chrome plated
- ELORA-Chrome-Vanadium 31CrV3 / 1.2208
- TORX® = reg. trademark of Acument Intellectual Properties, LLC. USA



Code	Number	l/mm H	Pieces ☞	Weight/g ⚖
0119006081000	119TXE- 6x8	115	12	15
0119010121000	119TXE-10x12	142	12	30
0119014181000	119TXE-14x18	162	12	75
0119020241000	119TXE-20x24	225	6	180

123-...

DOUBLE END SWIVEL SOCKET WRENCH

- thin-walled heads with large swivel range
- matt chrome plated
- heads polished
- ELORA-Chrome-Vanadium 31CrV3 / 1.2208



Code	Number	l/mm H	Pieces ☞	Weight/g ⚖
0123008091000	123-8x9	185	6	60
0123010111000	123-10x11	210	6	112
0123012131000	123-12x13	230	6	170
0123014151000	123-14x15	245	6	220
0123016171000	123-16x17	270	6	270
0123018191000	123-18x19	290	3	360
0123020221000	123-20x22	330	3	500
0123021231000	123-21x23	345	3	530
0123024271000	123-24x27	360	3	790
0123030321000	123-30x32	400	3	950

121-..., 121A-...

OPEN RING SPANNER

- for flare nuts e.g. at gasoline or hydraulic pipes
- open rings are 15° bent
- ring opening set at 30°
- up to 13 x 14 mm and 7/16"x1/2" AF= hex. pattern, all other: bi-hex. pattern,
- matt chrome plated
- ELORA-Chrome-Vanadium 31CrV3 / 1.2208
- according to DIN 3118

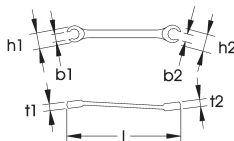

Code	Number	l/mm	h1 mm	h2 mm	b1 mm	b2 mm	t1 mm	t2 mm	Pieces	Weight/g
0121008101000	121-8x10	150	16,5	20,0	6,0	7,0	7,5	9,0	12	48
0121009111000	121-9x11	150	16,5	20,0	6,5	8,5	7,5	9,0	12	48
0121010111000	121-10x11	165	20,0	22,0	7,0	8,5	9,0	9,5	12	67
0121010121000	121-10x12	165	20,0	24,0	7,0	9,0	8,5	10,0	12	67
0121011131000	121-11x13	165	20,0	23,5	8,5	10,0	8,5	10,0	12	67
0121012131000	121-12x13	190	23,5	26,0	9,0	10,0	10,0	11,0	12	100
0121012141000	121-12x14	190	23,5	26,0	9,0	11,0	10,0	11,0	12	100
0121013141000	121-13x14	190	23,5	26,0	9,0	11,0	10,0	11,0	12	100
0121013151000	121-13x15	190	23,5	26,0	10,0	12,0	10,0	11,0	12	100
0121014161000	121-14x16	200	25,0	29,0	11,0	14,0	11,0	12,5	12	135
0121014171000	121-14x17	200	25,0	29,0	11,0	14,0	11,0	12,5	12	135
0121016181000	121-16x18	210	30,0	32,0	14,0	15,0	12,0	13,0	12	160
0121017191000	121-17x19	210	30,0	32,0	14,0	15,0	12,0	13,0	12	160
0121019221000	121-19x22	230	32,0	36,0	15,0	17,0	13,5	15,0	6	190
0121021231000	121-21x23	245	37,0	40,0	16,5	18,0	14,0	15,5	6	240
0121022241000	121-22x24	245	37,0	40,0	17,0	18,0	14,0	15,5	6	240
0121024271000	121-24x27	260	40,0	44,0	18,0	20,0	16,0	16,5	6	325
0121030321000	121-30x32	288	48,0	52,0	22,0	24,0	20,0	21,5	6	465

121S8M

OPEN RING SPANNER SET

- carton box packed
- for flare nuts e.g. at gasoline or hydraulic pipes
- open rings are 15° bent
- ring opening set at 30°
- up to 13 x 14 mm = hex. pattern, all other: bi-hex. pattern,
- matt chrome plated
- ELORA-Chrome-Vanadium 31CrV3 / 1.2208
- according to DIN 3118



Code	Number	Contents	Pieces	Weight/g
0121500801000	121S 8M	121- 8x10, 9x11, 12x14, 13x15, 14x16, 17x19, 21x23, 22x24 mm	1	1180



Code	Number	l/mm —	h1 mm	h2 mm	b1 mm	b2 mm	t1 mm	t2 mm	Pieces 	Weight/g
0121117191000	121A-5/16x3/8	150	16,5	20,0	6,0	7,0	7,5	9,0	12	48
0121119211000	121A-3/8x7/16	165	20,0	22,0	7,0	8,5	9,0	9,5	12	67
0121121231000	121A-7/16x1/2	165	20,0	24,0	7,0	9,0	8,5	10,0	12	65
0121124261000	121A-9/16x5/8	200	25,0	29,0	11,0	14,0	11,0	12,5	12	135
0121126281000	121A-5/8x3/4	210	30,0	32,0	14,0	15,0	12,0	13,0	12	160
0121128311000	121A-3/4x7/8	230	32,0	36,0	15,0	17,0	13,5	15,0	6	190
0121134361000	121A-1x1.1/8	260	40,0	44,0	18,0	20,0	16,0	16,5	6	325

You will find the matching OMS-31 module on page no. 29

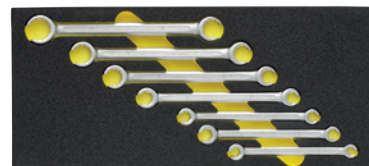

117-...

RING RATCHET-SPANNER, HINGED

- for awkward areas with limited access for hydraulic-, pneumatic and other bolted connections within a conduit system
- smallest swivel angle 30°
- chrome-plated, head gunmetal finished
- special steel



02

Code	Number	l/mm	Pieces	Weight/g
0117000101000	117-10	155	6	82
0117000111000	117-11	155	6	83
0117000121000	117-12	155	6	85
0117000131000	117-13	155	6	90
0117000141000	117-14	155	6	90
0117000171000	117-17	210	6	148
0117000191000	117-19	210	6	156
0117000221000	117-22	210	3	270
0117000241000	117-24	219	3	610
0117000271000	117-27	315	3	610
0117000321000	117-32	319	3	610

117S...

RING RATCHET-SPANNER-SET, HINGED

- carton box packed
- for awkward areas with limited access for hydraulic-, pneumatic and other bolted connections within a conduit system
- smallest swivel angle 30°
- chrome-plated, head gunmetal finished
- special steel



Code	Number	Contents	Pieces	Weight/g
0117500051000	117 S6	117- 10, 11, 12, 13, 14, 17 mm	1	840
0117500111000	117 S11	117- 10, 11, 12, 13, 14, 17, 19, 22, 24, 27, 32 mm	1	2834

122-..., 122A-...

OBSTRUCTION RING SPANNER

- especially suitable for work on engines
e.g. bolts on alternator,
carburetor and starter
- with thin-walled rings
- matt chrome plated
- ELORA-Chrome-Vanadium 31CrV3 / 1.2208
- according to ISO 3318



02

mm

AF^m

Code	Number	l/mm ┌─┐	Pieces ☞	Weight/g ⚖
0122010121000	122-10x12	150	6	80
0122011131000	122-11x13	150	6	55
0122012131000	122-12x13	150	6	55
0122013151000	122-13x15	185	6	110
0122013171000	122-13x17	185	6	110
0122014161000	122-14x16	185	6	110
0122014171000	122-14x17	185	6	110
0122015171000	122-15x17	185	6	110
0122019211000	122-19x21	230	6	195
0122019221000	122-19x22	230	6	195

Code	Number	l/mm ┌─┐	Pieces ☞	Weight/g ⚖
0122123251000	122A-1/2x9/16	185	6	110
0122124261000	122A-9/16x5/8	185	6	110

88-...

SINGLE END RING SPANNER

- straight pattern
- with suspension eye
- sand-blasted
- further sizes on request
- ELORA-Tempering steel C35 / 1.0501
- according to DIN 3111

mm



Code	Number	l/mm ┌─┐	Pieces ☞	Weight/g ⚖
0088000131000	88-13	138	6	45
0088000141000	88-14	138	6	45
0088000171000	88-17	155	6	75
0088000191000	88-19	171	6	100
0088000221000	88-22	190	6	140
0088000241000	88-24	215	3	160
0088000271000	88-27	230	3	200
0088000301000	88-30	254	3	280
0088000321000	88-32	265	3	350
0088000361000	88-36	295	1	500
0088000411000	88-41	330	1	750
0088000461000	88-46	365	1	950

Code	Number	l/mm ┌─┐	Pieces ☞	Weight/g ⚖
0088000501000	88-50	400	1	1200
0088000551000	88-55	442	1	1600
0088000601000	88-60	475	1	1800
0088000651000	88-65	510	1	2400
0088000701000	88-70	555	1	2700
0088000751000	88-75	590	1	3400
0088000801000	88-80	620	1	3800
0088000851000	88-85	665	1	4400
0088000901000	88-90	698	1	5300
0088000951000	88-95	700	1	5800

86-..., 86A-...

RING SLOGGING SPANNER

- heavy, drop-forged type
- sand-blasted
- further sizes on request
- from 22 mm until 115 mm and all AF-sizes:
ELORA-Chrome-Vanadium 31CrV3 / 1.2208
- from 120 mm until 230 mm:
ELORA-Tempering steel C35 / 1.0501
- according to DIN 7444



02

mm

AF^m

Code	Number	l/mm 	Pieces 	Weight/g
0086000221000	86-22	165	1	230
0086000241000	86-24	165	1	230
0086000271000	86-27-1.1/16	180	1	350
0086000281000	86-28-1.1/16	180	1	350
0086000301000	86-30	190	1	465
0086000321000	86-32	190	1	465
0086000341000	86-34	190	1	465
0086000361000	86-36	210	1	570
0086000381000	86-38-1.1/2	210	1	570
0086000411000	86-41-1.5/8	230	1	760
0086000461000	86-46-1.13/16	242	1	950
0086000501000	86-50	254	1	1120
0086000551000	86-55	268	1	1560
0086000581000	86-58	283	1	1625
0086000601000	86-60	283	1	1625
0086000651000	86-65	300	1	2130
0086000701000	86-70	330	1	2930
0086000751000	86-75	330	1	2800
0086000801000	86-80	360	1	4020
0086000851000	86-85	360	1	3900
0086000901000	86-90	390	1	5610
0086000951000	86-95	390	1	5610
0086001001000	86-100	420	1	6840
0086001051000	86-105	420	1	6450
0086001101000	86-110	445	1	8090
0086001151000	86-115	445	1	7610
0086001201000	86-120	480	1	10020
0086001251000	86-125	480	1	8600
0086001301000	86-130	510	1	13200
0086001351000	86-135	510	1	12900
0086001401000	86-140	520	1	13800
0086001451000	86-145	580	1	19200
0086001501000	86-150	580	1	18000
0086001551000	86-155	580	1	19200
0086001601000	86-160	580	1	19200
0086001651000	86-165	630	1	28600

Code	Number	l/mm 	Pieces 	Weight/g
0086100341000	86A-1	165	1	230
0086000271000	86-27-1.1/16	180	1	230
0086100361000	86A-1.1/8	180	1	350
0086100371000	86A-1.3/16	190	1	465
0086100381000	86A-1.1/4	190	1	465
0086100391000	86A-1.5/16	190	1	465
0086100401000	86A-1.3/8	210	1	570
0086100411000	86A-1.7/16	210	1	570
0086000381000	86-38-1.1/2	210	1	570
0086100431000	86A-1.9/16	230	1	760
0086000411000	86-41-1.5/8	230	1	760
0086100451000	86A-1.11/16	230	1	760
0086100461000	86A-1.3/4	242	1	950
0086000461000	86-46-1.13/16	242	1	950
0086100481000	86A-1.7/8	242	1	950
0086100481001	86A-1.15/16	254	1	1120
0086100491000	86A-2	254	1	1120
0086100501000	86A-2.1/16	254	1	1120
0086100511000	86A-2.1/8	268	1	1560
0086100521000	86A-2.3/16	268	1	1560
0086100531000	86A-2.1/4	268	1	1560
0086100541000	86A-2.5/16	283	1	1625
0086100551000	86A-2.3/8	283	1	1625
0086100561000	86A-2.7/16	283	1	1625
0086100571000	86A-2.1/2	283	1	1625
0086100581000	86A-2.9/16	300	1	2020
0086100591000	86A-2.5/8	300	1	2000
0086100601000	86A-2.3/4	330	1	2970
0086100611000	86A-2.13/16	330	1	3000
0086100611001	86A-2.7/8	330	1	2840
0086100621000	86A-2.15/16	330	1	2940
0086100631000	86A-3	330	1	2940
0086100641000	86A-3.1/8	360	1	4000
0086100651000	86A-3.1/4	360	1	3900
0086100661000	86A-3.3/8	360	1	4000
0086100671000	86A-3.1/2	360	1	3490
0086100681000	86A-3.5/8	385	1	5400
0086100691000	86A-3.3/4	385	1	5590
0086100701000	86A-3.7/8	388	1	5400
0086100711000	86A-4	420	1	6530
0086100721000	86A-4.1/8	420	1	6530
0086100731000	86A-4.1/4	450	1	8600
0086100741000	86A-4.1/2	450	1	8600

86S-13

RING SLOGGING SPANNER-SET

- heavy, drop-forged type
- sand-blasted
- on yellow metal display board
- Size: 895 x 500 mm
- further sizes on request
- ELORA-Chrome-Vanadium 31CrV3 / 1.2208
- according to DIN 7444



02



Code	Number	Contents	Pieces 	Weight/g
0086501301000	86S-13	86-30, 32, 36, 38, 41, 46, 50, 55, 60, 65, 70, 75, 80 mm	1	26000
0086500006000	86L	empty	1	6800

87-..., 87A-...

OPEN END SLOGGING SPANNER

- heavy, drop-forged type
- sand-blasted
- further sizes on request
- up to 110 mm and all AF-Sizes:
Chrom-Vanadium 31CrV3 / 1.2208
- from 115 mm: ELORA-Tempering steel C35 / 1.0501
- according to DIN 133



mm

AF^m

Code	Number	l/mm ┌─┐	Pieces ☞	Weight/g ⚖	Code	Number	l/mm ┌─┐	Pieces ☞	Weight/g ⚖
0087000241000	87-24	180	1	340	0087100341000	87A-1	175	1	310
0087000271000	87-27	180	1	340	0087100351000	87A-1.1/16	180	1	345
0087000301000	87-30	190	1	440	0087100361000	87A-1.1/8	180	1	360
0087000321000	87-32	190	1	425	0087100371000	87A-1.3/16	190	1	440
0087000361000	87-36	215	1	750	0087100381000	87A-1.1/4	190	1	425
0087000381000	87-38 / 1.1/2	215	1	750	0087100391000	87A-1.5/16	190	1	490
0087000411000	87-41	230	1	960	0087100411000	87A-1.7/16	215	1	750
0087000461000	87-46 / 1.3/4	200	1	1130	0087000381000	87-38 / 1.1/2	215	1	620
0087000501000	87-50	270	1	1640	0087100431000	87A-1.9/16	230	1	640
0087000551000	87-55	297	1	2080	0087100441000	87A-1.5/8	230	1	930
0087000601000	87-60	310	1	2370	0087100451000	87A-1.11/16	230	1	930
0087000651000	87-65	340	1	3250	0087000461000	87-46 / 1.3/4	200	1	920
0087000701000	87-70	370	1	4020	0087100471000	87A-1.13/16	250	1	1150
0087000751000	87-75	395	1	4670	0087100481000	87A-1.7/8	250	1	1150
0087000801000	87-80	408	1	6610	0087100481001	87A-1.15/16	270	1	1460
0087000851000	87-85	408	1	6470	0087100491000	87A-2	270	1	1460
0087000901000	87-90	445	1	7800	0087100501000	87A-2.1/16	270	1	1620
0087000951000	87-95	445	1	8710	0087100511000	87A-2.1/8	275	1	1860
0087001001000	87-100	480	1	12780	0087100521000	87A-2.3/16	300	1	1900
0087001051000	87-105	480	1	12530	0087100531000	87A-2.1/4	300	1	2070
0087001101000	87-110	510	1	13500	0087100541000	87A-2.5/16	320	1	2500
0087001151000	87-115	500	1	16350	0087100551000	87A-2.3/8	315	1	2470
0087001201000	87-120	545	1	16000	0087100561000	87A-2.7/16	315	1	2540
0087001251000	87-125	545	1	16000	0087100571000	87A-2.1/2	342	1	3460
0087001301000	87-130*	575	1	19000	0087100581000	87A-2.9/16	338	1	3110
0087001351000	87-135*	575	1	19000	0087100591000	87A-2.5/8	335	1	2970
0087001401000	87-140*	575	1	20700	0087100601000	87A-2.3/4	365	1	4140
0087001451000	87-145*	640	1	27100	0087100611000	87A-2.13/16	375	1	4450
0087001501000	87-150*	640	1	27300	0087100611001	87A-2.7/8	365	1	3950
0087001551000	87-155*	640	1	27400	0087100621000	87A-2.15/16	360	1	4000
0087001601000	87-160*	715	1	25500	0087100631000	87A-3	390	1	4730
0087001651000	87-165*	715	1	40000	0087100641000	87A-3.1/8	405	1	6700
0087001701000	87-170*	715	1	39000	0087100651000	87A-3.1/4	405	1	6580
0087001751000	87-175*	715	1	39000	0087100661000	87A-3.3/8	405	1	6570
0087001801000	87-180*	715	1	39500	0087100671000	87A-3.1/2	445	1	7800
0087001851000	87-185*	715	1	36000	0087100681000	87A-3.5/8	440	1	8770
0087001901000	87-190*	800	1	53300	0087100691000	87A-3.3/4	445	1	7800
0087001951000	87-195*	800	1	53000	0087100701000	87A-3.7/8	485	1	11500
0087002001000	87-200*	800	1	53000	0087100711000	87A-4	485	1	11500
0087002101000	87-210*	800	1	53400	0087100721000	87A-4.1/8	485	1	11500
0087002201000	87-220*	800	1	55000	0087100731000	87A-4.1/4	500	1	15650
					0087100741000	87A-4.1/2	510	1	13500

85-..., 85A-...

CONSTRUCTION RING SPANNER

- heavy, deep cranked pattern
- for use with tommy bar tubes ELORA-No. 855
- matt chrome plated
- ELORA-Chrome-Vanadium 31CrV3 / 1.2208
- according to DIN 475



02

mm

AF"

Code	Number	l/mm	Pieces	Weight/g	Code	Number	l/mm	Pieces	Weight/g
0085000221000	85-22	180	1	420	0085100311000	85A-7/8	180	1	370
0085000241000	85-24	180	1	430	0085100341000	85A-1	180	1	370
0085000271000	85-27	190	1	480	0085100351000	85A-1.1/16	190	1	410
0085000301000	85-30	195	1	490	0085100361000	85A-1.1/8	185	1	410
0085000321000	85-32	230	1	720	0085100381000	85A-1.1/4	230	1	720
0085000361000	85-36	240	1	840	0085100391000	85A-1.5/16	235	1	750
0085000381000	85-38 / 1.1/2	240	1	840	0085100401000	85A-1.3/8	240	1	840
0085000411000	85-41	250	1	935	0085100411000	85A-1.7/16	245	1	840
0085000461000	85-46 / 1.13/16	260	1	1300	0085000381000	85-38 / 1.1/2	240	1	840
0085000501000	85-50	290	1	1450	0085100431000	85A-1.9/16	250	1	935
0085000551000	85-55	305	1	1500	0085100441000	85A-1.5/8	250	1	935
0085000601000	85-60	345	1	2200	0085100451000	85A-1.11/16	250	1	935
0085000651000	85-65	350	1	2680	0085000461000	85-46 / 1.13/16	260	1	1300
0085000701000	85-70	360	1	2900	0085100481000	85A-1.7/8	260	1	1300
0085000751000	85-75	375	1	3060	0085100491000	85A-2	280	1	1450
0085000801000	85-80	390	1	3780	0085100501000	85A-2.1/16	290	1	1450
0085000851000	85-85	390	1	4100	0085100511000	85A-2.1/8	290	1	1450
0085000901000	85-90	410	1	4790	0085100521000	85A-2.3/16	290	1	1500
0085000951000	85-95	410	1	4950	0085100531000	85A-2.1/4	290	1	1500
0085001001000	85-100	410	1	4900	0085100551000	85A-2.3/8	345	1	2400
0085001051000	85-105	410	1	4900	0085100571000	85A-2.1/2	345	1	2400
					0085100581000	85A-2.9/16	355	1	2600
					0085100601000	85A-2.3/4	355	1	2800
					0085100621000	85A-2.15/16	375	1	3000
					0085100641000	85A-3.1/8	385	1	3920
					0085100661000	85A-3.3/8	385	1	4100
					0085100681000	85A-3.5/8	410	1	4950
					0085100701000	85A-3.7/8	415	1	4900
					0085100711000	85A-4	415	1	4900
					0085100721000	85A-4.1/8	415	1	4900

855-...

TOMMY BAR TUBE

- for use with construction ring spanners ELORA-No. 85
- chrome plated
- steel tube



Code	Number	for 85-mm 	for 85-AF 	l/mm	Pieces	Weight/g
0855000221000	855-22	22, 24, 27, 30	7/8, 1, 1.1/16, 1.1/8, 1.3/16 AF	460x23	1	600
0855000321000	855-32	32, 36, 38, 41	1.1/4, 1.5/16, 1.3/8, 1.7/16, 1.1/2, 1.9/16, 1.5/8, 1.11/16 AF	610x27	1	1009
0855000461000	855-46	46, 50, 55	1.3/4, 1.13/16, 1.7/8, 2, 2.1/16, 2.1/8, 2.3/16, 2.1/4 AF	760x30	1	2150
0855000601000	855-60	60, 65, 70, 75, 80, 85, 90, 95, 100, 105	2.3/8, 2.1/2, 2.9/16, 2.3/4, 2.15/16, 3.1/8, 3.3/8 AF	865x37	1	2900

85S.../85L...

CONSTRUCTION RING SPANNER-SET

- heavy, deep cranked pattern
- matt chrome plated
- on yellow metal display board
- Size: 895 x 725 mm
- ELORA-Chrome-Vanadium 31CrV3 / 1.2208
- according to DIN 475



Code	Number	Contents	Pieces	Weight/g
0085501701000	85S-17M	85- 27, 30, 32, 36, 41, 46, 50, 55, 60, 65, 70, 75, 80 mm 855- 22, 855-32, 855-46, 855-60	1	37000
0085601601000	85S-16AF	85- 1.1/4, 1.7/16, 1.5/8, 1.13/16, 2, 2.3/16, 2.3/8, 2.9/16, 2.3/4, 2.15/16, 3.1/8, 3.3/8 AF 855- 22, 855-32, 855-46, 855-60	1	33000
0085400106000	85L	empty	1	7900

206-...

HEXAGON TUBULAR BOX SPANNER, SOLID

- for use with open end spanner, stepped tommy bar ELORA-No. 212-2 or ELORA-No. 212-3
- solid forged version
- chrome plated, heads polished
- tommy bars are not included
- Chrome-Vanadium 31CrV3 / 1.2208
- according to DIN 896, form A / ISO 2236/1085

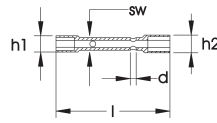

02

Code	Number	l/mm	h1 mm	h2 mm	sw mm	d mm	Pieces	Weight/g
0206006071000	206-6x7	103	10,0	11,0	7,0	3,25	12	30
0206008091000	206-8x9	108	12,5	13,5	9,0	3,5	12	60
0206010111000	206-10x11	120	15,0	16,0	11,0	4,5	12	80
0206012131000	206-12x13	138	17,3	18,8	13,0	5,5	6	125
0206013171000	206-13x17	153	19,8	23,9	16,0	7,2	6	140
0206014151000	206-14x15	145	19,8	21,1	14,0	7,2	6	143
0206016171000	206-16x17	153	22,4	23,9	16,0	7,2	6	150
0206016181000	206-16x18*	158	23,9	25,2	18,0	8,3	6	150
0206018191000	206-18x19	163	25,2	26,2	18,0	8,3	6	235
0206018211000	206-18x21	168	26,2	28,8	20,0	8,3	6	235
0206020221000	206-20x22	173	27,6	30,1	20,0	8,3	3	290
0206021231000	206-21x23	183	28,8	30,8	21,0	10,0	3	340
0206024261000	206-24x26	193	32,6	34,6	24,0	11,5	3	410
0206024271000	206-24x27	193	32,6	36,6	24,0	11,5	3	445

206S...M

HEXAGON TUBULAR BOX SPANNER SET, SOLID

- carton box packed
- for use with open end spanner, stepped tommy bar ELORA-No. 212-2 or ELORA-No. 212-3
- solid forged version
- chrome plated, heads polished
- tommy bars are not included
- Chrome-Vanadium 31CrV3 / 1.2208
- according to DIN 896, form A / ISO 2236/1085



Code	Number	Contents	Pieces	Weight/g
0206500801000	206S 8M	206- 6×7, 8×9, 10×11, 12×13, 14×15, 16×17, 18×19, 20×22 mm	1	1235
0206501001000	206S 10M	206- 6×7, 8×9, 10×11, 12×13, 14×15, 16×17, 18×19, 20×22, 21×23, 24×27 mm	1	2085

210-..., 210A-...

HEXAGON TUBULAR BOX SPANNER

- ▶ for use with tommy bar ELORA-No. 211 or stepped tommy bar ELORA-No. 212-1
- ▶ hollow shaft made of seamless hardened steel tube, hardened
- ▶ matt chrome plated
- ▶ tommy bars are not included
- ▶ ELORA-Tempering steel C 45 / 1.0503
- ▶ according to DIN 896, Form B, ISO 2236, ISO 1085



mm

AF^m

Code	Number	l/mm ┌	Hole-Ø mm	Pieces ☞	Weight/g ⚖	Code	Number	l/mm ┌	Hole-Ø mm	Pieces ☞	Weight/g ⚖
0210004051000	210-4x5	100	5,0	12	16	0210113151000	210A-1/4x9/32	100	6,5	12	27
0210006071000	210-6x7	100	5,5	12	27	0210117191000	210A-5/16x3/8	120	6,5	12	46
0210007081000	210-7x8	105	6,5	12	36	0210119211000	210A-3/8x7/16	120	6,5	12	46
0210008091000	210-8x9	105	6,5	12	36	0210121231000	210A-7/16x1/2	140	8,5	6	70
0210008101000	210-8x10	120	6,5	12	46	0210123241000	210A-1/2x9/16	140	8,5	6	76
0210009101000	210-9x10	120	6,5	12	46	0210124261000	210A-9/16x5/8	150	8,5	6	122
0210009111000	210-9x11	120	6,5	12	46	0210127281000	210A-11/16x3/4	160	12,5	6	205
0210010111000	210-10x11	120	6,5	12	50	0210128311000	210A-3/4x7/8	167	12,5	6	235
0210010121000	210-10x12	140	8,5	6	68	0210130311000	210A-13/16x7/8	170	12,5	6	235
0210010131000	210-10x13	140	8,5	6	70	0210131321000	210A-7/8x15/16	187	14,5	3	229
0210010141000	210-10x14	140	8,5	6	70	0210132341000	210A-15/16x1	190	14,5	3	300
0210011131000	210-11x13	140	8,5	6	70	0210135381000	210A-1.1/16x1.1/4	200	16,5	3	400
0210011141000	210-11x14	140	8,5	6	70						
0210012131000	210-12x13	140	8,5	6	72						
0210012141000	210-12x14	140	8,5	6	76						
0210013141000	210-13x14	140	8,5	6	76						
0210013151000	210-13x15	140	8,5	6	82						
0210013161000	210-13x16	150	10,5	6	120						
0210013171000	210-13x17	150	10,5	6	122						
0210014151000	210-14x15	140	8,5	6	82						
0210014171000	210-14x17	150	10,5	6	122						
0210016171000	210-16x17	150	10,5	6	126						
0210016181000	210-16x18	160	10,5	6	205						
0210017191000	210-17x19	160	12,5	6	205						
0210017221000	210-17x22	170	12,5	6	200						
0210018191000	210-18x19	160	12,5	6	205						
0210018211000	210-18x21	160	12,5	6	210						
0210019221000	210-19x22	170	12,5	6	235						
0210019241000	210-19x24	190	14,5	3	275						
0210020221000	210-20x22	170	12,5	6	235						
0210021231000	210-21x23	170	12,5	3	250						
0210021241000	210-21x24	190	14,5	3	280						
0210022241000	210-22x24	190	14,5	3	280						
0210022271000	210-22x27	190	14,5	3	305						
0210024261000	210-24x26	190	14,5	3	300						
0210024271000	210-24x27	190	14,5	3	300						
0210024301000	210-24x30	200	16,5	3	380						
0210025281000	210-25x28	200	14,5	3	340						
0210027291000	210-27x29	200	16,5	3	390						
0210027301000	210-27x30	200	16,5	3	380						
0210027321000	210-27x32	200	16,5	3	400						
0210028321000	210-28x32	200	16,5	3	375						
0210030321000	210-30x32	200	16,5	3	395						
0210030361000	210-30x36	220	18,5	1	592						
0210032361000	210-32x36	220	18,5	1	586						
0210036411000	210-36x41	220	18,5	1	731						
0210038421000	210-38x42	230	18,5	1	813						
0210041461000	210-41x46	240	21,0	1	908						
0210046501000	210-46x50	240	21,0	1	928						
0210050551000	210-50x55	240	21,0	1	1000						
0210055601000	210-55x60	240	21,0	1	2110						

210S...M, 210S...AF

HEXAGON TUBULAR BOX SPANNER-SET

- carton box packed
- for use with tommy bar ELORA-No. 211 or stepped tommy bar ELORA-No. 212-1
- hollow shaft made of seamless steel tube
- hardened
- matt chrome plated
- tommy bars are not included
- ELORA-Tempering steel C 45 / 1.0503
- according to DIN 896, Form B, ISO 2236, ISO 1085



02



Code	Number	Contents	Pieces	Weight/g	Code	Number	Contents	Pieces	Weight/g
0210500601000	210S 6M	210-6x7, 8x9, 10x11, 12x13, 14x15, 16x17 mm	1	440	0210600601000	210S 6AF	210A- 5/16x3/8, 7/16x1/2, 9/16x5/8, 11/16x3/4, 13/16x7/8, 15/16x1 AF	1	1008
0210500801000	210S 8M	210- 6x7, 8x9, 10x11, 12x13, 14x15, 16x17, 18x19, 20x22 mm	1	835	0210600801000	210S 8AF	210A- 1/4x9/32, 5/16x3/8, 7/16x1/2, 9/16x5/8, 11/16x3/4, 13/16x7/8, 15/16x1, 1.1/16x1.1/4 AF	1	1460
0210501001000	210S 10M	210- 6x7, 8x9, 10x11, 12x13, 14x15, 16x17, 18x19, 20x22, 21x23, 24x27 mm	1	1470					
0210501201000	210S 12M	210- 6x7, 8x9, 10x11, 12x13, 14x15, 16x17, 18x19, 20x22, 21x23, 24x27, 25x28, 30x32 mm	1	2080					
0210501401000	210S 14M	210- 6x7, 8x9, 10x11, 12x13, 14x15, 16x17, 18x19, 20x22, 21x23, 24x27, 25x28, 30x32, 36x41, 46x50 mm	1	3780					

211-...

TOMMY BAR

- for hexagon tubular box spanners No. 210 and 217
- hardened, chrome plated
- ELORA-Chrome-Vanadium 31CrV3 / 1.2208
- according to DIN 900, Form A



Code	Number	for sizes mm	for sizes AF	l/mm	Diameter Ø mm	Pieces	Weight/g
0211000051000	211-5	4 - 5	1/4 - 9/32	125	5	12	20
0211000061000	211-6	6 - 11	5/16 - 7/16	160	6	6	35
0211000081000	211-8	12 - 15	15/32 - 19/32	180	8	6	71
0211000101000	211-10	16 - 17	5/8 - 11/16	200	10	6	123
0211000121000	211-12	18 - 22	3/4 - 7/8	250	12	3	222
0211000141000	211-14	23 - 27	15/16 - 1	320	14	3	386
0211000161000	211-16	24 - 32	1.1/16 - 1.1/4	400	16	3	631
0211000181000	211-18	30 - 41		500	18	3	1000
0211000201000	211-20	41 - 60		630	20	3	1553

212-...

STEPPED TOMMY BAR

- for hex. tubular box spanners ELORA-No. 206, 210 and 217
- hardened, chrome plated
- ELORA-Chrome-Vanadium 31CrV3 / 1.2208
- according to DIN 900, Form C



Code	Number	for sizes mm	for sizes AF	Diameter Ø mm	l/mm	Pieces	Weight/g
0212000000000	212-1	6 - 27	5/16 - 1	6 - 8 - 10 - 12 - 14	250	6	230
0212000020000	212-2	6 - 19	5/16 - 3/4	3,2 - 4,3 - 5,3 - 6,9 - 7,9	250	6	230
0212000030000	212-3	20 - 27	5/32 - 1.1/4	6,9 - 7,9 - 9,8 - 11,8 - 12,8	250	6	230

214-...

HEXAGON NUT DRIVER WITH T-HANDLE

- short and long type
- plastic T-handle with suspension hole
- matt chrome plated
- ELORA-Chrome-Vanadium 31CrV3 / 1.2208

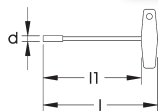

Code	Number	d mm	l1 mm	l/mm	Pieces	Weight/g
0214005121000	214-5,5-125	9	125	160	6	68
0214005231000	214-5,5-230	8	230	265	6	68
0214006121000	214-6-125	9	125	160	6	70
0214006231000	214-6-230	9	230	265	6	104
0214007121000	214-7-125	11	125	160	6	104
0214007231000	214-7-230	11	230	265	6	125
0214008121000	214-8-125	12	125	160	6	104
0214008231000	214-8-230	12	230	265	6	125
0214008351000	214-8-350	12	350	385	6	170
0214009121000	214-9-125	13	125	160	6	110
0214009231000	214-9-230	13	230	265	6	140
0214009351000	214-9-350	13	350	385	6	155
0214010121000	214-10-125	14	125	160	6	104
0214010231000	214-10-230	14	230	265	6	140

Code	Number	d mm	l1 mm	l/mm	Pieces	Weight/g
0214010351000	214-10-350	14	350	385	6	215
0214011121000	214-11-125	16	125	160	6	120
0214011231000	214-11-230	16	230	265	6	170
0214011351000	214-11-350	16	350	385	6	215
0214012121000	214-12-125	17	125	160	6	130
0214012231000	214-12-230	17	230	265	6	170
0214012351000	214-12-350	17	350	385	6	215
0214013121000	214-13-125	18	125	160	6	130
0214013231000	214-13-230	18	230	265	6	180
0214013351000	214-13-350	18	350	385	6	220
0214014121000	214-14-125	19	125	160	6	140
0214014231000	214-14-230	19	230	265	6	180
0214014351000	214-14-350	20	350	385	6	220

236-LM-...

JOINT SOCKET WRENCH WITH T-HANDLE

- for work in awkward areas
- long version
- fixed mounted socket with cardan
- 3/8" square drive on the T-handle side
- chrome plated
- Chrome-Vanadium 31CrV3 / 1.2208

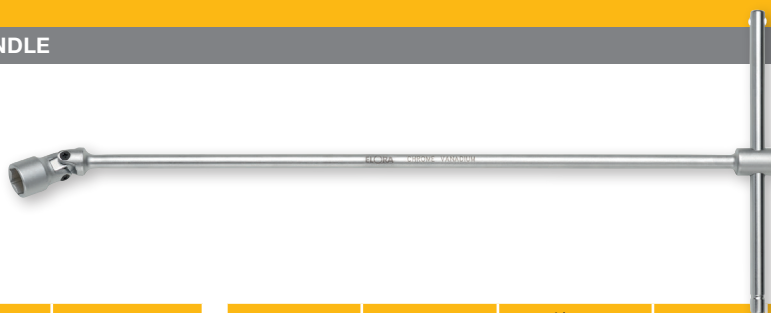

Code	Number	l/mm	Pieces	Weight/g
0236000092000	236-LM9	390	4	400
0236000102000	236-LM10	500	4	500
0236000112000	236-LM11	500	4	500
0236000122000	236-LM12	500	4	500
0236000132000	236-LM13	500	4	500

Code	Number	l/mm	Pieces	Weight/g
0236000142000	236-LM14	500	4	500
0236000152000	236-LM15	500	4	500
0236000162000	236-LM16	500	4	500
0236000172000	236-LM17	500	4	500
0236000182000	236-LM18	500	4	500
0236000192000	236-LM19	500	4	500

236-LMG-...

JOINT SOCKET WRENCH WITH MAGNET AND T-HANDLE

- for work in awkward areas
- long version
- fix mounted socket with magnet and cardan
- chrome plated
- Chrome-Vanadium 31CrV3 / 1.2208

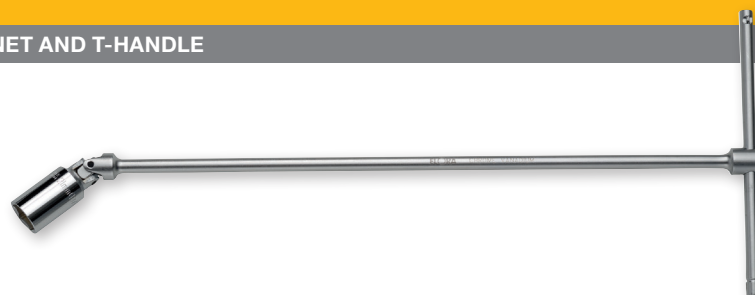

Code	Number	l/mm	Pieces	Weight/g
0236000141000	236-LMG14	485	4	525
0236000161000	236-LMG16	485	4	525

Code	Number	l/mm	Pieces	Weight/g
0236000181000	236-LMG18	485	4	525

213-...

HEXAGON NUT DRIVER, FLEXIBLE

- nonslip QUATROLIT®-2K-handle
- with suspension hole
- limited torque!
- chrome plated

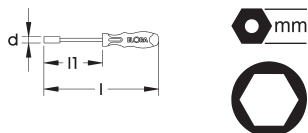

Code	Number	d mm	l1 mm	l/mm	Pieces	Weight/g
0213020050000	213-5	8,0	150	250	6	150
0213020060000	213-6	9,8	150	250	6	150
0213020070000	213-7	10,0	150	250	6	150
0213020080000	213-8	12,0	150	250	6	150
0213020100000	213-10	14,0	150	275	6	270

215-...

HEXAGON NUT DRIVER, SHORT

- short version
- nonslip QUATROLIT®-2K-handle
- with suspension hole
- matt chrome plated
- ELORA-Chrome-Vanadium 31CrV3 / 1.2208

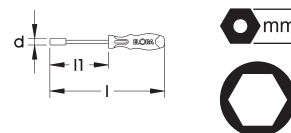

Code	Number	d mm	l1 mm	l/mm	Pieces	Weight/g
0215000037000	215-3	6,0	55	140	6	55
0215000047000	215-4	7,0	55	140	6	55
02150000457000	215-4,5	7,0	55	140	6	55
0215000057000	215-5	8,0	55	140	6	55
02150000557000	215-5,5	8,1	55	140	6	58
0215000067000	215-6	9,0	55	140	6	58
0215000087000	215-8	12,0	55	150	6	84
0215000097000	215-9	13,0	55	150	6	86
0215000107000	215-10	13,0	55	150	6	88
0215000117000	215-11	16,0	55	160	6	116
0215000127000	215-12	17,0	55	160	6	118
0215000137000	215-13	18,0	55	160	6	130
0215000147000	215-14	20,0	55	160	6	130

216-..., 216A-...

HEXAGON NUT DRIVER, LONG

- long version
- nonslip QUATROLIT®-2K-handle
- with suspension hole
- matt chrome plated
- ELORA-Chrome-Vanadium 31CrV3 / 1.2208
- according to DIN 3125, ISO 2725-1

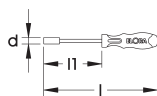

Code	Number	d mm	l1 mm	l/mm	Pieces	Weight/g
0216000032000	216-3	6,0	125	210	6	65
0216000042000	216-4	7,0	125	210	6	65
02160000452000	216-4,5	7,0	125	210	6	65
0216000052000	216-5	8,0	125	210	6	65
02160000552000	216-5,5	8,1	125	210	6	65
0216000062000	216-6	9,0	125	210	6	75
0216000072000	216-7	11,0	125	220	6	98
0216000082000	216-8	12,0	125	220	6	114
0216000092000	216-9	13,0	125	220	6	130
0216000102000	216-10	14,0	125	220	6	130
0216000112000	216-11	16,0	125	230	6	160
0216000122000	216-12	17,0	125	230	6	180
0216000132000	216-13	18,0	125	230	6	190
0216000142000	216-14	19,0	125	230	6	190

Code	Number	d mm	l1 mm	l/mm	Pieces	Weight/g
0216100062000	216A-1/8	5,0	125	210	6	65
0216100082000	216A-5/32	7,0	125	210	6	65
0216100092000	216A-3/16	8,0	125	220	6	65
0216100112000	216A-7/32	9,0	125	210	6	98
0216100132000	216A-1/4	10,0	125	210	6	98
0216100152000	216A-9/32	11,0	125	220	6	114
0216100172000	216A-5/16	12,0	125	220	6	114
0216100182000	216A-11/32	13,0	125	220	6	130
0216100192000	216A-3/8	14,0	125	220	6	130
0216100212000	216A-7/16	16,0	125	230	6	160
0216100232000	216A-1/2	18,0	125	230	6	190
0216100242000	216A-9/16	20,0	125	230	6	190

217-...

TUBULAR BOX SPANNER WITH HANDLE

- long version
- with drilled hole for tommy bars
- for use with tommy bars ELORA-No. 211
- from size 8 mm also with stepped tommy ELORA-No. 212-1
- with QUATROLIT®-handle
- with suspension hole
- seamless steel tube, hardened
- matt chrome plated
- Chrome-Vanadium 31CrV3 / 1.2208

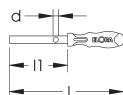
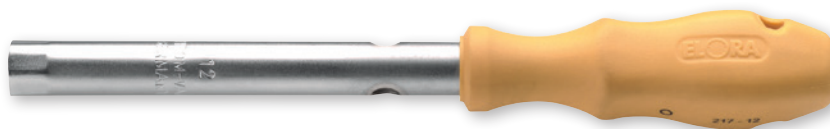

Code	Number	d mm	l1 mm	l/mm	Pieces	Weight/g
0217000031000	217-3	without hole	125	220	6	56
0217000041000	217-4	without hole	125	220	6	62
0217000451000	217-4,5	without hole	125	220	6	56
0217000051000	217-5	without hole	125	220	6	60
0217000551000	217-5,5	without hole	125	210	6	92
0217000061000	217-6	6,2	125	220	6	104
0217000071000	217-7	6,2	125	220	6	104
0217000081000	217-8	6,2	125	220	6	104
0217000091000	217-9	6,2	125	220	6	112
0217000101000	217-10	6,2	125	230	6	112
0217000111000	217-11	6,2	125	230	6	116
0217000121000	217-12	8,2	125	230	6	155
0217000131000	217-13	8,2	125	230	6	155
0217000141000	217-14	8,2	125	230	6	160
0217000151000	217-15	8,2	125	240	6	165
0217000161000	217-16	8,2	125	240	6	210
0217000171000	217-17	8,2	125	240	6	210

70-2

MULTI FITTING KEY 9 IN 1

- for all usual technical shut-off systems
- 1 tool for 9 applications
- 8 different master cabinet shut-off systems and 5 mm square for radiator valves
- flat construction due to space saving swivel mechanism
- square locking: 5, 6, 7-8, 9-10 mm
- three-edged locking: 7, 8-9, 10-11 mm
- two-way-key 3-5 mm and half-moon locking 6 mm
- securing chain with snap-hook
- dimensions: 95 x 95 mm
- zinc die-casting

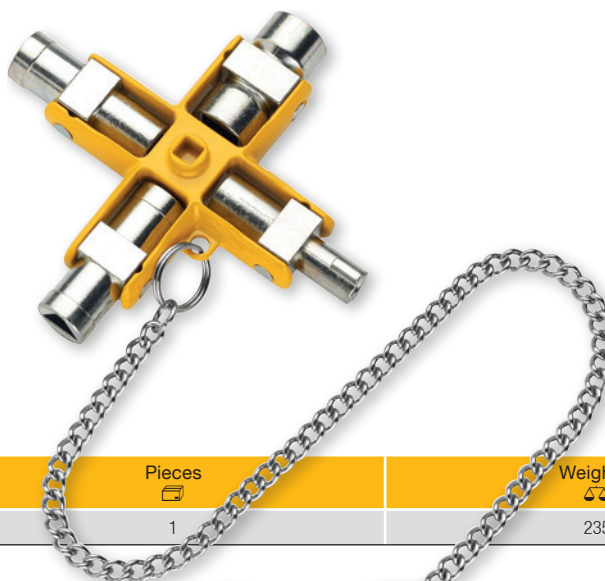

Code	Number	Pieces	Weight/g
0070000021000	70-2	1	235

70-1

MULTI FITTING KEY

- female square 5, 6, 7-8 mm
- female three-square 8-9 mm
- multi fitting key: 3-5 mm
- 5 mm square for radiator valves
- body with 1/4" bit holder with magnet
- dimensions: 97 x 25 mm
- zinc die-casting



Code	Number	Pieces	Weight/g
0070000011000	70-1	1	80

70-3

MULTI FITTING KEY ELECTRICAL

- for closings of: pneumatic and hydraulic systems
- magnetic valves in automobile- and machinery sector
- magnetic valves of oil heating
- contactless detection of permanent magnets
- contactless voltage field sensor
- implemented magnetic field sensor
- dimensions: approx.: 158 x 28 mm
- female square 5, 6, 7-8 mm
- female three-square 9 mm
- 5 mm square for radiator valves
- two-way-key 3-5 mm
- magnetic bit adaptor 1/4", supplied with one bit PH 2
- screwdriver function with retaining clip
- zinc die-casting



Code	Number	Pieces	Weight/g
0070000031000	70-3	1	136

ELORA



SOCKET ASSORTMENTS

Socket Assortments 1/4" _____	Page 128
Socket Assortments 3/8" _____	Page 137
Socket Assortments 1/2" _____	Page 149
Socket Assortments 3/4" _____	Page 182
Socket Assortments 1" _____	Page 192



The high-performance CNC turning centre, our product developer and our “rotation designer” are our 3 specialists for many ELORA stars, such as our reversible ratchets.

Whether you work in precision mechanics or heavy industry, hardly any production facility or workshop today can get by without socket wrenches. And the range of sockets and socket wrenches available from ELORA reflects this broad spectrum of applications. Tradesmen and women appreciate the absolutely dependable quality and the excellent design which ensure long tool lifetimes even under heavy loads. To make certain that this precision tool meets all the requirements expected in industrial environments, a series of production steps are required, as we explain here.

You will be impressed by the amount of effort our tool experts put into every tool we make up to the point where it is ready for worldwide shipment and sold to a satisfied customer. This applies to all our products – whether it is a single tool or a complete, carefully compiled tool set.

As with all ELORA product families, we place great store by ensuring consistently high product quality, which is why the tight quality controls we apply after every operation have been standard procedure here for some time.

You can expect really tough ratchets that will never let you down – a result of our hand-picked raw materials and sophisticated manufacturing processes. And, to match, we have numerous different sockets and types of sockets. Our impressive product range includes TORX®, multipoint-head, internal hex drive, slotted and Phillips / Pozidriv – you get exactly what you need.

In conclusion – when you buy an ELORA ratchet, you are buying a particularly high-quality tool. Included in the price is the satisfaction of knowing that you have bought a piece of high-grade German engineering – workmanship that is worth every cent.



The inherent qualities of ELORA ratchets are also very impressive. The fine-toothed precision-made gearing that ensures concentricity and maximum functionality. The individual production steps leading up to the “marriage” of outer body and inner mechanisms all require extensive know-how coupled with an enthusiastic attention to detail.

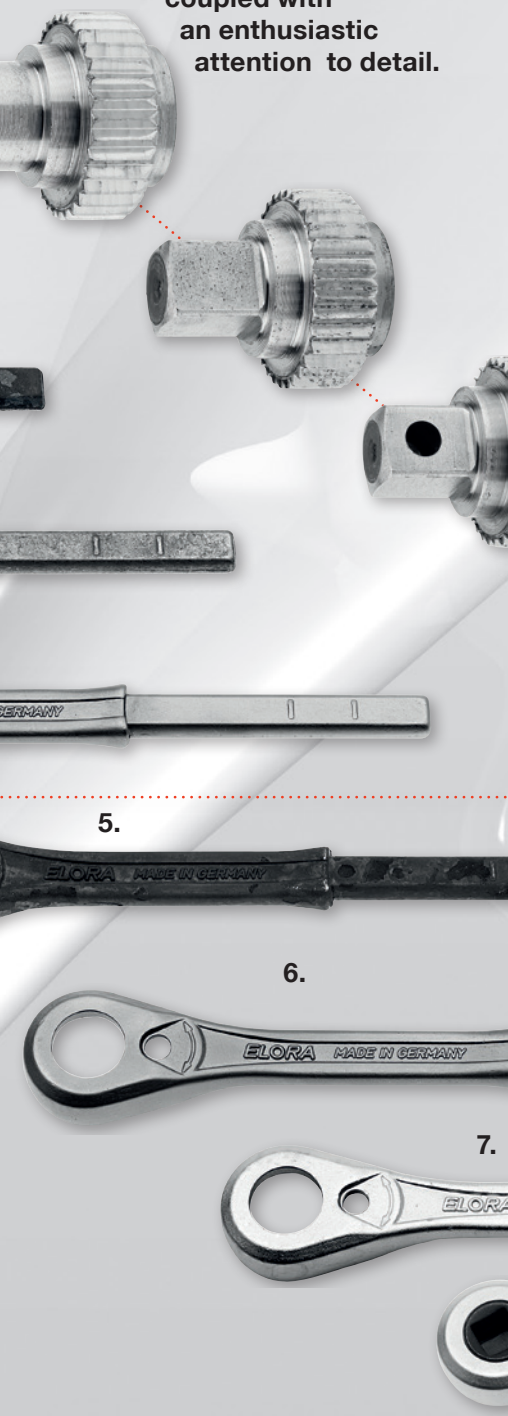

1. Blanking

The starting material is high-grade ELORA chrome vanadium 31 CrV3/1.2208.

2. Hot forging & flash removal

- a. The cropped blank is heated in a furnace to the correct forging temperature and then drop forged in this hot state using high press forces.
- b. Following this, the flash is then removed using flash-removal presses.

3. Grinding & vibro-deburring

The subsequent grinding process ensures the tool has a smooth outside surface. Any sharp edges and flash still remaining are then removed by vibro-deburring.

4. CNC machining

The internal shaping of the ratchet head is machined exactly to size in a machining centre.

5. Hardening and tempering

This special heat treatment ensures the longest possible service lifetimes. The tool's tensile strength is provided by precise hardening to a given temperature and the high level of ductility by the tempering process.

6. Sand blasting

To make sure the ratchet has a matt, non-slip surface, we sand-blast it.

7. Electroplating

The surface is given durable anti-corrosion protection and a high-quality satin-finish appearance.

8. “Marriage” & final assembly

This process involves bringing together the body and internal mechanisms. The handle, internal mechanisms and cover are fitted. The tool's functionality is thoroughly checked.

5.

6.

7.

8.

03

If ELORA customers want to get the full benefit of an ELORA ratchet, they really need sockets of the same high quality. As you would expect, the manufacture of these sockets is subject to the same stringent quality requirements and ELORA sockets are also hot forged.

This creates a microscopic fibre-like structure in the metal with no interruptions (in contrast to cold-formed tools) which always runs parallel to the outer shape. Unwanted stresses in the tool are thus kept to an absolute minimum. At the same time, this increases the tool's durability and tensile strength by a considerable degree – these are product benefits that pay for themselves, especially when you are applying full loadings, and enable long service lives.

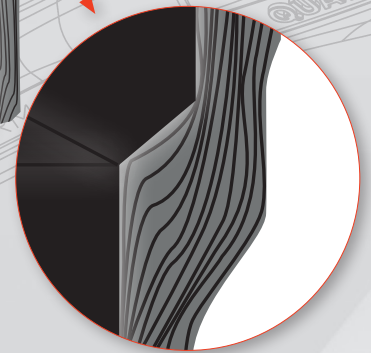
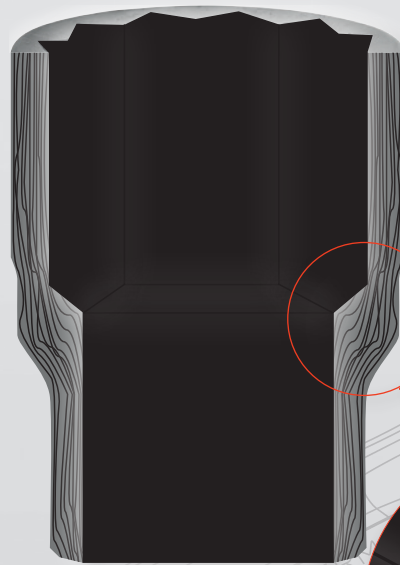

One advantage of hot forging: the uninterrupted fibre-like structure

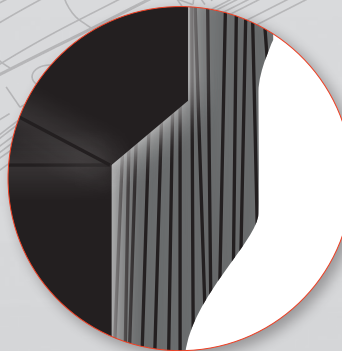

The disadvantage of cold-forming: interrupted fibres



This ELORA product family contains a wide range of sockets designed for all sectors of industry and the trades. Input and output drives for many different types of sockets. All the standard sizes you would expect. Separately or in sets. In robust, protective metal cases or ready for use in exactly cut, easy-to-use ELORA OMS modules.



The production process for ELORA sockets is both costly and complex

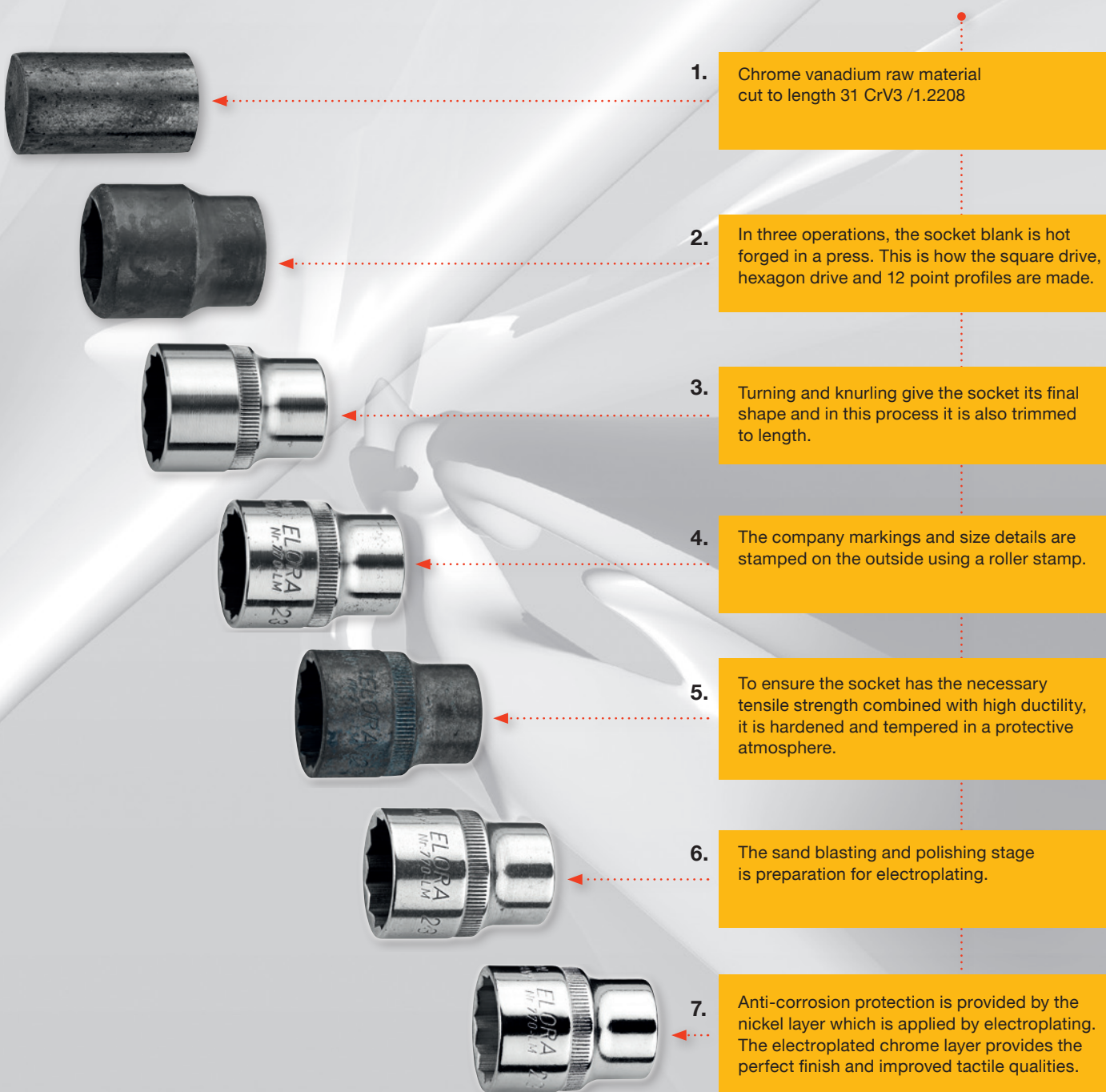

1450-1D

REVERSIBLE RATCHET 1/4", FINE TOOTH

- with small, slim head
- gear wheel with safety locking and quick release button
- smallest possible swivel angle 5°
- nonslip QUATROLIT®-2C-handle
- with suspension hole
- matt chrome-plated
- ELORA-Chrome-Vanadium 31CrV3 / 1.2208
- male square according to DIN 3120-A 6,3, ISO 1174, with ball locking device
- according to DIN 3122, ISO 3315



6,3

1/4"

Code	Number	l/mm	Pieces	Weight/g
1450000012200	1450-1D	145	1	104
1450000012003	1450-E1D	Repair Kit	1	20

1450-1UN

REVERSIBLE RATCHET 1/4", FINE TOOTH

- with small, round head
- forged, fine toothed wheel with grippy metal switching disk
- smallest possible swivel angle 5°
- nonslip QUATROLIT®-2C-handle
- with suspension hole
- matt chrome-plated
- ELORA-Chrome-Vanadium 31CrV3 / 1.2208
- male square according to DIN 3120-A 6,3, ISO 1174, with ball locking device
- according to DIN 3122, ISO 3315



6,3

1/4"

Code	Number	l/mm	Pieces	Weight/g
1450000013900	1450-1UN	145	1	121
1450000012012	1450-E1UN	Repair Kit	1	35

1450-2ZI

PUSH THROUGH RATCHET 1/4"

- extremely rugged ratchet with round head
- forged gear wheel with push through square coupler
- smallest possible swivel angle 18°
- plastic handle
- matt chrome-plated
- ELORA-Chrome-Vanadium 31 CrV 3 / 1.2208
- square according to DIN 3120-A 6,3, ISO 1174, with ball locking device
- according to DIN 3122, ISO 3315

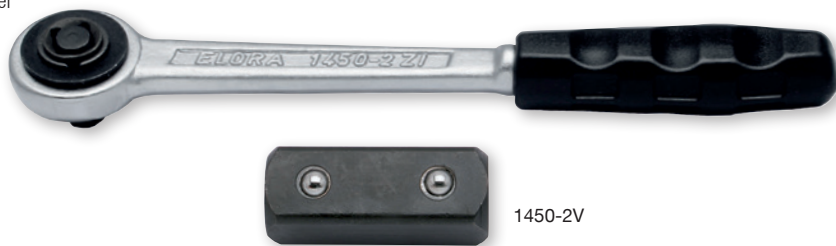

6,3

1/4"

Code	Number	l/mm	Pieces	Weight/g
1450000022000	1450-2ZI	140	1	89
1450000022001	1450-E2ZI	Repair Kit	1	20
1450000022002	1450-2V	21	1	8

You will find the matching socket converter 1/4" on page no. 133



1455-M..., 1455A-...

SOCKET 1/4", HEXAGON

- matt chrome-plated
- knurled
- ELORA-Chrome-Vanadium 31CrV3 / 1.2208
- female square according to DIN 3120-C 6,3, ISO 1174, with ball retaining groove
- according to DIN 3124, ISO 2725-1

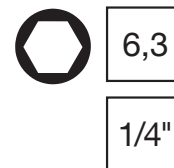

Code	Number	l/mm	Pieces	Weight/g
1455000352000	1455-M 3,5	25	12	9
1455000042000	1455-M 4	25	12	9
1455000452000	1455-M 4,5	25	12	10
1455000052000	1455-M 5	25	12	10
1455000552000	1455-M 5,5	25	12	10
1455000062000	1455-M 6	25	12	10
1455000072000	1455-M 7	25	12	11
1455000082000	1455-M 8	25	12	12
1455000092000	1455-M 9	25	12	14
1455000102000	1455-M 10	25	12	18
1455000112000	1455-M 11	25	12	23
1455000122000	1455-M 12	25	12	24
1455000132000	1455-M 13	25	12	24
1455000142000	1455-M 14	25	12	28

Code	Number	l/mm	Pieces	Weight/g
1455100082000	1455A-5/32	25	12	9
1455100092000	1455A-3/16	25	12	10
1455100112000	1455A-7/32	25	12	10
1455100132000	1455A-1/4	25	12	10
1455100152000	1455A-9/32	25	12	11
1455100172000	1455A-5/16	25	12	12
1455100182000	1455A-11/32	25	12	14
1455100192000	1455A-3/8	25	12	18
1455100212000	1455A-7/16	25	12	23
1455100232000	1455A-1/2	25	12	24
1455100242000	1455A-9/16	25	12	28

03

1455-T...

SOCKET 1/4", HEXAGON, EXTRA DEEP

- matt chrome-plated
- knurled
- ELORA-Chrome-Vanadium 31CrV3 / 1.2208
- female square according to DIN 3120-C 6,3, ISO 1174, with ball retaining groove
- according to DIN 3124, ISO 2725-1

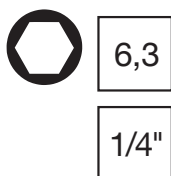

Code	Number	l/mm	Pieces	Weight/g
1455050402000	1455-T 4	50	6	14
1455050452000	1455-T 4,5	50	6	14
1455050502000	1455-T 5	50	6	15
1455050552000	1455-T 5,5	50	6	16
1455050602000	1455-T 6	50	6	17
1455050702000	1455-T 7	50	6	22
1455050802000	1455-T 8	50	6	25
1455050902000	1455-T 9	50	6	29
1455051002000	1455-T 10	50	6	33
1455051102000	1455-T 11	50	6	46
1455051202000	1455-T 12	50	6	51
1455051302000	1455-T 13	50	6	55
1455051402000	1455-T 14	50	6	72

1455-TXE...

SOCKET 1/4"

- for outside TORX® screws
- matt chrome-plated
- knurled
- ELORA-Chrome-Vanadium 31CrV3 / 1.2208
- female square according to DIN 3120-C 6,3, ISO 1174, with ball retaining groove
- TORX® = reg. trademark of Acument Intellectual Properties, LLC. USA

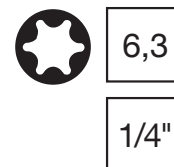

Code	Number	l/mm	l/mm	Pieces	Weight/g
1455060042000	1455-TXE 4	3,86	25	12	12
1455060052000	1455-TXE 5	4,75	25	12	12
1455060062000	1455-TXE 6	5,74	25	12	14
1455060072000	1455-TXE 7	6,22	25	12	14
1455060082000	1455-TXE 8	7,52	25	12	15
1455060102000	1455-TXE 10	9,42	25	12	18
1455060112000	1455-TXE 11	9,98	25	12	18

1455-IS...

SCREWDRIVER SOCKET 1/4"

- for plain slotted screws
- matt chrome-plated
- knurled
- ELORA-Chrome-Vanadium 31CrV3 / 1.2208
- female square according to DIN 3120-C 6,3, ISO 1174, with ball retaining groove
- with manganese-phosphated blade
- tips according to DIN ISO 2380-1 Form B

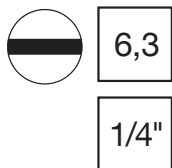

Code	Number	Blade Size mm	l/mm	Pieces	Weight/g
1455020402000	1455-IS 4	0,8 x 4,0	25	12	10
1455020552000	1455-IS 5,5	1,0 x 5,5	25	12	11
1455020652000	1455-IS 6,5	1,2 x 6,5	25	12	11
1455020802000	1455-IS 8	1,6 x 8,0	25	12	11

1455-PH...

SCREWDRIVER SOCKET 1/4"

- for cross slotted screws
- matt chrome-plated
- knurled
- ELORA-Chrome-Vanadium 31CrV3 / 1.2208
- female square according to DIN 3120-C 6,3, ISO 1174, with ball retaining groove
- with manganese-phosphated blade
- tips according to DIN ISO 8764-1 PH

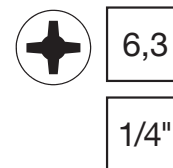

Code	Number	l/mm	Pieces	Weight/g
1455021012000	1455-PH 1	28	12	11
1455021022000	1455-PH 2	28	12	11
1455021032000	1455-PH 3	28	12	12
1455021042000	1455-PH 4	28	12	13

1455-PZ...

SCREWDRIVER SOCKET 1/4"

- for cross slotted screws
- matt chrome-plated
- knurled
- ELORA-Chrome-Vanadium 31CrV3 / 1.2208
- female square according to DIN 3120-C 6,3, ISO 1174, with ball retaining groove
- with manganese-phosphated blade
- tips according to DIN ISO 8764-1 PZ

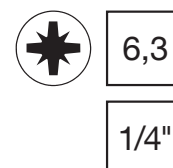

Code	Number	l/mm	Pieces	Weight/g
1455022012000	1455-PZ 1	28	12	10
1455022022000	1455-PZ 2	28	12	11
1455022032000	1455-PZ 3	28	12	12

1455-IN..., 1455-INA...

SCREWDRIVER SOCKET 1/4"

- for inside hexagon screws
- matt chrome-plated
- knurled
- ELORA-Chrome-Vanadium 31CrV3 / 1.2208
- with manganese-phosphated male hexagon
- female square according to DIN 3120-C 6,3, ISO 1174, with ball retaining groove
- according to DIN 7422

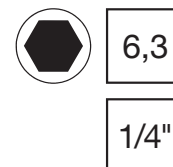

Code	Number	l/mm	Pieces	Weight/g	Code	Number	l/mm	Pieces	Weight/g
1455010022005	1455-IN 2,5	25	12	10	1455110062000	1455-IN 1/8	25	12	10
1455010032000	1455-IN 3	25	12	10	1455110082000	1455-IN 5/32	25	12	10
1455010042000	1455-IN 4	25	12	10	1455110092000	1455-IN 3/16	25	12	11
1455010052000	1455-IN 5	25	12	11	1455110112000	1455-IN 7/32	25	12	11
1455010062000	1455-IN 6	25	12	11	1455110132000	1455-IN 1/4	25	12	11
1455010072000	1455-IN 7	25	12	12	1455110172000	1455-IN 5/16	25	12	14
1455010082000	1455-IN 8	25	12	14					

3243-TX...

SCREWDRIVER SOCKET 1/4"

- for inside TORX® screws
- matt chrome-plated
- knurled
- with manganese-phosphated blade
- ELORA-Chrome-Vanadium 31CrV3 / 1.2208
- female square according to DIN 3120-C 6,3, ISO 1174, with ball retaining groove
- TORX® = reg. trademark of Acument Intellectual Properties, LLC. USA



6,3

1/4"



3243-TTX...

SCREWDRIVER SOCKET 1/4"

- for inside TORX® safety screws
- matt chrome-plated
- knurled
- with manganese-phosphated blade with bore hole
- ELORA-Chrome-Vanadium 31CrV3 / 1.2208
- female square according to DIN 3120-C 6,3, ISO 1174, with ball retaining groove
- TORX® = reg. trademark of Acument Intellectual Properties, LLC. USA



6,3

1/4"



Code	Number	★ mm	l/mm	Pieces ☞	Weight/g ⚖
3243000082000	3243-TX 8	2,31	28	6	7
3243000092000	3243-TX 9	2,50	28	6	7
3243000102000	3243-TX 10	2,74	28	6	8
3243000152000	3243-TX 15	3,27	28	6	8
3243000202000	3243-TX 20	3,86	28	6	8
3243000252000	3243-TX 25	4,43	28	6	8
3243000272000	3243-TX 27	4,99	28	6	9
3243000302000	3243-TX 30	5,52	28	6	9
3243000402000	3243-TX 40	6,65	28	6	10

Code	Number	★ mm	l/mm	Pieces ☞	Weight/g ⚖
3243010082000	3243-TTX 8	2,31	28	6	7
3243010092000	3243-TTX 9	2,50	28	6	7
3243010102000	3243-TTX 10	2,74	28	6	8
3243010152000	3243-TTX 15	3,27	28	6	8
3243010202000	3243-TTX 20	3,86	28	6	8
3243010252000	3243-TTX 25	4,43	28	6	8
3243010272000	3243-TTX 27	4,99	28	6	9
3243010302000	3243-TTX 30	5,52	28	6	9
3243010402000	3243-TTX 40	6,65	28	6	10

1455-KL, 1455-MKL

SOCKET RAIL 1/4"

1455-KL:

- 15 shiftable socket clips
- two holes allow permanent mounting
- chrome-plated, polished

1455-MKL:

- 11 shiftable socket clips
- strong magnet enables firm mounting
- black coated



6,3

1/4"

Code	Number	l/mm	Pieces ☞	Weight/g ⚖
0000914146000	1455-KL	414	1	67
0000914146001	1455-MKL	200	1	122

1455-SB

PLASTIC HOLDER 1/4"

- appropriate for sockets nominal size 6,3 (1/4") and operation tools with female square



6,3

1/4"

Code	Number	Pieces ☞	Weight/g ⚖
0000700147000	1455-SB	1	10

1450-3

SPINNER HANDLE 1/4"

- ▶ nonslip QUATROLIT®-2C-handle
- ▶ with suspension hole
- ▶ matt chrome-plated
- ▶ ELORA-Chrome-Vanadium 31CrV3 / 1.2208
- ▶ male square according to DIN 3120-A 6,3, ISO 1174, with ball locking device
- ▶ according to DIN 3122, ISO 3315



6,3

1/4"

Code	Number	l/mm	Pieces	Weight/g
1450000032000	1450-3	150	6	92

1450-4

SLIDING T-BAR 1/4"

- ▶ matt chrome-plated
- ▶ ELORA-Chrome-Vanadium 31CrV3 / 1.2208
- ▶ male square according to DIN 3120-A 6,3, ISO 1174, with ball locking device
- ▶ according to DIN 3122, ISO 3315



6,3

1/4"

Code	Number	l/mm	Pieces	Weight/g
1450000042000	1450-4	115	6	48

1450-7

FLEXIBLE HANDLE 1/4"

- ▶ matt chrome-plated
- ▶ ELORA-Chrome-Vanadium 31CrV3 / 1.2208
- ▶ male square according to DIN 3120-A 6,3, ISO 1174, with ball locking device
- ▶ according to DIN 3122, ISO 3315



6,3

1/4"

Code	Number	l/mm	Pieces	Weight/g
1450000072000	1450-7	150	6	96

1450-...

EXTENSION BAR 1/4"

- ▶ matt chrome-plated
- ▶ ELORA-Chrome-Vanadium 31CrV3 / 1.2208
- ▶ square drive according to DIN 3120, ISO 1174, with ball locking device resp. with ball retaining groove
- ▶ according to DIN 3123, ISO 3316

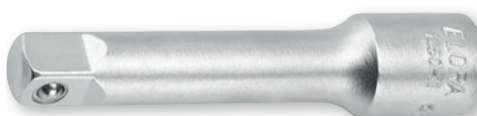

6,3

1/4"

Code	Number	l/mm	Pieces	Weight/g
1450000112000	1450-11	50	6	24
1450000052000	1450-5	100	6	42
1450000122000	1450-12	150	6	64

1450-6

FLEXIBLE EXTENSION BAR 1/4"

- ▶ matt chrome-plated
- ▶ ELORA-Chrome-Vanadium 31CrV3 / 1.2208
- ▶ square drive according to DIN 3120, ISO 1174, with ball locking device resp. with ball retaining groove



6,3

1/4"

Code	Number	l/mm	Pieces	Weight/g
1450000062000	1450-6	125	6	50

1450-8

UNIVERSAL JOINT 1/4"

- matt chrome-plated
- ELORA-Chrome-Vanadium 31CrV3 / 1.2208
- square drive according to DIN 3120, ISO 1174, with ball locking device resp. with ball retaining groove
- according to DIN 3123, ISO 3316



6,3

1/4"

Code	Number	l/mm	Pieces	Weight/g
1450000082000	1450-8	45	6	25

03

1450-../870-10

SOCKET CONVERTER 1/4"

- matt chrome-plated
- ELORA-Chrome-Vanadium 31CrV3 / 1.2208
- square drive according to DIN 3120, ISO 1174, with ball locking device resp. with ball retaining groove
- according to DIN 3123, ISO 3316

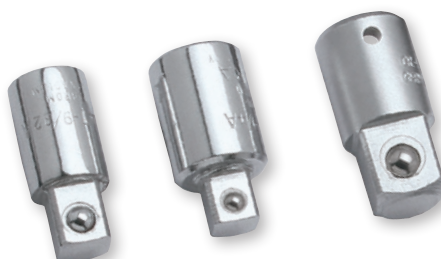

6,3

1/4"

Code	Number	□	○	l/mm	Pieces	Weight/g
1450000132000	1450-13	9/32"	1/4"	26	6	11
1450000142000	1450-14	1/4"	9/32"	26	6	15
1450000152000	1450-15	3/8"	1/4"	26	6	16
0870011002000	870-10	1/4"	3/8"	39	6	34

1450-16

SOCKET CONVERTER 1/4"

- matt chrome-plated
- ELORA-Chrome-Vanadium 31CrV3 / 1.2208
- female hexagon according to DIN 3126-D 6,3, with bit retaining spring
- female square according to DIN 3120-C 6,3, ISO 1174, with ball retaining groove



6,3

1/4"

Code	Number	l/mm	□	○	Pieces	Weight/g
1450000162000	1450-16	25	1/4"	1/4"	6	12

1430-... SOCKET SET 1/4"

- MU=16 pcs., AU=14 pcs.
- in black metal storage case with OMS-hard foam insert
- square drive according to DIN 3120, ISO 1174
- operation tools according to DIN 3122, ISO 3315

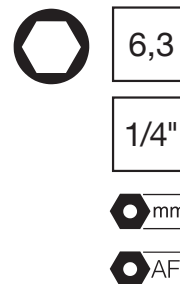

Code	Number	Ratchet	Sockets	Accessories	Pieces	Weight/g
1430504132000	1430-MU	Reversible Ratchet 1450-1D	Hexagon Sockets 1455-M 4, 4.5, 5, 5.5, 6, 7, 8, 9, 10, 11, 13 mm	Spinner Handle 1450-3 Sliding T-Bar 1450-4 Extension Bar 100 mm 1450-5 Universal Joint 1450-8	1	924
1430609232000	1430-AU	Reversible Ratchet 1450-1D	Hexagon Sockets 1455A-3/16, 7/32, 1/4, 9/32, 5/16, 11/32, 3/8, 7/16, 1/2 AF	Spinner Handle 1450-3 Sliding T-Bar 1450-4 Extension Bar 100 mm 1450-5 Universal Joint 1450-8	1	790

1430-TXU/TTXU SOCKET SET 1/4"

- 14 pcs.
- suitable for inside TORX® screws resp. inside TORX® safety screws
- in black metal storage case with plastic insert
- square drive according to DIN 3120, ISO 1174
- operation tools according to DIN 3122, ISO 3315
- TORX® = reg. trademark of Acument Intellectual Properties, LLC. USA



Code	Number	Ratchet	Sockets	Accessories	Pieces	Weight/g
1430505102000	1430-TXU	Reversible Ratchet 1450-1D	Screwdriver Sockets 3243-TX 8, 9, 10, 15, 20, 25, 27, 30, 40	Spinner Handle 1450-3 Sliding T-Bar 1450-4 Extension Bar 100 mm 1450-5 Universal Joint 1450-8	1	782
1430505202000	1430-TTXU	Reversible Ratchet 1450-1D	Screwdriver Sockets 3243-TTX 8, 9, 10, 15, 20, 25, 27, 30, 40	Spinner Handle 1450-3 Sliding T-Bar 1450-4 Extension Bar 100 mm 1450-5 Universal Joint 1450-8	1	775

1430-TXEU/TTXEU SOCKET SET 1/4"

- 21 pcs.
- suitable for inside- and outside TORX® screws resp. inside TORX® safety screws
- in black metal storage case with OMS-hard foam insert
- square drive according to DIN 3120, ISO 1174
- operation tools according to DIN 3122, ISO 3315
- TORX® = reg. trademark of Acument Intellectual Properties, LLC. USA

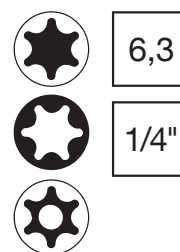

Code	Number	Ratchet	Sockets	Accessories	Pieces	Weight/g
1430505302000	1430-TXEU	Reversible Ratchet 1450-1D	Sockets 1455-TXE 4, 5, 6, 7, 8, 10, 11 Screwdriver Sockets 3243-TX 8, 9, 10, 15, 20, 25, 27, 30, 40	Spinner Handle 1450-3 Sliding T-Bar 1450-4 Extension Bar 100 mm 1450-5 Universal Joint 1450-8	1	780
1430505402000	1430-TTXEU	Reversible Ratchet 1450-1D	Sockets 1455-TXE 4, 5, 6, 7, 8, 10, 11 Screwdriver Sockets 3243-TTX 8, 9, 10, 15, 20, 25, 27, 30, 40	Spinner Handle 1450-3 Sliding T-Bar 1450-4 Extension Bar 100 mm 1450-5 Universal Joint 1450-8	1	843

1400-I... SOCKET SET 1/4"

- MU=21 pcs., AU=20 pcs.
- in black metal storage case with OMS-hard foam insert
- square drive according to DIN 3120, ISO 1174
- operation tools according to DIN 3122, ISO 3315

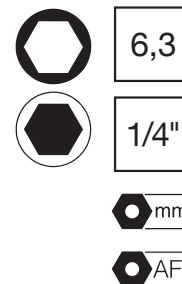

Code	Number	Ratchet	Sockets	Accessories	Pieces	Weight/g
1400514132000	1400-IMU	Reversible Ratchet 1450-1D	Sockets 1455-M 4, 4,5, 5, 5,5, 6,7, 8, 9, 10, 11, 13 mm Screwdriver Sockets 1455-IN 3, 4, 5, 6, 8 mm	Spinner Handle 1450-3 Sliding T-Bar 1450-4 Extension Bar 100 mm 1450-5 Universal Joint 1450-8	1	880
1400619232000	1400-IAU	Reversible Ratchet 1450-1D	Sockets 1455-A- 3/16, 7/32, 1/4, 9/32, 5/16, 11/32, 3/8, 7/16, 1/2 AF Screwdriver Sockets 1455-IN 1/8, 5/32, 3/16, 7/32, 1/4, 5/16 AF"	Spinner Handle 1450-3 Sliding T-Bar 1450-4 Extension Bar 100 mm 1450-5 Universal Joint 1450-8	1	872

714-6MU

SOCKET SET 1/4" AND 1/2"

- 25 pcs.
- in black metal storage case with plastic insert
- square drive according to DIN 3120, ISO 1174
- operation tools according to DIN 3122, ISO 3315

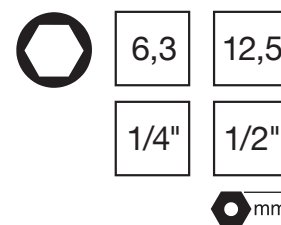

Code	Number	Ratchet	Sockets	Accessories	Pieces	Weight/g
0714562502000	714-6MU	1/4": Reversible Ratchet 1450-1D 1/2": Reversible Ratchet 770-L1D	Hexagon Sockets 1/4": 1455-M 5,5, 6, 7, 8, 9, 10, 11, 12, 13 mm 1/2": 771-LM 10, 13, 15, 17, 19, 22, 24, 27 mm	1/4": Spinner Handle 1450-3 Extension Bar 100 mm 1450-5 Universal Joint 1450-8 1/2": Extension Bar 125 mm 770-L5 Extension Bar 250 mm 770-L6 Universal Joint 770-L7"	1	3600

714-6MU OMS

SOCKET SET 1/4" AND 1/2", COMBINED

- 46 pcs.
- in black metal storage case with OMS-hard foam insert
- square drive according to DIN 3120, ISO 1174
- operation tools according to DIN 3122, ISO 3315

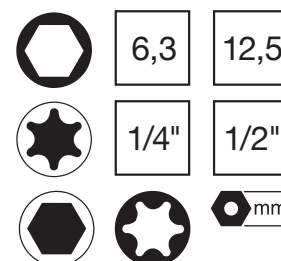

Code	Number	Ratchet	Sockets	Accessories	Pieces	Weight/g
0714562502046	714-6MU OMS	1/4": Reversible Ratchet 1450-1D 1/2": Reversible Ratchet 770-L1D	Sockets 1/4" 1455-M 5,5, 6, 7, 8, 9, 10, 11, 12, 13 mm 1455-TXE 4, 5, 6, 7, 8, 10, 11 Hexagon Sockets 1/2" 771-LM 10, 13, 15, 17, 19, 22, 24, 27 mm Screwdriver Sockets 1/4" 3243-TX 8, 9, 10, 15, 20, 25, 27, 30, 40 1455-IN 3, 4, 5, 6, 8 mm	1/4": Spinner Handle 1450-3 Extension Bar 100 mm 1450-5 Universal Joint 1450-8 1/2": Extension Bar 125 mm 770-L5 Extension Bar 250 mm 770-L6 Universal Joint 770-L7	1	3600

1440-...

SOCKET SET 1/4"

- MU=30 pcs., AU=31 pcs.
- in black metal storage case with OMS-hard foam insert
- square drive according to DIN 3120, ISO 1174
- operation tools according to DIN 3122, ISO 3315

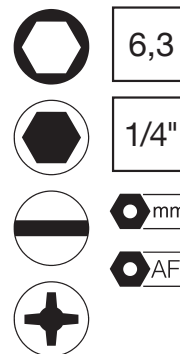

Code	Number	Ratchet	Sockets	Accessories	Pieces	Weight/g
1440504142000	1440-MU	Reversible Ratchet 1450-1D	Sockets 1455-M 4, 4,5, 5, 5,5, 6, 7, 8, 9, 10, 11, 12, 13, 14 mm Screwdriver Sockets 1455-IN 3, 4, 5, 6, 8 mm 1455-IS 4, 5,5, 6,5 mm 1455-PH 1, 2, 3	Spinner Handle 1450-3 Sliding T-Bar 1450-4 Extension Bar 50 mm 1450-11 Extension Bar 100 mm 1450-5 Extension Bar 150 mm 1450-12 Universal Joint 1450-8	1	1160
1440608242000	1440-AU	Reversible Ratchet 1450-1D	Sockets 1455A- 5/32, 3/16, 7/32, 1/4, 9/32, 5/16, 11/32, 3/8, 7/16, 1/2, 9/16 AF Screwdriver Sockets 1455-IN 1/8, 5/32, 3/16, 7/32, 1/4, 5/16 AF 1455-IS 4, 5,5, 6,5 mm 1455-PH 1, 2, 3	Spinner Handle 1450-3 Sliding T-Bar 1450-4 Extension Bar 50 mm 1450-11 Extension Bar 100 mm 1450-5 Extension Bar 150 mm 1450-12 Universal Joint 1450-8	1	1145

1400-TXE

SOCKET SET 1/4"

- 16-pcs.
- suitable for inside- and outside TORX® screws
- in black metal storage case with OMS-hard foam insert
- female square according to DIN 3120-C, 6,3, ISO 1174, with ball retaining groove
- TORX® = reg. trademark of Acument Intellectual Properties, LLC. USA



Code	Number	Contents	Pieces	Weight/g
1400510529000	1400-TXE	Sockets 1/4" for outside TORX® screws 1455-TXE 4, 5, 6, 7, 8, 10, 11 mm Screwdriver Sockets 1/4" for inside TORX® screws 3243-TTX 8, 9, 10, 15, 20, 25, 27, 30, 40 mm	1	1500

You will find combined socket sets 1/4" and 1/2" on page no. 135



870-1D

REVERSIBLE RATCHET 3/8", FINE TOOTH

- rugged ratchet with small, slim head
- forged gear wheel with safety locking and quick release button
- smallest possible swivel angle 5°
- nonslip QUATROLIT®-2C-handle
- with suspension hole
- matt chrome-plated
- ELORA-Chrome-Vanadium 31CrV3 / 1.2208
- male square according to DIN 3120-A 10, ISO 1174, with ball locking device
- according to DIN 3122, ISO 3315



10
3/8"

Code	Number	l/mm	Pieces	Weight/g
0870001012000	870-1D	200	1	240
0870010132000	870-E1D	Repair Kit	1	60

870-1UN

REVERSIBLE RATCHET 3/8", FINE TOOTH

- with small, round head
- forged, fine toothed wheel with grippy metal switching disk
- smallest possible swivel angle 5°
- nonslip QUATROLIT®-2C-handle
- with suspension hole
- matt chrome-plated
- ELORA-Chrome-Vanadium 31CrV3 / 1.2208
- male square according to DIN 3120-A 10, ISO 1174, with ball locking device
- according to DIN 3122, ISO 3315



10
3/8"

Code	Number	l/mm	Pieces	Weight/g
0870001012900	870-1UN	195	1	221
0870010182000	870-E1UN	Repair Kit	1	50

870-1ZI

PUSH THROUGH RATCHET 3/8"

- extremely rugged ratchet with round head
- forged gear wheel with push through square coupler
- smallest possible swivel angle 15°
- plastic handle
- matt chrome-plated
- ELORA-Chrome-Vanadium 31 CrV 3 / 1.2208
- square according to DIN 3120-A 10, ISO 1174, with ball locking device
- according to DIN 3122, ISO 3315

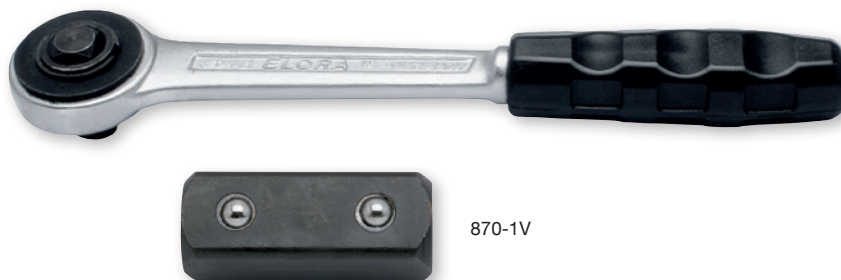

10
3/8"

Code	Number	l/mm	Pieces	Weight/g
0870010112000	870-1ZI	200	1	239
0870010122000	870-1V	25	12	35
0870010152000	870-E1ZI	Repair Kit	1	70

870-M..., 870-A..., 870-W...

SOCKET 3/8", BI-HEXAGON

- hot forged
- chrome-plated, polished
- knurled
- ELORA-Chrome-Vanadium 31CrV3 / 1.2208
- female square according to DIN 3120-C 10, ISO 1174, with ball retaining groove
- according to DIN 3124, ISO 2725-1



10

3/8"

mm

AF"

Code	Number	l/mm	Pieces	Weight/g
0870000062000	870-M 6	25	6	24
0870000072000	870-M 7	25	6	24
0870000082000	870-M 8	25	6	24
0870000092000	870-M 9	25	6	26
0870000102000	870-M 10	25	6	26
0870000112000	870-M 11	25	6	26
0870000122000	870-M 12	25	6	26
0870000132000	870-M 13	25	6	28
0870000142000	870-M 14	25	6	28
0870000152000	870-M 15	25	6	30
0870000162000	870-M 16	25	6	30
0870000172000	870-M 17	26	6	38
0870000182000	870-M 18	27	6	38
0870000192000	870-M 19	28	6	38
0870000202000	870-M 20	28	6	46
0870000212000	870-M 21	28,5	6	52
0870000222000	870-M 22	28,5	6	60
0870000242000	870-M 24	28,5	6	68

Code	Number	l/mm	Pieces	Weight/g
0870100192000	870-A 3/8	25	6	26
0870100212000	870-A 7/16	25	6	26
0870100232000	870-A 1/2	25	6	26
0870100242000	870-A 9/16	25	6	26
0870100252000	870-A 19/32	25	6	30
0870100262000	870-A 5/8	25	6	32
0870100272000	870-A 11/16	26	6	40
0870100282000	870-A 3/4	28	6	46
0870100292000	870-A 25/32	28	6	46
0870100302000	870-A 13/16	29	6	48
0870100312000	870-A 7/8	29	6	52

WW

Code	Number	l/mm	Pieces	Weight/g
0870200092000	870-W 3/16	25	6	26
0870200132000	870-W 1/4	25	6	26
0870200172000	870-W 5/16	25	6	30
0870200192000	870-W 3/8	27	6	34
0870200232000	870-W 1/2	28,5	6	60

871-M..., 871-A..., 871-W..., 871-BA...

SOCKET 3/8", HEXAGON

- hot forged
- chrome-plated, polished
- knurled
- ELORA-Chrome-Vanadium 31CrV3 / 1.2208
- female square according to DIN 3120-C 10, ISO 1174, with ball retaining groove
- according to DIN 3124, ISO 2725-1



10

3/8"

mm

AF"

Code	Number	l/mm	Pieces	Weight/g
0871000062000	871-M 6	25	6	24
0871000072000	871-M 7	25	6	24
0871000082000	871-M 8	25	6	24
0871000092000	871-M 9	25	6	26
0871000102000	871-M 10	25	6	26
0871000112000	871-M 11	25	6	26
0871000122000	871-M 12	25	6	26
0871000132000	871-M 13	25	6	28
0871000142000	871-M 14	25	6	28
0871000152000	871-M 15	25	6	30
0871000162000	871-M 16	25	6	30
0871000172000	871-M 17	26	6	38
0871000182000	871-M 18	27	6	38
0871000192000	871-M 19	28	6	38
0871000202000	871-M 20	28	6	46
0871000212000	871-M 21	28,5	6	52
0871000222000	871-M 22	28,5	6	60
0871000242000	871-M 24	28,5	6	68

Code	Number	l/mm	Pieces	Weight/g
0871100132000	871-A1/4	25	6	24
0871100172000	871-A5/16	25	6	24

870-T...

SOCKET 3/8", EXTRA DEEP, BI-HEXAGON

- especially suitable for deep-set female screws on long threaded bolts
- hot forged
- chrome-plated, polished
- knurled
- ELORA-Chrome-Vanadium 31CrV3 / 1.2208
- female square according to DIN 3120-C 10, ISO 1174, with ball retaining groove
- according to DIN 3124, ISO 2725-1



10

3/8"



870-TXE...

SOCKET 3/8"

- for outside TORX® screws
- chrome-plated, polished
- knurled
- ELORA-Chrome-Vanadium 31CrV3 / 1.2208
- female square according to DIN 3120-C 10, ISO 1174, ball retaining groove
- TORX® = reg. trademark of Acument Intellectual Properties, LLC. USA



10

3/8"



Code	Number	l/mm ┆	Pieces ☞	Weight/g ⚖
0870003102000	870-T 10	65	6	45
0870003112000	870-T 11	65	6	50
0870003122000	870-T 12	65	6	55
0870003132000	870-T 13	65	6	60
0870003142000	870-T 14	65	6	65
0870003152000	870-T 15	65	6	70
0870003162000	870-T 16	70	6	80
0870003172000	870-T 17	70	6	95
0870003182000	870-T 18	70	6	105
0870003192000	870-T 19	70	6	108
0870003202000	870-T 20	70	6	120
0870003212000	870-T 21	70	6	125
0870003222000	870-T 22	70	6	128

Code	Number	mm ★	l/mm ┆	Pieces ☞	Weight/g ⚖
0870020052000	870-TXE 5	4,75	31	6	36
0870020062000	870-TXE 6	5,74	31	6	37
0870020072000	870-TXE 7	6,22	31	6	37
0870020082000	870-TXE 8	7,52	31	6	37
0870020102000	870-TXE 10	9,42	31	6	40
0870020112000	870-TXE 11	9,98	31	6	40
0870020122000	870-TXE 12	11,17	31	6	40
0870020142100	870-TXE 14	12,85	31	6	44

You will find the matching spark plug sockets on page no. 439, 440



870-11

SCREWDRIVER SOCKET 3/8"

- for plain slotted screws
- chrome-plated, polished
- ELORA-Chrome-Vanadium 31CrV3 / 1.2208
- female square according to DIN 3120-C 10, ISO 1174, with ball retaining groove

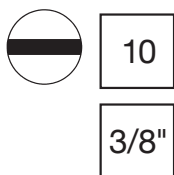

Code	Number	Blade Size mm	l/mm	Pieces	Weight/g
0870011102000	870-11	16x3,0	39	6	52

3500-IS...

SCREWDRIVER SOCKET 3/8"

- for plain slotted screws
- chrome-plated, polished
- knurled
- holder made of ELORA-Chrome-Vanadium 31CrV3 / 1.2208
- Female square according to DIN 3120-C 10, ISO 1174, with ball retaining groove
- blade made of ELORA-Vanadium special steel, gunmetal finished
- blade according to DIN ISO 2380-1 Form B

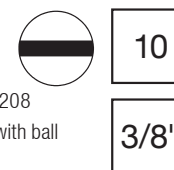

Code	Number	Blade Size mm	l/mm	Pieces	Weight/g
3500000082000	3500-IS 0,8	0,8x4,0	52	6	50
3500000102000	3500-IS 1,0	1,0x5,5	52	6	50
3500000122000	3500-IS 1,2	1,2x8,0	52	6	52

3520-PH...

SCREWDRIVER SOCKET 3/8"

- for cross slotted screws
- chrome-plated, polished
- knurled
- holder made of ELORA-Chrome-Vanadium 31CrV3 / 1.2208
- female square according to DIN 3120-C 10, ISO 1174, with ball retaining groove
- blade made of ELORA-Vanadium special steel, gunmetal finished
- blade according to DIN ISO 8764-1 PH

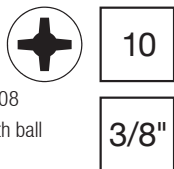

Code	Number	l/mm	Pieces	Weight/g
3520000032000	3520-PH 3	48	6	52
3520000042000	3520-PH 4	48	6	52

3510-IN...

SCREWDRIVER SOCKET 3/8"

- for inside hexagon screws
- chrome-plated, polished
- knurled
- holder made of ELORA-Chrome-Vanadium 31CrV3 / 1.2208
- female square according to DIN 3120-C 10, ISO 1174, with ball retaining groove
- blade made of ELORA-Vanadium special steel, gunmetal finished
- according to DIN 7422



Code	Number	mm	l/mm	Pieces	Weight/g
3510000032000	3510-IN 3	M4	44	6	50
3510000042000	3510-IN 4	M5	44	6	50
3510000052000	3510-IN 5	M6	44	6	52
3510000062000	3510-IN 6	M8	44	6	52
3510000072000	3510-IN 7		44	6	54
3510000082000	3510-IN 8	M10	44	6	54
3510000092000	3510-IN 9		44	6	58
3510000102000	3510-IN 10	M12	44	6	58
3510000122000	3510-IN 12	M14	44	6	58

Code	Number	l/mm	Pieces	Weight/g
3510100062000	3510-IN 1/8	44	6	48
3510100082000	3510-IN 5/32	44	6	48
3510100092000	3510-IN 3/16	44	6	48
3510100112000	3510-IN 7/32	44	6	48
3510100132000	3510-IN 1/4	44	6	52
3510100172000	3510-IN 5/16	44	6	52
3510100192000	3510-IN 3/8	44	6	58

3510-INL...

SCREWDRIVER SOCKET 3/8", LONG

- for inside hexagon screws
- chrome-plated, polished
- knurled
- holder made of ELORA-Chrome-Vanadium 31CrV3 / 1.2208
- female square according to DIN 3120-C 10, ISO 1174, with ball retaining groove
- blade made of ELORA-Vanadium special steel, gunmetal finished
- according to DIN 7422

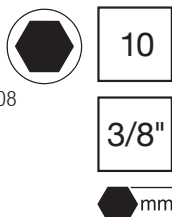

Code	Number	mm	l/mm	Pieces	Weight/g
3510010042100	3510-INL 4x100	M5	100	6	70
3510010052100	3510-INL 5x100	M6	100	6	72
3510010052180	3510-INL 5x180	M6	180	6	108
3510010062100	3510-INL 6x100	M6	100	6	77
3510010062220	3510-INL 6x220	M6	220	6	122
3510010082100	3510-INL 8x100	M10	100	6	74
3510010102130	3510-INL 10x130	M12	130	6	116

3244-TXL-45

SCREWDRIVER SOCKET 3/8", LONG

- for inside TORX® screws
- chrome-plated, polished
- knurled
- holder made of ELORA-Chrome-Vanadium 31CrV3 / 1.2208
- female square according to DIN 3120-C 10, ISO 1174, with ball retaining groove
- blade made of ELORA-Vanadium special steel, gunmetal finished
- TORX® = reg. trademark of Acument Intellectual Properties, LLC. USA

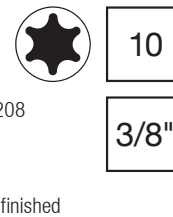

Code	Number	mm	l/mm	Pieces	Weight/g
3244020451100	3244-TXL 45	7,82	100	6	87

3244-TX...

SCREWDRIVER SOCKET 3/8"

- for inside TORX® screws
- chrome-plated, polished
- knurled
- holder made of ELORA-Chrome-Vanadium 31CrV3 / 1.2208
- female square according to DIN 3120-C 10, ISO 1174, with ball retaining groove
- blade made of ELORA-Vanadium special steel, gunmetal finished
- TORX® = reg. trademark of Acument Intellectual Properties, LLC. USA

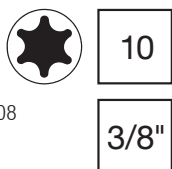

Code	Number	mm	l/mm	Pieces	Weight/g
3244000092000	3244-TX 9	2,50	46	6	50
3244000102000	3244-TX 10	2,74	46	6	50
3244000152000	3244-TX 15	3,27	46	6	52
3244000202000	3244-TX 20	3,86	46	6	54
3244000252000	3244-TX 25	4,43	46	6	54
3244000272000	3244-TX 27	4,99	46	6	54
3244000302000	3244-TX 30	5,52	46	6	60
3244000402000	3244-TX 40	6,65	46	6	62
3244000452000	3244-TX 45	7,82	46	6	65
3244000502000	3244-TX 50	8,83	46	6	70

3244-TTX...

SCREWDRIVER SOCKET 3/8"

- for Inside-TORX® safety screws
- with bore hole in tip
- chrome-plated, polished
- knurled
- holder made of ELORA-Chrome-Vanadium 31CrV3 / 1.2208
- female square according to DIN 3120-C 10, ISO 1174, with ball retaining groove
- blade made of ELORA-Vanadium special steel, gunmetal finished
- TORX® = reg. trademark of Acument Intellectual Properties, LLC. USA

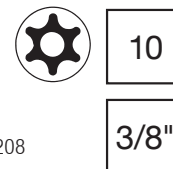

Code	Number	mm	l/mm	Pieces	Weight/g
3244010092000	3244-TTX 9	2,50	46	6	50
3244010102000	3244-TTX 10	2,74	46	6	50
3244010152000	3244-TTX 15	3,27	46	6	52
3244010202000	3244-TTX 20	3,86	46	6	54
3244010252000	3244-TTX 25	4,43	46	6	54
3244010272000	3244-TTX 27	4,99	46	6	54
3244010302000	3244-TTX 30	5,52	46	6	60
3244010402000	3244-TTX 40	6,65	46	6	62
3244010452000	3244-TTX 45	7,82	46	6	65
3244010502000	3244-TTX 50	8,83	46	6	70

3530-XZN...

SCREWDRIVER SOCKET 3/8"

- ▶ for inside multi-point B & S and XZN screws
- ▶ chrome-plated, polished
- ▶ knurled
- ▶ holder made of ELORA-Chrome-Vanadium 31CrV3 / 1.2208
- ▶ female square according to DIN 3120-C 10, ISO 1174, with ball retaining groove
- ▶ blade made of ELORA-Vanadium special steel, gunmetal finished
- ▶ Blade according to DIN 2325



10

3/8"



Code	Number	mm	l/mm	Pieces	Weight/g
3530000052000	3530-XZN 5	M5	44	6	48
3530000062000	3530-XZN 6	M6	44	6	50
3530000082000	3530-XZN 8	M8	45	6	50
3530000102000	3530-XZN 10	M10	45	6	58

3530-XZNL...

SCREWDRIVER SOCKET 3/8", EXTRA LONG

- ▶ for inside multi-point screws
- ▶ suitable for inside B & S and XZN screws
- ▶ chrome-plated, polished
- ▶ knurled
- ▶ holder made of ELORA-Chrome-Vanadium 31CrV3 / 1.2208
- ▶ female square according to DIN 3120-C 10, ISO 1174, with ball retaining groove
- ▶ blade made of ELORA-Vanadium special steel, gunmetal finished
- ▶ blade according to DIN 2325



10

3/8"



Code	Number	mm	l/mm	Pieces	Weight/g
3530010102093	3530-XZNL 10x93	M10	93	6	92

779-...

CROW FOOT SPANNER 3/8"

- ▶ for cap nuts and pipe fittings
- ▶ chrome-plated
- ▶ Chrome-Vanadium 31CrV3 / 1.2208
- ▶ female square according to DIN 3120-C 10 ISO 1174



10

3/8"

Code	Number	l/mm	Pieces	Weight/g
0779000105100	779-10	39,0	6	35
0779000115100	779-11	40,0	6	35
0779000125100	779-12	41,0	6	35
0779000135100	779-13	41,0	6	35
0779000145100	779-14	42,0	6	45
0779000155100	779-15	43,0	6	45
0779000165100	779-16	46,0	6	45
0779000175100	779-17	46,0	6	60
0779000185100	779-18	48,0	6	60

870-M SB

PLASTIC HOLDER 3/8"

- ▶ appropriate for sockets nominal size 10 (3/8") and operation tools with female square



10

3/8"

Code	Number	Pieces	Weight/g
0000700387000	870-M SB	1	10

870-KL, 870-MKL

SOCKET RAIL 3/8"

- **870-KL:**
- 15 shiftable socket clips
- two holes allow permanent mounting
- chrome-plated, polished

10

3/8"

- **870-MKL:**
- 11 shiftable socket clips
- strong magnet enables firm mounting
- black coated



Code	Number	l/mm	Pieces	Weight/g
0000938146000	870-KL	414	1	72
0000938146001	870-MKL	300	1	172

03



You will find the matching BIG SPENDER on page no. 163, 164



870-7

FLEXIBLE HANDLE 3/8"

- matt chrome-plated
- plastic handle
- ELORA-Chrome-Vanadium 31CrV3 / 1.2208
- male square according to DIN 3120-A 10, ISO 1174, with ball locking device
- according to DIN 3122, ISO 3315

10

3/8"



Code	Number	l/mm	Pieces	Weight/g
0870010702000	870-7	250	6	240

870-12

SPINNER-HANDLE 3/8"

- nonslip QUATROLIT®-2C-handle
- with suspension hole
- matt chrome-plated
- ELORA-Chrome-Vanadium 31CrV3 / 1.2208
- male square according to DIN 3120-A 10, ISO 1174, with ball locking device
- according to DIN 3122, ISO 3315

10

3/8"



Code	Number	l/mm	Pieces	Weight/g
0870011202000	870-12	180	6	170

870-8

SLIDING T-BAR 3/8"

- matt chrome-plated
- ELORA-Chrome-Vanadium 31CrV3 / 1.2208
- male square according to DIN 3120-A 10, ISO 1174, with ball locking device
- according to DIN 3122, ISO 3315

10

3/8"



Code	Number	l/mm	Pieces	Weight/g
0870010802000	870-8	200	6	155

870-2

SPEED BRACE 3/8"

- matt chrome-plated
- plastic handle
- ELORA-Chrome-Vanadium 31CrV3 / 1.2208
- male square according to DIN 3120-A 10, ISO 1174, with ball locking device
- according to DIN 3122, ISO 3315

10

3/8"



Code	Number	l/mm	Pieces	Weight/g
0870010202000	870-2	345	6	345

870-...

EXTENSION BAR 3/8"

- matt chrome-plated, head polished
- ELORA-Chrome-Vanadium 31CrV3 / 1.2208
- square drive according to DIN 3120, ISO 1174, with ball retaining groove resp. with ball locking device
- according to DIN 3123, ISO 3316

10

3/8"

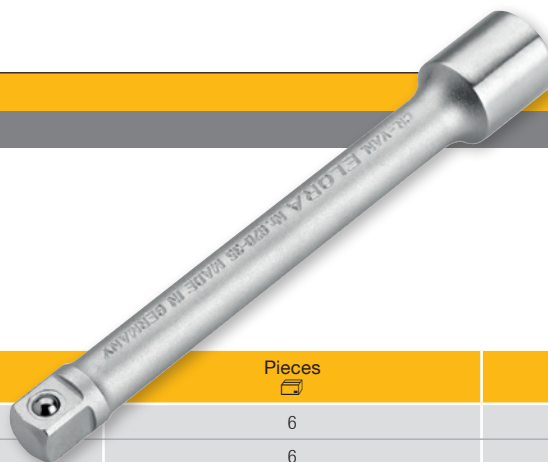

Code	Number	l/mm	Pieces	Weight/g
0870010252000	870-25	35	6	42
0870010302000	870-3	75	6	68
0870010352000	870-35	125	6	104
0870010402000	870-4	150	6	124
0870010502000	870-5	200	6	170
0870010552000	870-55	250	6	200
0870010602000	870-6	300	6	240
0870010662000	870-66	500	6	390

870-V...

EXTENSION BAR 3/8", SWIVELLING

- matt chrome-plated, head polished
- with special square for a swivel angle of 8° to each side
- especially suitable for screw connections within confined spaces
- ELORA-Chrome-Vanadium 31CrV3 / 1.2208
- square drive according to DIN 3120, ISO 1174, with ball retaining groove resp. with ball locking device
- according to DIN 3123, ISO 3316

10

3/8"



Code	Number	l/mm	Pieces	Weight/g
0870010302100	870-3V	75	6	68
0870010352100	870-35V	125	6	104
0870010402500	870-4V	150	6	124
0870010552500	870-55V	250	6	200

870-9

UNIVERSAL JOINT 3/8"

- chrome-plated, polished
- ELORA-Chrome-Vanadium 31CrV3 / 1.2208
- square drive according to DIN 3120, ISO 1174, with ball retaining groove resp. with ball locking device
- according to DIN 3123, ISO 3316

10

3/8"



Code	Number	l/mm	Pieces	Weight/g
0870010902000	870-9	55	6	68

870-10/770-L.../1450-15

SOCKET CONVERTER

- matt chrome-plated
- ELORA-Chrome-Vanadium 31CrV3 / 1.2208
- square drive according to DIN 3120, ISO 1174, with ball locking device resp. with ball retaining groove
- according to DIN 3123, ISO 3316

10

3/8"



Code	Number	□	○	l/mm	Pieces	Weight/g
0870011002000	870-10	1/4"	3/8"	32	6	34
0770013002000	770-L13	3/8"	1/2"	40	6	65
0770014002000	770-L14	1/2"	3/8"	36	6	60
1450000152000	1450-15	3/8"	1/4"	26	6	16

870-J.../871-J...

SOCKET SET 3/8"

- JMU=18 pcs., JAU=15 pcs.
- in black metal storage case with plastic insert
- square drive according to DIN 3120, ISO 1174, with ball retaining groove
- operation tools according to DIN 3122, ISO 3315



Code	Number	Ratchet	Sockets	Accessories	Pieces	Weight/g
0870500502000	870-JMU	Reversible Ratchet 870-1D	Bi-Hexagon Sockets 870-M 6, 7, 8, 9, 10, 11, 13, 14, 15, 16, 17, 18, 19, 21, 22 mm	Extension Bar 150 mm 870-4 Sliding T-Bar 870-8	1	1532
0871501802000	871-JMU	Reversible Ratchet 870-1D	Hexagon Sockets 871-M 6, 7, 8, 9, 10, 11, 13, 14, 15, 16, 17, 18, 19, 21, 22 mm	Extension Bar 150 mm 870-4 Sliding T-Bar 870-8	1	1500
0870500602000	870-JAU	Reversible Ratchet 870-1D	Hexagon Sockets 871-A 1/4, 5/16 AF Bi-Hexagon Sockets 870-A 3/8, 7/16, 1/2, 9/16, 19/32, 5/8, 11/16, 3/4, 13/16, 7/8 AF	Extension Bar 150 mm 870-4 Sliding T-Bar 870-8	1	1450

870-JSU/871-JSU

SOCKET SET 3/8"

- 20 pcs.
- in black metal storage case with plastic insert
- square drive according to DIN 3120, ISO 1174, with ball retaining groove
- operation tools according to DIN 3122, ISO 3315

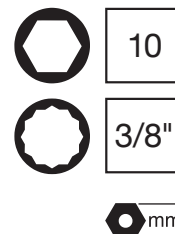

Code	Number	Ratchet	Sockets	Accessories	Pieces	Weight/g
0870500702000	870-JSU	Reversible Ratchet 870-1D	Bi-Hexagon Sockets 870-M 6, 7, 8, 9, 10, 11, 13, 14, 15, 16, 17, 18, 19, 21, 22 mm	Extension Bar 75 mm 870-3 Extension Bar 150 mm 870-4 Sliding T-Bar 870-8 Universal Joint 870-9	1	1993
0871502002000	871-JSU	Reversible Ratchet 870-1D	Hexagon Sockets 871-M 6, 7, 8, 9, 10, 11, 13, 14, 15, 16, 17, 18, 19, 21, 22 mm	Extension Bar 75 mm 870-3 Extension Bar 150 mm 870-4 Sliding T-Bar 870-8 Universal Joint 870-9	1	1900

You will find the matching OMS-34/21 module on page no.32



870-.../871-MU

SOCKET SET 3/8"

- MU=27 pcs., AU=22 pcs.
- in black metal storage case with plastic insert
- square drive according to DIN 3120, ISO 1174, with ball retaining groove
- operation tools according to DIN 3122, ISO 3315

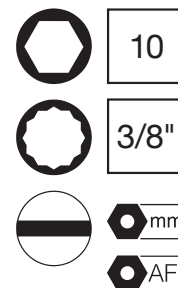
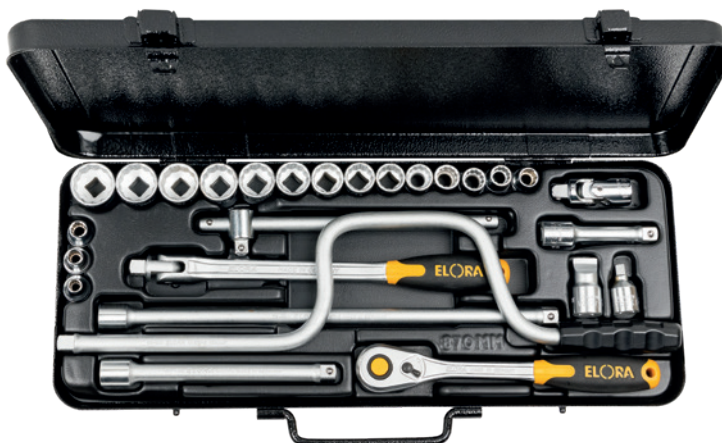

03

Code	Number	Ratchet	Sockets	Accessories	Pieces	Weight/g
0870500102000	870-MU	Reversible Ratchet 870-1D	Bi-Hexagon Sockets 870-M 6, 7, 8, 9, 10, 11, 12, 13, 14, 15, 16, 17, 18, 19, 20, 21, 22 mm Screwdriver Socket 870-11, IS 16x3,0 mm	Speed Brace 870-2 Extension Bar 75 mm 870-3 Extension Bar 150 mm 870-4 Extension Bar 300 mm 870-6 Flexible Handle 870-7 Sliding T-Bar 870-8 Universal Joint 870-9 Socket Converter 870-10, Male 1/4, Female 3/8	1	3520
0871502202000	871-MU	Reversible Ratchet 870-1D	Hexagon Sockets 871-M 6, 7, 8, 9, 10, 11, 12, 13, 14, 15, 16, 17, 18, 19, 20, 21, 22 mm Screwdriver Socket 870-11, IS 16x3,0 mm	Speed Brace 870-2 Extension Bar 75 mm 870-3 Extension Bar 150 mm 870-4 Extension Bar 300 mm 870-6 Flexible Handle 870-7 Sliding T-Bar 870-8 Universal Joint 870-9 Socket Converter 870-10, Male 1/4, Female 3/8	1	3900
0870500202000	870-AU	Reversible Ratchet 870-1D	Hexagon Sockets 871-A 1/4, 5/16 AF Bi-Hexagon Sockets 870-A 3/8, 7/16, 1/2, 9/16, 19/32, 5/8, 11/16, 3/4, 13/16, 7/8 AF Screwdriver Socket 870-11, IS 16x3,0 mm	Speed Brace 870-2 Extension Bar 75 mm 870-3 Extension Bar 150 mm 870-4 Extension Bar 300 mm 870-6 Flexible Handle 870-7 Sliding T-Bar 870-8 Universal Joint 870-9 Socket Converter 870-10, Male 1/4, Female 3/8	1	3380

870-IN...

SOCKET SET 3/8"

- 8 pcs.
- in black metal storage case with plastic insert
- square drive according to DIN 3120, ISO 1174, with ball retaining groove
- operation tools according to DIN 3122, ISO 3315



10

3/8"

mm

AF"

Code	Number	Ratchet	Sockets	Accessories	Pieces	Weight/g
0870510002000	870-INMU	Reversible Ratchet 870-1D	Screwdriver Sockets for inside Hexagon screws 3510-IN 3, 4, 5, 6, 8, 10 mm	Extension Bar 125 mm 870-35	1	1181
0870610002000	870-INAU	Reversible Ratchet 870-1D	Screwdriver Sockets for inside Hexagon screws 3510-IN 1/8, 5/32, 3/16, 7/32, 1/4, 5/16 AF	Extension Bar 125 mm 870-35	1	1168

870-TXU/TTXU

SOCKET SET 3/8"

- 12 pcs.
- suitable for inside TORX® screws resp. inside TORX® safety screws
- in black metal storage case with plastic insert
- square drive according to DIN 3120, ISO 1174, with ball retaining groove
- operation tools according to DIN 3122, ISO 3315
- TORX® = reg. trademark of Acument Intellectual Properties, LLC. USA



10



3/8"

Code	Number	Ratchet	Sockets	Accessories	Pieces	Weight/g
0870520102100	870-TXU	Reversible Ratchet 870-1D	Screwdriver Sockets for TORX®-screws 3244-TX 9, 10, 15, 20, 25, 27, 30, 40, 45, 50 mm	Extension Bar 125 mm 870-35	1	1378
0870521102000	870-TTXU	Reversible Ratchet 870-1D	Screwdriver Sockets for TORX®-screws 3244-TTX 9, 10, 15, 20, 25, 27, 30, 40, 45, 50 mm	Extension Bar 125 mm 870-35	1	1354

877-TXE

SOCKET SET 3/8"

- 13 pcs.
- suitable for outside TORX® screws
- in black metal storage case with plastic insert
- square drive according to DIN 3120, ISO 1174, with ball retaining groove
- TORX® = reg. trademark of Acument Intellectual Properties, LLC. USA



10

3/8"

12,5

1/2"

Code	Number	Sockets	Accessories	Pieces	Weight/g
0877500102000	877-TXE	Sockets 3/8" for outside TORX®-screws 870-TXE 5, 6, 7, 8, 10, 11, 12, 14 mm Sockets 1/2" for outside TORX®-screws 770-LTXE 16, 18, 20, 24 mm	Socket Converter 770-L13, Male 3/8, Female 1/2	1	1245

770-L1D

REVERSIBLE RATCHET 1/2"

- rugged ratchet with small, slim head
- forged gear wheel with male and female square
- smallest possible swivel angle 11,25°
- nonslip QUATROLIT®-2C-handle
- with suspension hole
- matt chrome-plated
- ELORA-Chrome-Vanadium 31CrV3 / 1.2208
- male square according to DIN 3120-A 12,5, ISO 1174, with ball locking device
- according to DIN 3122, ISO 3315



12,5

1/2"

Code	Number	l/mm	Pieces	Weight/g
0770000902000	770-L1D	270	1	530
0770000912001	770-LE1D	Repair Kit	1	120

770-L1F

REVERSIBLE RATCHET 1/2"

- rugged ratchet with small, slim head
- forged gear wheel with safety locking and quick release button
- smallest possible swivel angle 11,25°
- nonslip QUATROLIT®-2C-handle
- with suspension hole
- matt chrome-plated
- ELORA-Chrome-Vanadium 31CrV3 / 1.2208
- male square according to DIN 3120-A 12,5, ISO 1174, with ball locking device
- according to DIN 3122, ISO 3315



12,5

1/2"

Code	Number	l/mm	Pieces	Weight/g
0770000922000	770-L1F	270	1	525
0770000922003	770-LE1F	Repair Kit	1	120

770-L1K

REVERSIBLE RATCHET 1/2", FINE TOOTH

- with small, slim head
- forged gear wheel with safety locking and quick release button
- smallest possible swivel angle 5°
- nonslip QUATROLIT®-2C-handle
- with suspension hole
- matt chrome-plated
- ELORA-Chrome-Vanadium 31CrV3 / 1.2208
- male square according to DIN 3120-A 12,5, ISO 1174, with ball locking device
- according to DIN 3122, ISO 3315



12,5

1/2"

Code	Number	l/mm	Pieces	Weight/g
0770000802000	770-L1K	270	1	532
0770000852000	770-LE1K	Repair Kit	1	120

770-L1UN

REVERSIBLE RATCHET 1/2", FINE TOOTH

- with small, slim head
- forged, fine toothed wheel with grippy metal switching disk
- smallest possible swivel angle 5°
- nonslip QUATROLIT®-2C-handle
- with suspension hole
- matt chrome-plated
- ELORA-Chrome-Vanadium 31CrV3 / 1.2208
- male square according to DIN 3120-A 12,5, ISO 1174, with ball locking device
- according to DIN 3122, ISO 3315



12,5

1/2"

Code	Number	l/mm	Pieces	Weight/g
0770001012900	770-L1UN	260	1	508
0770001132000	770-LE1UN	Repair Kit	1	115

770-L115U

REVERSIBLE RATCHET 1/2"

- extra long design with slim head
- forged gear wheel with male and female square
- smallest possible swivel angle 11,25°
- nonslip QUATROLIT®-2C-handle
- with suspension hole
- matt chrome-plated
- ELORA-Chrome-Vanadium 31 CrV 3 / 1.2208
- male square according to DIN 3120-A 12,5, ISO 1174, with ball locking device



12,5

1/2"

Code	Number	l/mm	Pieces	Weight/g
0770001022000	770-L115U	375	1	656
0770000912001	770-LE1D	Repair Kit	1	120

770-L115F

REVERSIBLE RATCHET 1/2"

- extra long design with slim head
- forged gear wheel with safety locking and quick release button
- smallest possible swivel angle 11,25°
- nonslip QUATROLIT®-2C-handle
- with suspension hole
- matt chrome-plated
- ELORA-Chrome-Vanadium 31 CrV 3 / 1.2208
- male square according to DIN 3120-A 12,5, ISO 1174, with ball locking device



12,5

1/2"

Code	Number	l/mm	Pieces	Weight/g
0770001022100	770-L115F	375	1	662
0770000922003	770-LE1F	Repair Kit	1	120

770-L1G

REVERSIBLE RATCHET WITH HINGE 1/2"

- 180° swivelling
- forged gear wheel with male and female square
- smallest possible swivel angle 11,25°
- nonslip QUATROLIT®-2C-handle
- matt chrome-plated
- ELORA-Chrome-Vanadium 31CrV3 / 1.2208
- male square according to DIN 3120-A 12,5, ISO 1174, with ball locking device

12,5

1/2"



Code	Number	l/mm	Pieces	Weight/g
0770001032000	770-L1G	305	1	709
0770000912001	770-LE1D	Repair Kit	1	120

770-L1GF

REVERSIBLE RATCHET WITH HINGE 1/2"

- 180° swivelling
- forged gear wheel with safety locking and quick release button
- smallest possible swivel angle 11,25°
- nonslip QUATROLIT®-2C-handle
- matt chrome-plated
- ELORA-Chrome-Vanadium 31CrV3 / 1.2208
- male square according to DIN 3120-A 12,5, ISO 1174, with ball locking device

12,5

1/2"



Code	Number	l/mm	Pieces	Weight/g
0770001032100	770-L1GF	305	1	708
0770000922003	770-LE1F	Repair Kit	1	120

770-L115G

REVERSIBLE RATCHET WITH HINGE 1/2"

- extra long version
- 180° swivelling
- forged gear wheel with male and female square
- smallest possible swivel angle 11,25°
- nonslip QUATROLIT®-2C-handle
- with suspension hole
- matt chrome-plated
- ELORA-Chrome-Vanadium 31CrV3 / 1.2208
- male square according to DIN 3120-A 12,5, ISO 1174, with ball locking device

12,5

1/2"



Code	Number	l/mm	Pieces	Weight/g
0770001042000	770-L115G	430	1	879
0770000912001	770-LE1D	Repair Kit	1	135

770-L115GF

REVERSIBLE RATCHET WITH HINGE 1/2"

- extra long version
- 180° swivelling
- forged gear wheel with safety locking and quick release button
- smallest possible swivel angle 11,25°
- nonslip QUATROLIT®-2C-handle
- with suspension hole
- matt chrome-plated
- ELORA-Chrome-Vanadium 31CrV3 / 1.2208
- male square according to DIN 3120-A 12,5, ISO 1174, with ball locking device



12,5

1/2"

Code	Number	l/mm	Pieces	Weight/g
0770001042100	770-L115GF	430	1	879
0770000922003	770-LE1F	Repair Kit	1	120

770-L1ZI

PUSH THROUGH RATCHET 1/2"

- extremely rugged ratchet with round head
- forged gear wheel with push through square coupler
- smallest possible swivel angle 11,25°
- nonslip QUATROLIT®-2C-handle
- with suspension hole
- matt chrome-plated
- ELORA-Chrome-Vanadium 31CrV3 / 1.2208
- male square according to DIN 3120-A 12,5, ISO 1174, with ball locking device



770-L1V

12,5

1/2"

Code	Number	l/mm	Pieces	Weight/g
0770001062000	770-L1ZI	250	1	525
0770001072000	770-L1V	35	12	44
0770001092001	770-LE1ZI	Repair Kit	1	125

770-LM..., 770-LA..., 770-LW...

SOCKET 1/2", BI-HEXAGON

- hot forged
- chrome-plated, polished
- knurled
- ELORA-Chrome-Vanadium 31CrV3 / 1.2208
- female square according to DIN 3120-C 12,5, ISO 1174, with ball retaining groove
- according to DIN 3124, ISO 2725-1



12,5

1/2"

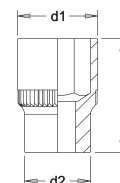

Code	Number	l/mm	d1 mm	d2 mm	Pieces	Weight/g
077000082000	770-LM 8	40	12,0	23,0	6	56
077000092000	770-LM 9	40	13,4	23,0	6	56
077000102000	770-LM 10	40	15,1	23,0	6	56
077000112000	770-LM 11	40	16,3	23,0	6	58
077000122000	770-LM 12	40	17,7	23,0	6	58
077000132000	770-LM 13	40	18,7	23,0	6	58
077000142000	770-LM 14	40	20,2	23,0	6	60
077000152000	770-LM 15	40	21,5	23,0	6	62
077000162000	770-LM 16	40	22,7	23,0	6	66
077000172000	770-LM 17	40	24,1	23,0	6	66
077000182000	770-LM 18	40	25,3	23,0	6	66
077000192000	770-LM 19	40	26,5	23,0	6	66
077000202000	770-LM 20	40	27,8	23,0	6	72
077000212000	770-LM 21	40	28,8	24,0	6	74
077000222000	770-LM 22	40	30,2	23,7	6	86
077000232000	770-LM 23	40	31,2	24,7	6	88
077000242000	770-LM 24	40	32,6	24,4	6	96
077000252000	770-LM 25	42	33,8	25,7	6	106
077000262000	770-LM 26	42	35,2	24,9	6	108
077000272000	770-LM 27	44	36,5	26,2	6	126
077000282000	770-LM 28	44	37,5	27,2	6	140
077000292000	770-LM 29	44	38,9	27,7	6	145
077000302000	770-LM 30	44	40,1	28,0	6	150
077000322000	770-LM 32	46	42,6	28,0	6	180
077000332000	770-LM 33	46	43,9	28,0	6	180
077000342000	770-LM 34	46	44,9	29,0	6	195

Code	Number	l/mm	d1 mm	d2 mm	Pieces	Weight/g
0770100172000	770-LA 5/16	40	12,2	23,0	6	56
0770100182000	770-LA 11/32	40	12,8	23,0	6	56
0770100192000	770-LA 3/8	40	13,9	23,0	6	56
0770100202000	770-LA 13/32	40	15,0	23,0	6	56
0770100212000	770-LA 7/16	40	16,3	23,0	6	56
0770100232000	770-LA 1/2	40	18,4	23,0	6	60
0770100242000	770-LA 9/16	40	20,2	23,0	6	62
0770100252000	770-LA 19/32	40	21,5	23,0	6	62
0770100262000	770-LA 5/8	40	22,7	23,0	6	66
0770100262001	770-LA 21/32	40	24,0	23,0	6	66
0770100272000	770-LA 11/16	40	24,7	23,0	6	66
0770100282000	770-LA 3/4	40	26,5	23,0	6	66
0770100292000	770-LA 25/32	40	27,8	23,0	6	72
0770100302000	770-LA 13/16	40	28,4	23,6	6	76
0770100312000	770-LA 7/8	40	30,5	24,0	6	84
0770100322000	770-LA 15/16	42	32,4	23,4	6	92
0770100332000	770-LA 31/32	42	33,3	25,1	6	106
0770100342000	770-LA 1	42	34,3	25,3	6	112
0770100352000	770-LA 1.1/16	44	36,5	26,2	6	130
0770100362000	770-LA 1.1/8	44	38,4	27,2	6	150
0770100372000	770-LA 1.3/16	44	40,1	28,0	6	160
0770100382000	770-LA 1.1/4	46	42,6	28,0	6	170
0770100392000	770-LA 1.5/16	46	44,9	29,0	6	180



Code	Number	l/mm	d1 mm	d2 mm	Pieces	Weight/g
0770200062000	770-LW 1/8	40	12,8	23,0	6	56
0770200092000	770-LW 3/16	40	16,3	23,0	6	58
0770200132000	770-LW 1/4	40	19,4	23,0	6	60
0770200172000	770-LW 5/16	40	21,5	23,0	6	62
0770200192000	770-LW 3/8	40	25,3	23,0	6	64
0770200212000	770-LW 7/16	40	28,8	24,0	6	78
0770200232000	770-LW 1/2	40	31,7	25,2	6	90
0770200242000	770-LW 9/16	42	34,7	25,7	6	108
0770200262000	770-LW 5/8	44	37,5	27,2	6	140
0770200272000	770-LW 11/16	46	40,7	27,0	6	170
0770200282000	770-LW 3/4	46	43,9	28,0	6	180

771-LM.../771-LA...

SOCKET 1/2", HEXAGON

- hot forged
- chrome-plated, polished
- knurled
- ELORA-Chrome-Vanadium 31CrV3 / 1.2208
- female square according to DIN 3120-C 12,5, ISO 1174, with ball retaining groove
- according to DIN 3124, ISO 2725-1



1/2"

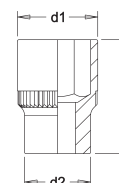

Code	Number	l/mm	d1 mm	d2 mm	Pieces	Weight/g
0771000052000	771-LM 5	40	8,2	23,0	6	56
0771000052001	771-LM 5,5	40	9,0	23,0	6	56
0771000062000	771-LM 6	40	9,4	23,0	6	56
0771000072000	771-LM 7	40	11,0	23,0	6	56
0771000082000	771-LM 8	40	12,0	23,0	6	56
0771000092000	771-LM 9	40	13,4	23,0	6	56
0771000102000	771-LM 10	40	15,1	23,0	6	56
0771000112000	771-LM 11	40	16,3	23,0	6	58
0771000122000	771-LM 12	40	17,7	23,0	6	58
0771000132000	771-LM 13	40	18,7	23,0	6	58
0771000142000	771-LM 14	40	20,2	23,0	6	60
0771000152000	771-LM 15	40	21,5	23,0	6	62
0771000162000	771-LM 16	40	22,7	23,0	6	66
0771000172000	771-LM 17	40	24,1	23,0	6	66
0771000182000	771-LM 18	40	25,3	23,0	6	66
0771000192000	771-LM 19	40	26,5	23,0	6	66
0771000202000	771-LM 20	40	27,8	23,0	6	72
0771000212000	771-LM 21	40	28,8	24,0	6	74
0771000222000	771-LM 22	40	30,2	23,7	6	86
0771000232000	771-LM 23	40	31,2	24,7	6	88
0771000242000	771-LM 24	40	32,6	24,8	6	96
0771000252000	771-LM 25	42	33,8	26,1	6	106
0771000262000	771-LM 26	42	35,2	24,9	6	108
0771000272000	771-LM 27	44	36,5	26,2	6	126
0771000282000	771-LM 28	44	37,5	27,2	6	140
0771000292000	771-LM 29	44	38,9	27,7	6	145
0771000302000	771-LM 30	44	40,1	28,0	6	150
0771000322000	771-LM 32	46	42,6	28,0	6	180
0771000332000	771-LM 33	46	43,9	28,0	6	180
0771000342000	771-LM 34	46	44,9	29,0	6	195
0771000362000	771-LM 36	55	49,0	32,0	6	275

Code	Number	l/mm	d1 mm	d2 mm	Pieces	Weight/g
0771100132000	771-LA 1/4	40	10,0	23,0	6	56
0771100172000	771-LA 5/16	40	12,2	23,0	6	56
0771100192000	771-LA 3/8	40	13,9	23,0	6	56
0771100212000	771-LA 7/16	40	16,3	23,0	6	56
0771100232000	771-LA 1/2	40	18,7	23,0	6	60
0771100242000	771-LA 9/16	40	20,2	23,0	6	62
0771100252000	771-LA 19/32	40	21,5	23,0	6	62
0771100262000	771-LA 5/8	40	22,7	23,0	6	66
0771100272000	771-LA 11/16	40	24,7	23,0	6	66
0771100282000	771-LA 3/4	40	26,5	23,0	6	66
0771100292000	771-LA 25/32	40	27,8	23,0	6	72
0771100302000	771-LA 13/16	40	28,4	23,6	6	76
0771100312000	771-LA 7/8	40	30,5	24,0	6	84
0771100322000	771-LA 15/16	42	32,4	24,6	6	92
0771100332000	771-LA 31/32	42	33,3	25,5	6	106
0771100342000	771-LA 1	42	34,3	26,1	6	112
0771100352000	771-LA 1.1/16	44	36,5	26,2	6	130
0771100362000	771-LA 1.1/8	44	38,4	27,2	6	150
0771100372000	771-LA 1.3/16	44	40,1	28,0	6	160
0771100382000	771-LA 1.1/4	46	42,6	28,0	6	170

You will find the matching socket rails on page no. 161



You will find the matching 1/2" plastic holder and additional accessories on page no. 162



770-LT..., 770-LTA...

SOCKET 1/2", EXTRA DEEP, BI-HEXAGON

- especially suitable for deep-set female screws on long threaded bolts
- hot forged
- chrome-plated, polished
- knurled
- ELORA-Chrome-Vanadium 31CrV3 / 1.2208
- female square according to DIN 3120-C 12,5, ISO 1174, with ball retaining groove
- according to DIN 3124, ISO 2725-1

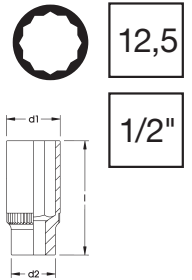

Code	Number	l/mm	d1 mm	d2 mm	Pieces	Weight/g
0770031002000	770-LT 10	80	15,1	23,0	6	104
0770031102000	770-LT 11	80	16,3	23,0	6	106
0770031202000	770-LT 12	80	17,7	23,0	6	108
0770031302000	770-LT 13	80	18,9	23,0	6	122
0770031402000	770-LT 14	80	20,2	23,0	6	130
0770031502000	770-LT 15	80	21,5	23,5	6	130
0770031602000	770-LT 16 / 5/8	80	22,7	24,0	6	130
0770031702000	770-LT 17	80	24,0	23,0	6	135
0770031802000	770-LT 18	80	25,5	23,0	6	155
0770031902000	770-LT 19 / 3/4	80	26,6	23,0	6	155
0770032102000	770-LT 21	80	29,1	23,5	6	185
0770032202000	770-LT 22	80	30,4	24,0	6	190
0770032402000	770-LT 24	80	32,9	24,3	6	220
0770032702000	770-LT 27 / 1.1/16	80	36,0	26,3	6	235
0770033002000	770-LT 30	80	40,5	28,0	6	275
0770033202000	770-LT 32	80	43,0	29,0	6	325
0770033402000	770-LT 34	80	46,0	29,0	6	350

Code	Number	l/mm	d1 mm	d2 mm	Pieces	Weight/g
0770132302000	770-LTA 1/2	80	18,9	23,0	6	130
0770132402000	770-LTA 9/16	80	20,2	23,0	6	130
0770031602000	770-LT 16 / 5/8	80	22,7	24,0	6	130
0770132702000	770-LTA 11/16	80	24,4	23,0	6	140
0770031902000	770-LT 19 / 3/4	80	26,6	23,0	6	155
0770133002000	770-LTA 13/16	80	29,1	23,5	6	185
0770133202000	770-LTA 15/16	80	32,9	24,3	6	220
0770133402000	770-LTA 1	80	34,4	25,0	6	235
0770032702000	770-LT 27 / 1.1/16	80	36,0	26,3	6	235

771-LT..., 771-LTA...

SOCKET 1/2", EXTRA DEEP, HEXAGON

- especially suitable for deep-set female screws on long threaded bolts
- hot forged
- chrome-plated, polished
- knurled
- ELORA-Chrome-Vanadium 31CrV3 / 1.2208
- female square according to DIN 3120-C 12,5, ISO 1174, with ball retaining groove
- according to DIN 3124, ISO 2725-1

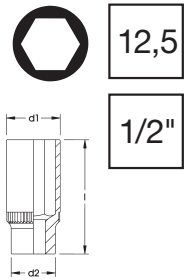

Code	Number	l/mm	d1 mm	d2 mm	Pieces	Weight/g
0771031001000	771-LT 10	80	15,1	23,0	6	104
0771031101000	771-LT 11	80	16,3	23,0	6	106
0771031201000	771-LT 12	80	17,7	23,0	6	108
0771031301000	771-LT 13	80	18,9	23,0	6	122
0771031401000	771-LT 14	80	20,2	23,0	6	130
0771031501000	771-LT 15	80	21,5	23,5	6	130
0771031601000	771-LT 16	80	22,7	24,0	6	130
0771031701000	771-LT 17	80	24,0	23,0	6	135
0771031801000	771-LT 18	80	25,5	23,0	6	155
0771031901000	771-LT 19	80	26,6	23,0	6	155
0771032101000	771-LT 21	80	29,1	23,5	6	185
0771032201000	771-LT 22	80	30,4	24,0	6	190
0771033802000	771-LT 38 / 1.1/2	80	51,5	27,5	6	375

Code	Number	l/mm	d1 mm	d2 mm	Pieces	Weight/g
0771133001000	771-LTA13/16	80	29,1	23,5	6	185
0771132701000	771-LTA11/16	80	24,4	23,0	6	155
0771033802000	771-LT 38 / 1.1/2	80	51,5	27,5	6	375

770-LTXE...

SOCKET 1/2"

- for outside TORX® screws
- hot forged
- chrome-plated, polished
- knurled
- ELORA-Chrome-Vanadium 31CrV3 / 1.2208
- female square according to DIN 3120-C 12,5, ISO 1174, with ball retaining groove
- TORX® = reg. trademark of Acument Intellectual Properties, LLC. USA

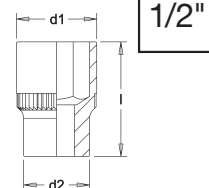

03

Code	Number	★ mm	l/mm	d1 mm	d2 mm	Pieces	Weight/g
0770036102000	770-LTXE 10	9,42	36	15,0	23,0	6	50
0770036112000	770-LTXE 11	10,08	36	15,0	23,0	6	53
0770036122000	770-LTXE 12	11,17	36	17,0	22,0	6	56
0770036142000	770-LTXE 14	12,90	36	19,0	22,0	6	59
0770036162000	770-LTXE 16	14,76	36	21,0	22,0	6	60
0770036182000	770-LTXE 18	16,70	38	21,0	25,0	6	78
0770036202000	770-LTXE 20	18,45	38	24,0	25,0	6	86
0770036242000	770-LTXE 24	22,16	38	28,0	25,0	6	104



You will find the matching spark plug sockets on page no. 440



770-L16-17-18

SCREWDRIVER SOCKET 1/2"

- for plain slotted screws
- chrome-plated, polished
- ELORA-Chrome-Vanadium 31CrV3 / 1.2208
- female square according to DIN 3120-C 12,5, ISO 1174
- with ball retaining groove

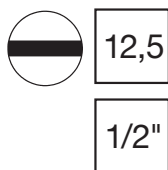

Code	Number	Blade Size mm	l/mm	Pieces	Weight/g
0770016002000	770-L16	24 x 4,0	43	6	86
0770017002000	770-L17	19 x 3,0	43	6	62
0770018002000	770-L18	13 x 2,0	43	6	60

3200-IS...

SCREWDRIVER SOCKET 1/2"

- for plain slotted screws
- chrome-plated, polished
- knurled
- holder made of ELORA-Chrome-Vanadium 31CrV3 / 1.2208
- female square according to DIN 3120-C 12,5, ISO 1174, with ball retaining groove
- blade made of ELORA-Vanadium special steel, gunmetal finished
- blade according to DIN ISO 2380-1 Form B

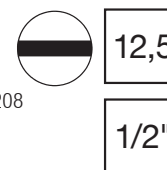

Code	Number	l/mm	l1 mm	d mm	Pieces	Weight/g
3200012082000	3200-IS 1,2x8	62	23,0	23,0	6	80
3200016082000	3200-IS 1,6x8	62	23,0	23,0	6	80
3200016102000	3200-IS 1,6x10	62	23,0	23,0	6	90
3200020122000	3200-IS 2,0x12	62	23,0	23,0	6	120
3200025142000	3200-IS 2,5x14	62	23,0	23,0	6	125

3220-PH...

SCREWDRIVER SOCKET 1/2"

- for cross slotted screws
- chrome-plated, polished
- knurled
- holder made of ELORA-Chrome-Vanadium 31CrV3 / 1.2208
- female square according to DIN 3120-C 12,5, ISO 1174, with ball retaining groove
- blade made of ELORA-Vanadium special steel, gunmetal finished
- blade according to DIN ISO 8764-1 PH



Code	Number	Blade Size mm	l/mm	l1 mm	d mm	Pieces	Weight/g
3220000022000	3220-PH2	3,1-5,2	56	17,0	23,0	6	75
3220000032000	3220-PH3	5,3-7,2	56	17,0	23,0	6	75
3220000042000	3220-PH4	7,3-12,7	56	17,0	23,0	6	80

3225-PZ...

SCREWDRIVER SOCKET 1/2"

- for cross slotted screws
- chrome-plated, polished
- knurled
- holder made of ELORA-Chrome-Vanadium 31CrV3 / 1.2208
- female square according to DIN 3120-C 12,5, ISO 1174, with ball retaining groove
- blade made of ELORA-Vanadium special steel, gunmetal finished
- blade according to DIN ISO 8764-1 PZ

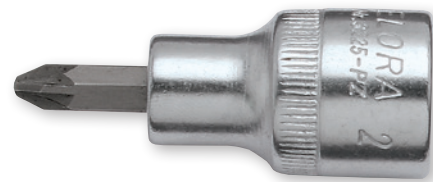

Code	Number	Blade Size mm	l/mm	l1 mm	d mm	Pieces	Weight/g
3225000022000	3225-PZ2	5-10	56	17,0	23,0	6	70
3225000032000	3225-PZ3	12-16	56	17,0	23,0	6	75
3225000042000	3225-PZ 4	18 ->	56	17,0	23,0	6	80

3210-IN..., 3210-INA...

SCREWDRIVER SOCKET 1/2"

- for inside hexagon screws
- chrome-plated, polished
- knurled
- holder made of ELORA-Chrome-Vanadium 31CrV3 / 1.2208
- female square according to DIN 3120-C 12,5, ISO 1174, with ball retaining groove
- blade made of ELORA-Vanadium special steel, gunmetal finished
- according to DIN 7422

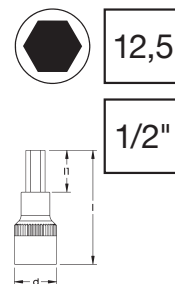

Code	Number	mm	l/mm	l1 mm	d mm	Pieces	Weight/g	Code	Number	l/mm	l1 mm	d mm	Pieces	Weight/g
321000042000	3210-IN 4	M5	60	22,0	23,0	6	65	3210100092000	3210-INA 3/16	52	14,0	23,0	6	75
3210000052000	3210-IN 5	M6	60	22,0	23,0	6	70	3210100112000	3210-INA 7/32	52	14,0	23,0	6	75
3210000062000	3210-IN 6	M8	60	22,0	23,0	6	75	3210100132000	3210-INA 1/4	52	14,0	23,0	6	75
3210000072000	3210-IN 7		60	22,0	23,0	6	85	3210100172000	3210-INA 5/16	52	14,0	23,0	6	75
3210000082000	3210-IN 8	M10	60	22,0	23,0	6	80	3210100192000	3210-INA 3/8	52	14,0	23,0	6	96
3210000092000	3210-IN 9		60	22,0	23,0	6	90	3210100212000	3210-INA 7/16	52	14,0	23,0	6	105
3210000102000	3210-IN 10	M12	60	22,0	23,0	6	90	3210100232000	3210-INA 1/2	52	14,0	23,0	6	110
3210000122000	3210-IN 12	M14	60	22,0	23,0	6	115	3210100242000	3210-INA 9/16	60	20,0	24,0	6	140
3210000142000	3210-IN 14	M16	60	22,0	23,0	6	120	3210100262000	3210-INA 5/8	60	20,0	24,0	6	160
3210000172000	3210-IN 17	M20	60	20,0	24,0	6	160	3210100282000	3210-INA 3/4	60	20,0	24,0	6	205
3210000192000	3210-IN 19	M24	60	20,0	24,0	6	205							
3210000222000	3210-IN 22	M30	60	20,0	24,0	6	227							

3210-INL...

SCREWDRIVER SOCKET 1/2", LONG

- for inside hexagon screws
- chrome-plated, polished
- knurled
- holder made of ELORA-Chrome-Vanadium 31CrV3 / 1.2208
- female square according to DIN 3120-C 12,5, ISO 1174, with ball retaining groove
- blade made of ELORA-Vanadium special steel, gunmetal finished
- according to DIN 7422

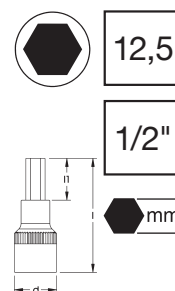

Code	Number	mm	l/mm	l1 mm	d mm	Pieces	Weight/g
3210010052100	3210-INL 5x100	M6	100	62,0	23,0	6	90
3210010052180	3210-INL 5x180	M6	180	142,0	23,0	6	110
3210010062070	3210-INL 6x70	M8	70	32,0	23,0	6	90
3210010062100	3210-INL 6x100	M8	100	62,0	23,0	6	100
3210010062137	3210-INL 6x137	M8	137	99,0	23,0	6	120
3210010062160	3210-INL 6x160	M8	160	122,0	23,0	6	135
3210010062220	3210-INL 6x220	M8	220	182,0	23,0	6	145
3210010072100	3210-INL 7x100	-	100	62,0	23,0	6	90
3210010082083	3210-INL 8x83	M10	83	45,0	23,0	6	90
3210010082100	3210-INL 8x100	M10	100	62,0	23,0	6	100
3210010082120	3210-INL 8x120	M10	120	82,0	23,0	6	120
3210010102140	3210-INL 10x140	M12	140	102,0	23,0	6	140
3210010122140	3210-INL 12x140	M14	140	102,0	23,0	6	180
3210010142140	3210-INL 14x140	M16	140	102,0	23,0	6	240
3210010172100	3210-INL 17x100	M20	100	60,0	24,0	6	230
3210010192100	3210-INL 19x100	M24	100	60,0	24,0	6	295

3210-KUL...

SCREWDRIVER SOCKET 1/2" WITH BALL END, LONG

- for inside hexagon screws
- maximum swivel angle 15°
- chrome-plated, polished
- knurled
- holder made of ELORA-Chrome-Vanadium 31CrV3 / 1.2208
- female square according to DIN 3120-C 12,5, ISO 1174, with ball retaining groove
- blade made of ELORA-Vanadium special steel, gunmetal finished

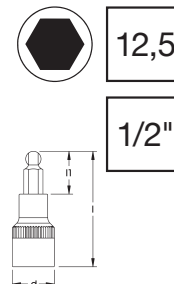

Code	Number	mm	l/mm	l1 mm	d mm	Pieces	Weight/g
3210020052140	3210-KUL 5	M6	140	102,0	23,0	6	110
3210020062140	3210-KUL 6	M8	140	102,0	23,0	6	120
3210020072140	3210-KUL 7		140	102,0	23,0	6	130
3210020082140	3210-KUL 8	M10	140	102,0	23,0	6	130
3210020102140	3210-KUL 10	M12	140	102,0	23,0	6	140
3210020122140	3210-KUL 12	M14	140	102,0	23,0	6	180

3210-INZ...

SCREWDRIVER SOCKET 1/2", LONG

- for inside hexagon screws with bore hole
- with pin for IC-screws
- chrome-plated, polished
- knurled
- holder made of ELORA-Chrome-Vanadium 31CrV3 / 1.2208
- female square according to DIN 3120-C 12,5, ISO 1174, with ball retaining groove
- blade made of ELORA-Vanadium special steel, gunmetal finished

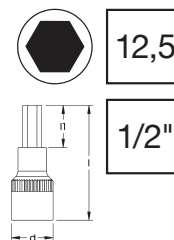

Code	Number	mm	l/mm	l1 mm	d mm	Pieces	Weight/g
3210050052000	3210-INZ 5	M6	60	22,0	23,0	6	65
3210050062000	3210-INZ 6	M8	60	22,0	23,0	6	75
3210050082000	3210-INZ 8	M10	60	22,0	23,0	6	80
3210050102000	3210-INZ 10	M12	60	22,0	23,0	6	90
3210050122000	3210-INZ 12	M14	60	22,0	23,0	6	115
3210050142000	3210-INZ 14	M16	60	22,0	23,0	6	120

3245-TX...

SCREWDRIVER SOCKET 1/2"

- for inside TORX® screws
- chrome-plated, polished
- knurled
- holder made of ELORA-Chrome-Vanadium 31CrV3 / 1.2208
- female square according to DIN 3120-C 12,5, ISO 1174, with ball retaining groove
- blade made of ELORA-Vanadium special steel, gunmetal finished
- TORX® = reg. trademark of Acument Intellectual Properties, LLC. USA

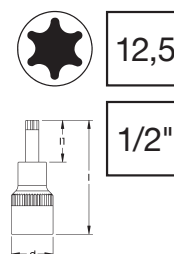

Code	Number	mm	l/mm	l1 mm	d mm	Pieces	Weight/g
3245000201000	3245-TX 20	3,86	55	17,0	23,0	6	67
3245000251000	3245-TX 25	4,43	55	17,0	23,0	6	68
3245000271000	3245-TX 27	4,99	55	17,0	23,0	6	68
3245000301000	3245-TX 30	5,52	55	17,0	23,0	6	68
3245000401000	3245-TX 40	6,65	55	17,0	23,0	6	69
3245000451000	3245-TX 45	7,82	55	17,0	23,0	6	70
3245000501000	3245-TX 50	8,83	55	17,0	23,0	6	73
3245000551000	3245-TX 55	11,22	56	17,0	23,0	6	112
3245000601000	3245-TX 60	13,25	56	17,0	23,0	6	117

3245-TXL...

SCREWDRIVER SOCKET 1/2", LONG

- for inside TORX® screws
- chrome-plated, polished
- knurled
- holder made of ELORA-Chrome-Vanadium 31CrV3 / 1.2208
- female square according to DIN 3120-C 12,5, ISO 1174, with ball retaining groove
- blade made of ELORA-Vanadium special steel, gunmetal finished
- TORX® = reg. trademark of Acument Intellectual Properties, LLC. USA

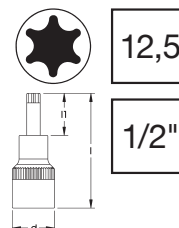

Code	Number	mm	l/mm	l1 mm	d mm	Pieces	Weight/g
3245010201100	3245-TXL 20	3,86	100	62,0	23,0	6	67
3245010251100	3245-TXL 25	4,43	100	62,0	23,0	6	68
3245010271100	3245-TXL 27	4,99	100	62,0	23,0	6	68
3245010301100	3245-TXL 30	5,52	100	62,0	23,0	6	68
3245010401100	3245-TXL 40	6,65	100	62,0	23,0	6	69
3245010451100	3245-TXL 45	7,82	100	62,0	23,0	6	70
3245010451140	3245-TXL 45x140	7,82	140	102,0	23,0	6	145
3245010501100	3245-TXL 50	8,83	100	62,0	23,0	6	73
3245010501000	3245-TXL 50x140	8,83	140	102,0	23,0	6	150
3245010551100	3245-TXL 55	11,22	100	62,0	23,0	6	112
3245010551000	3245-TXL 55x140	11,22	140	102,0	23,0	6	160
3245010601100	3245-TXL 60	13,25	100	62,0	23,0	6	117
3245010701140	3245-TXL 70x140	15,5	140	102,0	23,0	6	175

3245-TTX...

SCREWDRIVER SOCKET 1/2"

- for Inside-TORX® safety screws
- with bore hole in tip
- chrome-plated, polished
- knurled
- holder made of ELORA-Chrome-Vanadium 31CrV3 / 1.2208
- female square according to DIN 3120-C 12,5, ISO 1174, with ball retaining groove
- blade made of ELORA-Vanadium special steel, gunmetal finished
- TORX® = reg. trademark of Acument Intellectual Properties, LLC. USA

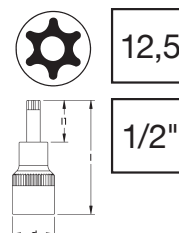

Code	Number	mm	l/mm	l1 mm	d mm	Pieces	Weight/g
3245020201000	3245-TTX 20	3,86	55	17,0	23,0	6	67
3245020251000	3245-TTX 25	4,43	55	17,0	23,0	6	68
3245020271000	3245-TTX 27	4,99	55	17,0	23,0	6	68
3245020301000	3245-TTX 30	5,52	55	17,0	23,0	6	68
3245020401000	3245-TTX 40	6,65	55	17,0	23,0	6	69
3245020451000	3245-TTX 45	7,82	55	17,0	23,0	6	70
3245020501000	3245-TTX 50	8,83	55	17,0	23,0	6	73
3245020551000	3245-TTX 55	11,22	56	17,0	23,0	6	112
3245020601000	3245-TTX 60	13,25	56	17,0	23,0	6	117

3230-XZN...

SCREWDRIVER SOCKET 1/2"

- for inside multi-point B & S and XZN screws
- chrome-plated, polished
- knurled
- holder made of ELORA-Chrome-Vanadium 31CrV3 / 1.2208
- female square according to DIN 3120-C 12,5, ISO 1174, with ball retaining groove
- blade made of ELORA-Vanadium special steel, gunmetal finished
- blade according to DIN 2325
- according to DIN 2324

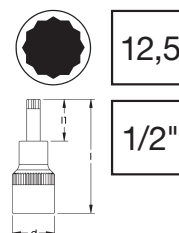

Code	Number	mm	l/mm	l1 mm	d mm	Pieces	Weight/g
3230000052000	3230-XZN 5	M5	52	14,0	23,0	6	75
3230000062000	3230-XZN 6	M6	52	14,0	23,0	6	75
3230000082000	3230-XZN 8	M8	53	15,0	23,0	6	80
3230000102000	3230-XZN 10	M10	53	15,0	23,0	6	85
3230000122000	3230-XZN 12	M12	55	17,0	23,0	6	115
3230000142000	3230-XZN 14	M14	58	20,0	23,0	6	120
3230000162000	3230-XZN 16	M16	60	20,0	24,0	6	152

3230-XZNL...

SCREWDRIVER SOCKET 1/2", EXTRA LONG

- ▶ for inside multi-point B & S and XZN screws
- ▶ chrome-plated, polished
- ▶ knurled
- ▶ holder made of ELORA-Chrome-Vanadium 31CrV3 / 1.2208
- ▶ female square according to DIN 3120-C 12,5, ISO 1174, with ball retaining groove
- ▶ blade made of ELORA-Vanadium special steel, gunmetal finished
- ▶ blade according to DIN 2325
- ▶ according to DIN 2324

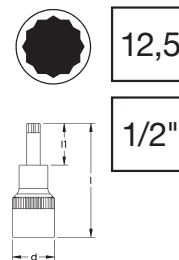

Code	Number	mm	l/mm	l1 mm	d mm	Pieces	Weight/g
3230010062100	3230-XZNL 6x100	M6	100	62,0	23,0	6	95
3230010082080	3230-XZNL 8x80	M8	80	42,0	23,0	6	85
3230010082100	3230-XZNL 8x100	M8	100	62,0	23,0	6	95
3230010082120	3230-XZNL 8x120	M8	120	82,0	23,0	6	100
3230010102100	3230-XZNL 10x100	M10	100	62,0	23,0	6	115
3230010102120	3230-XZNL 10x120	M10	120	82,0	23,0	6	135
3230010102140	3230-XZNL 10x140	M10	140	102,0	23,0	6	140
3230010122100	3230-XZNL 12x100	M12	100	62,0	23,0	6	160
3230010122140	3230-XZNL 12x140	M12	140	102,0	23,0	6	165
3230010142100	3230-XZNL 14x100	M14	100	62,0	23,0	6	165

3240-RIB...

SCREWDRIVER SOCKET 1/2"

- ▶ for RIBE®-CV-screws
- ▶ chrome-plated, polished
- ▶ knurled
- ▶ holder made of ELORA-Chrome-Vanadium 31CrV3 / 1.2208
- ▶ female square according to DIN 3120-C 12,5, ISO 1174, with ball retaining groove
- ▶ blade made of ELORA-Vanadium special steel, gunmetal finished
- ▶ RIBE® = reg. trademark of Richard Bergner GmbH & Co KG, Schwabach

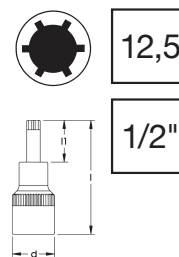

Code	Number	mm	l/mm	l1 mm	d mm	Pieces	Weight/g
3240000082000	3240-RIB 8	M8	63	25,0	23,0	6	80
3240000122000	3240-RIB 12	M12	63	25,0	23,0	6	120
3240000142000	3240-RIB 14	M14	63	25,0	23,0	6	135
3240000162000	3240-RIB 16	M16	63	23,0	24,0	6	130

770-KL/770-MKL

SOCKET RAIL 1/2"

770-KL:

- ▶ 15 shiftable socket clips
- ▶ two holes allow permanent mounting
- ▶ chrome-plated, polished

770-MKL:

- ▶ 14 shiftable socket clips
- ▶ strong magnet enables firm mounting
- ▶ black coated

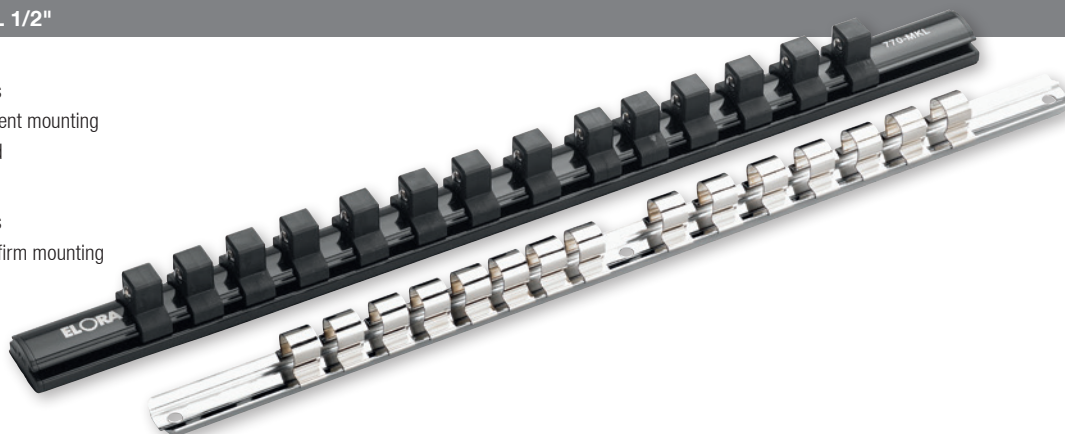

Code	Number	l/mm	Pieces	Weight/g
0000912146000	770-KL	414	6	80
0000912146001	770-MKL	420	6	269

770-L SB

PLASTIC HOLDER 1/2"

- ▶ appropriate for sockets nominal size 12,5 (1/2") and operation tools with female square



12,5

1/2"

Code	Number	Pieces	Weight/g
0000700127000	770-SB	1	10

770/771-LSP1...

SOCKET DISPLAY DISPENSER

- ▶ heavy gauge sheet steel, black lacquered
- ▶ sockets: knurled, chrome-plated, polished, with ball retaining groove
- ▶ sockets: Chrome-Vanadium 31CrV3 / 1.2208
- ▶ sockets: 1/2" square drive according to DIN 3120/ ISO 1174, for manual drive, sizes according to DIN 3124/ ISO 2725



12,5

1/2"

mm
AF"

Code	Number	Width mm	Depth mm	Height mm	Contents	Pieces	Weight/g
0770510002000	770-LSP1M	605	380	55	Bi-Hexagon Sockets 770-LM 16 pcs. each 10, 11, 12, 13, 14, 15, 16 mm 15 pcs. 17 mm 14 pcs. each 18, 19 mm 13 pcs. 20 mm 12 pcs. each 21, 22 mm 11 pcs. 24 mm 10 pcs. each 26, 27 mm 9 pcs. 30 mm 8 pcs. 32 mm	1	26000
0771510002000	771-LSP1M	605	380	55	Hexagon Sockets 771-LM 16 pcs. each 10, 11, 12, 13, 14, 15, 16 mm 15 pcs. 17 mm 14 pcs. each 18, 19 mm 13 pcs. 20 mm 12 pcs. each 21, 22 mm 11 pcs. 24 mm 10 pcs. each 26, 27 mm 9 pcs. 30 mm 8 pcs. 32 mm	1	26000
0770610002000	770-LSP1A	605	380	55	Bi-Hexagon Sockets 770-LA 16 pcs. each 3/8, 7/16 AF 32 pcs. each 1/2, 9/16 AF 16 pcs. each 19/32, 5/8 AF 15 pcs. 11/16 AF 14 pcs. 3/4 AF 13 pcs. each 25/32, 13/16 AF 12 pcs. 7/8 AF 11 pcs. 15/16 AF 10 pcs. each 1, 1.1/16 AF 9 pcs. 1.1/8 AF 8 pcs. 1.1/4 AF	1	26000
0770510102000	770-LSP1L	605	380	55	Socket Display Dispenser, empty	1	620

770/771-LSP2...

SOCKET DISPLAY DISPENSER

- ▶ heavy gauge sheet steel, black lacquered
- ▶ sockets: knurled, chrome-plated, polished, with ball retaining groove
- ▶ sockets: Chrome-Vanadium 31 CrV 3, Code-No. 1.2208
- ▶ sockets: 1/2" square drive according to DIN 3120/ ISO 1174, for manual drive, sizes according to DIN 3124/ ISO 2725

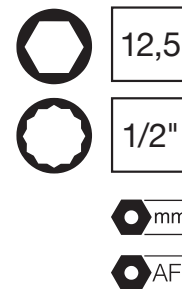

Code	Number	Width mm	Depth mm	Height mm	Contents	Pieces	Weight/g
0770510012000	770-LSP2M	410	135	55	Bi-Hexagon Sockets 770-LM 10 pcs. each 10, 11, 12, 13, 14 mm 9 pcs. 17 mm 8 pcs. 19 mm 7 pcs. each 22, 24 mm 6 pcs. 27 mm 5 pcs. each 30, 32 mm	1	10000
0771510012000	771-LSP2M	410	135	55	Hexagon Sockets 771-LM 10 pcs. each 10, 11, 12, 13, 14 mm 9 pcs. 17 mm 8 pcs. 19 mm 7 pcs. each 22, 24 mm 6 pcs. 27 mm 5 pcs. each 30, 32 mm	1	10000
0770610012000	770-LSP2A	410	135	55	Bi-Hexagon Sockets 770-LA 10 pcs. each 3/8, 7/16, 1/2, 9/16, 5/8 AF 9 pcs. 11/16 AF 8 pcs. 3/4 AF 7 pcs. each 7/8, 15/16 AF 6 pcs. each 1, 1.1/16, 1.1/8 AF	1	10000
0770510112000	770-LSP2L	410	135	55	Socket Display Dispenser, empty	1	2270

770/771-KS1M

ELORA-BIG SPENDER

- ▶ for sockets 3/8 and 1/2 square drive
- ▶ BIG SPENDER 770-KS: with 30 dividers
- ▶ powder coated
- ▶ sockets: Chrome-Vanadium 31CrV3 / 1.2208
- ▶ sockets: 1/2" square drive according to DIN 3120/ ISO 1174, for manual drive, sizes according to DIN 3124/ ISO 2725



Code	Number	Width mm	Depth mm	Height mm	Contents	Pieces	Weight/g
0770510312000	770-KS1M	470	320	234	Bi-Hexagon Sockets 770-LM 6 pcs. each 8, 9, 10, 11, 12, 13, 14, 15, 16, 17, 18, 19, 20, 21, 22, 23, 24, 25, 26, 27, 28, 30, 32 mm 6 pcs. 770-L11 Socket Converter male 3/4 female 1/2 6 pcs. 770-L13 Socket Converter male 3/8 female 1/2	1	22000
0771510312000	771-KS1M	470	320	234	Hexagon Sockets 771-LM 6 pcs. each 8, 9, 10, 11, 12, 13, 14, 15, 16, 17, 18, 19, 20, 21, 22, 23, 24, 25, 26, 27, 28, 30, 32 mm 6 pcs. 770-L11 Socket Converter male 3/4 female 1/2 6 pcs. 770-L13 Socket Converter male 3/8 female 1/2	1	20500
0770510306000	770-KS	470	320	234	Pin-up Tray, empty	1	8500

770-KS.../AS...

ELORA-BIG SPENDER

- BIG SPENDER: with 2 trays and 30 zinc plated tray dividers
- black powder coated
- pin-up tray: with 16 zinc plated tray dividers
- black powder coated
- sockets: knurled, chrome-plated, polished, with ball retaining groove
- sockets: Chrome-Vanadium 31CrV3 / 1.2208
- sockets: 1/2" square drive according to DIN 3120/ ISO 1174, for manual drive, sizes according to DIN 3124/ ISO 2725

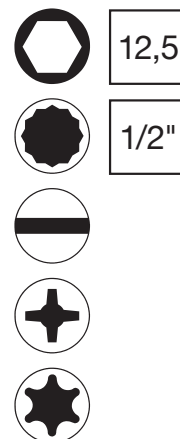

Code	Number	Width mm	Depth mm	Height mm	Contents	Pieces	Weight/g
0770510322000	770-KS2M	474	320	270	6 pcs. each Hexagon Screwdriver Socket 3210-IN 4, 5, 6, 7, 8, 9, 10, 12, 14, 17, 19 mm TORX®-Screwdriver Socket 3245-TX 20, 25, 27, 30, 40, 45, 50, 55, 60 mm XZN-B&S Screwdriver Socket 3230-XZN 5, 6, 8, 10, 12, 14 mm Screwdriver Socket cross slotted 3220-PH3 Screwdriver Socket plain slotted 3200-IS 1,6x10 mm	1	24000
0770510422000	770-AS2M	474	320	270	5 pcs. each Hexagon Screwdriver Socket 3210-INL 5x100, 6x70, 6x100, 7x100, 8x83, 8x100, 10x140 mm TORX®-Screwdriver Socket 3245-TXL 50, 55 mm XZN-B&S Screwdriver Socket 3230-XZNL 6x100, 8x100, 10x100, 12x100, 14x100 mm	1	10300
0770510406000	770-AS	474	320	270	pin up top tray , empty	1	2000

You will find the matching 1/2" socket converter on page no. 166



770-L9/770-L10...

FLEXIBLE HANDLE 1/2"

- nonslip QUATROLIT®-2C-handle
- with suspension hole
- matt chrome-plated
- ELORA-Chrome-Vanadium 31CrV3 / 1.2208
- male square according to DIN 3120-A 12,5, ISO 1174, with ball locking device
- according to DIN 3122, ISO 3315



12,5

1/2"

Code	Number	l/mm	Pieces	Weight/g
0770009002000	770-L9	250	3	450
0770010002000	770-L10A	390	3	635
0770010012000	770-L10B	450	3	770

770-L3

SLIDING T-BAR 1/2"

- chrome-plated
- ELORA-Chrome-Vanadium 31CrV3 / 1.2208
- male square according to DIN 3120-A 12,5, ISO 1174, with ball locking device
- according to DIN 3122, ISO 3315



12,5

1/2"

Code	Number	l/mm	Pieces	Weight/g
0770003002000	770-L3	300	4	445

770-L8

OFFSET HANDLE 1/2"

- matt chrome-plated
- ELORA-Chrome-Vanadium 31CrV3 / 1.2208
- male square according to DIN 3120-A 12,5, ISO 1174, with ball locking device
- according to DIN 3122, ISO 3315



12,5

1/2"

Code	Number	l/mm	Pieces	Weight/g
0770008002000	770-L8	190	6	220

770-L2

SPEED BRACE 1/2"

- plastic handle
- matt chrome-plated
- ELORA-Chrome-Vanadium 31CrV3 / 1.2208
- male square according to DIN 3120-A 12,5, ISO 1174, with ball locking device
- according to DIN 3122, ISO 3315



12,5

1/2"

Code	Number	l/mm	Pieces	Weight/g
0770002002000	770-L2	380	6	615

770-L35-L66

EXTENSION BAR 1/2"

- chrome-plated, head polished
- ELORA-Chrome-Vanadium 31CrV3 / 1.2208
- square drive according to DIN 3120, ISO 1174, with ball locking device resp. hole
- according to DIN 3123, ISO 3316

12,5

1/2"



Code	Number	l/mm	Pieces	Weight/g
0770003502000	770-L35	50	6	90
0770004002000	770-L4	75	6	125
0770005002000	770-L5	125	6	190
0770006002000	770-L6	250	6	325
0770006602000	770-L66	500	6	910

770-L...V

EXTENSION BAR 1/2", SWIVELLING

- with special square for a swivel angle of 12,5° to each side
- especially suitable for screw connections within confined spaces
- ELORA-Chrome-Vanadium 31CrV3 / 1.2208
- square drive according to DIN 3120, ISO 1174, with ball locking device resp. hole

12,5

1/2"



Code	Number	l/mm	Pieces	Weight/g
0770004002100	770-L4V	75	6	125
0770005002100	770-L5V	125	6	190
0770005502100	770-L55V	150	6	220
0770006002100	770-L6V	250	6	330

770-L7

UNIVERSAL JOINT 1/2"

- chrome-plated, polished
- ELORA-Chrome-Vanadium 31CrV3 / 1.2208
- square drive according to DIN 3120, ISO 1174, with ball retaining groove resp. with ball locking device
- according to DIN 3123, ISO 3316

12,5

1/2"



Code	Number	l/mm	Pieces	Weight/g
0770007002000	770-L7	75	6	145

770-L..., 770-S9

SOCKET CONVERTER

- chrome-plated
- ELORA-Chrome-Vanadium 31CrV3 / 1.2208
- square drive according to DIN 3120, ISO 1174,
- according to DIN 3123, ISO 3316

12,5

1/2"



Code	Number	□	○	l/mm	Pieces	Weight/g
0770011002000	770-L11	3/4"	1/2"	45	6	130
0770020902000	770-S9	1/2"	3/4"	57	6	185
0770013002000	770-L13	3/8"	1/2"	40	6	65
0770014002000	770-L14	1/2"	3/8"	36	6	60

You will find the matching radiator drain socket on page no. 436



You will find the matching drain plug wrench on page no. 436



714-6MU

SOCKET SET 1/4" AND 1/2", COMBINED

- 25 pcs.
- in black metal storage case with plastic insert
- square drive according to DIN 3120, ISO 1174
- operation tools according to DIN 3122, ISO 3315



03

Code	Number	Ratchet	Sockets	Accessories	Pieces	Weight/g
0714562502000	714-6MU	1/4": Reversible Ratchet 1450-1D 1/2": Reversible Ratchet 770-L1D	Hexagon Sockets 1/4": 1455-M 5,5, 6, 7, 8, 9, 10, 11, 12, 13 mm 1/2": 771-LM 10, 13, 15, 17, 19, 22, 24, 27 mm	1/4": Spinner Handle 1450-3 Extension Bar 100 mm 1450-5 Universal Joint 1450-8 1/2": Extension Bar 125 mm 770-L5 Extension Bar 250 mm 770-L6 Universal Joint 770-L7	1	3700

714-6MU OMS

SOCKET SET 1/4" AND 1/2", COMBINED

- 46 pcs.
- in black metal storage case with OMS-hard foam insert
- square drive according to DIN 3120, ISO 1174
- operation tools according to DIN 3122, ISO 3315

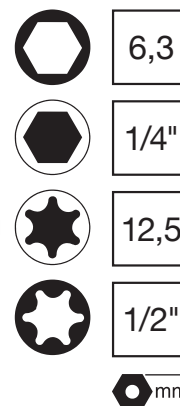

Code	Number	Ratchet	Sockets	Accessories	Pieces	Weight/g
0714562502046	714-6MU OMS	1/4": Reversible Ratchet 1450-1D 1/2": Reversible Ratchet 770-L1D	Sockets 1/4" 1455-M 5,5, 6, 7, 8, 9, 10, 11, 12, 13 mm 1455-TXE 4, 5, 6, 7, 8, 10, 11 Hexagon Sockets 1/2" 771-LM 10, 13, 15, 17, 19, 22, 24, 27 mm Screwdriver Sockets 1/4" 3243-TX 8, 9, 10, 15, 20, 25, 27, 30, 40 1455-IN 3, 4, 5, 6, 8 mm	1/4": Spinner Handle 1450-3 Extension Bar 100 mm 1450-5 Universal Joint 1450-8 1/2": Extension Bar 125 mm 770-L5 Extension Bar 250 mm 770-L6 Universal Joint 770-L7	1	3800

770-LK.../771-LK...

SOCKET SET 1/2"

- MU=15 pcs., AU=14 pcs.
- in black metal storage case with plastic insert
- square drive according to DIN 3120, ISO 1174
- operation tools according to DIN 3122, ISO 3315



Code	Number	Ratchet	Sockets	Accessories	Pieces	Weight/g
0770540402000	770-LKMU	Reversible Ratchet 770-L1D	Bi-Hexagon Sockets 770-LM 10, 11, 12, 13, 14, 15, 16,17, 18, 19, 20, 22 mm	Sliding T-Bar 770-L3 Extension Bar 250 mm 770-L6	1	4000
0771530302000	771-LKMU	Reversible Ratchet 770-L1D	Hexagon Sockets 771-LM 10, 11, 12, 13, 14, 15, 16,17, 18, 19, 20, 22 mm	Sliding T-Bar 770-L3 Extension Bar 250 mm 770-L6	1	4000
0770540402900	770-LKMK	Reversible Ratchet 770-L1K	Bi-Hexagon Sockets 770-LM 10, 11, 12, 13, 14, 15, 16,17, 18, 19, 20, 22 mm	Sliding T-Bar 770-L3 Extension Bar 250 mm 770-L6	1	3900
0771530302900	771-LKMK	Reversible Ratchet 770-L1K	Hexagon Sockets 771-LM 10, 11, 12, 13, 14, 15, 16,17, 18, 19, 20, 22 mm	Sliding T-Bar 770-L3 Extension Bar 250 mm 770-L6	1	3900
0770540412000	770-LKAU	Reversible Ratchet 770-L1D	Bi-Hexagon Sockets 770-LA 7/16, 1/2, 9/16, 19/32, 5/8, 11/16, 3/4, 13/16, 7/8, 15/16, 1 AF	Sliding T-Bar 770-L3 Extension Bar 250 mm 770-L6	1	2935
0771530342000	771-LKAU	Reversible Ratchet 770-L1D	Hexagon Sockets 771-LA 7/16, 1/2, 9/16, 19/32, 5/8, 11/16, 3/4, 13/16, 7/8, 15/16, 1 AF	Sliding T-Bar 770-L3 Extension Bar 250 mm 770-L6	1	3900
0770540412900	770-LKAK	Reversible Ratchet 770-L1K	Bi-Hexagon Sockets 770-LA 7/16, 1/2, 9/16, 19/32, 5/8, 11/16, 3/4, 13/16, 7/8, 15/16, 1 AF	Sliding T-Bar 770-L3 Extension Bar 250 mm 770-L6	1	2940
0771530342900	771-LKAK	Reversible Ratchet 770-L1K	Hexagon Sockets 771-LA 7/16, 1/2, 9/16, 19/32, 5/8, 11/16, 3/4, 13/16, 7/8, 15/16, 1 AF	Sliding T-Bar 770-L3 Extension Bar 250 mm 770-L6	1	3800

770-LIND.../771-LIND...

SOCKET SET 1/2"

- 19 pcs.
- in black metal storage case with plastic insert
- square drive according to DIN 3120, ISO 1174
- operation tools according to DIN 3122, ISO 3315

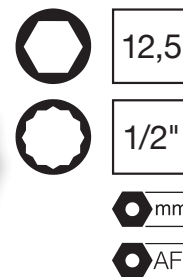

Code	Number	Ratchet	Sockets	Accessories	Pieces	Weight/g
0770530302100	770-LINDMF	Reversible Ratchet with safety locking 770-L1F	Bi-Hexagon Sockets 770-LM 10, 11, 12, 13, 14, 15, 16, 17, 19, 22, 24, 27, 30, 32 mm	Sliding T-Bar 770-L3 Extension Bar 125 mm 770-L5 Extension Bar 250 mm 770-L6 Universal Joint 770-L7	1	4300
0771520252000	771-LINDMF	Reversible Ratchet with safety locking 770-L1F	Hexagon Sockets 771-LM 10, 11, 12, 13, 14, 15, 16, 17, 19, 22, 24, 27, 30, 32 mm	Sliding T-Bar 770-L3 Extension Bar 125 mm 770-L5 Extension Bar 250 mm 770-L6 Universal Joint 770-L7	1	4300
0770530302000	770-LINDMU	Reversible Ratchet 770-L1D	Bi-Hexagon Sockets 770-LM 10, 11, 12, 13, 14, 15, 16, 17, 19, 22, 24, 27, 30, 32 mm	Sliding T-Bar 770-L3 Extension Bar 125 mm 770-L5 Extension Bar 250 mm 770-L6 Universal Joint 770-L7	1	4200
0771520202000	771-LINDMU	Reversible Ratchet 770-L1D	Hexagon Sockets 771-LM 10, 11, 12, 13, 14, 15, 16, 17, 19, 22, 24, 27, 30, 32 mm	Sliding T-Bar 770-L3 Extension Bar 125 mm 770-L5 Extension Bar 250 mm 770-L6 Universal Joint 770-L7	1	4300
0770530302900	770-LINDMK	Reversible Ratchet 770-L1K	Bi-Hexagon Sockets 770-LM 10, 11, 12, 13, 14, 15, 16, 17, 19, 22, 24, 27, 30, 32 mm	Sliding T-Bar 770-L3 Extension Bar 125 mm 770-L5 Extension Bar 250 mm 770-L6 Universal Joint 770-L7	1	4200
0771520262000	771-LINDMK	Reversible Ratchet 770-L1K	Hexagon Sockets 771-LM 10, 11, 12, 13, 14, 15, 16, 17, 19, 22, 24, 27, 30, 32 mm	Sliding T-Bar 770-L3 Extension Bar 125 mm 770-L5 Extension Bar 250 mm 770-L6 Universal Joint 770-L7	1	4200
0770530322100	770-LINDAF	Reversible Ratchet with safety locking 770-L1F	Bi-Hexagon Sockets 770-LA 3/8, 7/16, 1/2, 9/16, 19/32, 5/8, 11/16, 3/4, 13/16, 7/8, 1, 1.1/16, 1.1/8, 1.3/16, 1.1/4 AF	Sliding T-Bar 770-L3 Extension Bar 125 mm 770-L5 Extension Bar 250 mm 770-L6 Universal Joint 770-L7	1	4300
0771520272000	771-LINDAF	Reversible Ratchet with safety locking 770-L1F	Hexagon Sockets 771-LA 3/8, 7/16, 1/2, 9/16, 19/32, 5/8, 11/16, 3/4, 13/16, 7/8, 1, 1.1/16, 1.1/8, 1.1/4 AF	Sliding T-Bar 770-L3 Extension Bar 125 mm 770-L5 Extension Bar 250 mm 770-L6 Universal Joint 770-L7	1	4300
0770530322000	770-LINDAU	Reversible Ratchet 770-L1D	Bi-Hexagon Sockets 770-LA 3/8, 7/16, 1/2, 9/16, 19/32, 5/8, 11/16, 3/4, 13/16, 7/8, 1, 1.1/16, 1.1/8, 1.1/4 AF	Sliding T-Bar 770-L3 Extension Bar 125 mm 770-L5 Extension Bar 250 mm 770-L6 Universal Joint 770-L7	1	4400
0771520222000	771-LINDAU	Reversible Ratchet 770-L1D	Hexagon Sockets 771-LA 3/8, 7/16, 1/2, 9/16, 19/32, 5/8, 11/16, 3/4, 13/16, 7/8, 1, 1.1/16, 1.1/8, 1.1/4 AF	Sliding T-Bar 770-L3 Extension Bar 125 mm 770-L5 Extension Bar 250 mm 770-L6 Universal Joint 770-L7	1	4300
0770530322900	770-LINDAK	Reversible Ratchet 770-L1K	Bi-Hexagon Sockets 770-LA 3/8, 7/16, 1/2, 9/16, 19/32, 5/8, 11/16, 3/4, 13/16, 7/8, 1, 1.1/16, 1.1/8, 1.1/4 AF	Sliding T-Bar 770-L3 Extension Bar 125 mm 770-L5 Extension Bar 250 mm 770-L6 Universal Joint 770-L7	1	4200
0771520222900	771-LINDAK	Reversible Ratchet 770-L1K	Hexagon Sockets 771-LA 3/8, 7/16, 1/2, 9/16, 19/32, 5/8, 11/16, 3/4, 13/16, 7/8, 1, 1.1/16, 1.1/8, 1.1/4 AF	Sliding T-Bar 770-L3 Extension Bar 125 mm 770-L5 Extension Bar 250 mm 770-L6 Universal Joint 770-L7	1	4200

770-OK.../771-OK...

SOCKET SET 1/2"

- MU=25 pcs., AU=23 pcs.
- in black metal storage case with plastic insert
- square drive according to DIN 3120, ISO 1174
- operation tools according to DIN 3122, ISO 3315

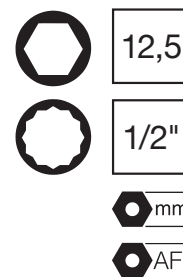

Code	Number	Ratchet	Sockets	Accessories	Pieces	Weight/g
0770530122000	770-OKLMU	Reversible Ratchet 770-L1D	Bi-Hexagon Sockets 770-LM 10, 11, 12, 13, 14, 15, 16,17, 18, 19, 20, 21, 22, 23, 24, 25, 26, 27, 30, 32 mm	Sliding T-Bar 770-L3 Extension Bar 125 mm 770-L5 Extension Bar 250 mm 770-L6 Universal Joint 770-L7	1	5200
0771520122000	771-OKLMU	Reversible Ratchet 770-L1D	Hexagon Sockets 771-LM 10, 11, 12, 13, 14, 15, 16,17, 18, 19, 20, 21, 22, 23, 24, 25, 26, 27, 30, 32 mm	Sliding T-Bar 770-L3 Extension Bar 125 mm 770-L5 Extension Bar 250 mm 770-L6 Universal Joint 770-L7	1	5200
0770530122900	770-OKLMK	Reversible Ratchet 770-L1K	Bi-Hexagon Sockets 770-LM 10, 11, 12, 13, 14, 15, 16,17, 18, 19, 20, 21, 22, 23, 24, 25, 26, 27, 30, 32 mm	Sliding T-Bar 770-L3 Extension Bar 125 mm 770-L5 Extension Bar 250 mm 770-L6 Universal Joint 770-L7	1	5100
0771520122900	771-OKLMK	Reversible Ratchet 770-L1K	Hexagon Sockets 771-LM 10, 11, 12, 13, 14, 15, 16,17, 18, 19, 20, 21, 22, 23, 24, 25, 26, 27, 30, 32 mm	Sliding T-Bar 770-L3 Extension Bar 125 mm 770-L5 Extension Bar 250 mm 770-L6 Universal Joint 770-L7	1	5100
0770530222000	770-OKLAU	Reversible Ratchet 770-L1D	Bi-Hexagon Sockets 770-LA 3/8, 7/16, 1/2, 9/16, 19/32, 5/8, 11/16, 3/4, 25/32, 13/16, 7/8, 15/16, 31/32, 1, 1.1/16, 1.1/8, 1.3/16 1.1/4 AF	Sliding T-Bar 770-L3 Extension Bar 125 mm 770-L5 Extension Bar 250 mm 770-L6 Universal Joint 770-L7	1	5100
0771520322000	771-OKLAU	Reversible Ratchet 770-L1D	Hexagon Sockets 771-LA 3/8, 7/16, 1/2, 9/16, 19/32, 5/8, 11/16, 3/4, 25/32, 13/16, 7/8, 15/16, 31/32, 1, 1.1/16, 1.1/8, 1.3/16 1.1/4 AF	Sliding T-Bar 770-L3 Extension Bar 125 mm 770-L5 Extension Bar 250 mm 770-L6 Universal Joint 770-L7	1	5100
0770530222900	770-OKLAK	Reversible Ratchet 770-L1K	Bi-Hexagon Sockets 770-LA 3/8, 7/16, 1/2, 9/16, 19/32, 5/8, 11/16, 3/4, 25/32, 13/16, 7/8, 15/16, 31/32, 1, 1.1/16, 1.1/8, 1.3/16 1.1/4 AF	Sliding T-Bar 770-L3 Extension Bar 125 mm 770-L5 Extension Bar 250 mm 770-L6 Universal Joint 770-L7	1	5000
0771520322900	771-OKLAK	Reversible Ratchet 770-L1K	Hexagon Sockets 771-LA 3/8, 7/16, 1/2, 9/16, 19/32, 5/8, 11/16, 3/4, 25/32, 13/16, 7/8, 15/16, 31/32, 1, 1.1/16, 1.1/8, 1.3/16 1.1/4 AF	Sliding T-Bar 770-L3 Extension Bar 125 mm 770-L5 Extension Bar 250 mm 770-L6 Universal Joint 770-L7	1	5000

770-LM.../771-LM...

SOCKET SET 1/2"

- MU=26 pcs., AU=24 pcs.
- in black metal storage case with plastic insert
- square drive according to DIN 3120, ISO 1174
- operation tools according to DIN 3122, ISO 3315



Code	Number	Ratchet	Sockets	Accessories	Pieces	Weight/g
0770530142000	770-LMF	Reversible Ratchet with safety locking 770-L1F	Bi-Hexagon Sockets 770-LM 10, 11, 12, 13, 14, 15, 16,17, 18, 19, 20, 21, 22, 23, 24, 25, 26, 27, 30, 32 mm	Speed Brace 770-L2 Sliding T-Bar 770-L3 Extension Bar 125 mm 770-L5 Extension Bar 250 mm 770-L6 Universal Joint 770-L7	1	5800
0771520152000	771-LMF	Reversible Ratchet with safety locking 770-L1F	Hexagon Sockets 771-LM 10, 11, 12, 13, 14, 15, 16,17, 18, 19, 20, 21, 22, 23, 24, 25, 26, 27, 30, 32 mm	Speed Brace 770-L2 Sliding T-Bar 770-L3 Extension Bar 125 mm 770-L5 Extension Bar 250 mm 770-L6 Universal Joint 770-L7	1	5800
0770530102000	770-LMU	Reversible Ratchet 770-L1D	Bi-Hexagon Sockets 770-LM 10, 11, 12, 13, 14, 15, 16,17, 18, 19, 20, 21, 22, 23, 24, 25, 26, 27, 30, 32 mm	Speed Brace 770-L2 Sliding T-Bar 770-L3 Extension Bar 125 mm 770-L5 Extension Bar 250 mm 770-L6 Universal Joint 770-L7	1	5900
0771520102000	771-LMU	Reversible Ratchet 770-L1D	Hexagon Sockets 771-LM 10, 11, 12, 13, 14, 15, 16,17, 18, 19, 20, 21, 22, 23, 24, 25, 26, 27, 30, 32 mm	Speed Brace 770-L2 Sliding T-Bar 770-L3 Extension Bar 125 mm 770-L5 Extension Bar 250 mm 770-L6 Universal Joint 770-L7	1	5800
0770530102900	770-LMK	Reversible Ratchet 770-L1K	Bi-Hexagon Sockets 770-LM 10, 11, 12, 13, 14, 15, 16,17, 18, 19, 20, 21, 22, 23, 24, 25, 26, 27, 30, 32 mm	Speed Brace 770-L2 Sliding T-Bar 770-L3 Extension Bar 125 mm 770-L5 Extension Bar 250 mm 770-L6 Universal Joint 770-L7	1	5700
0771520102900	771-LMK	Reversible Ratchet 770-L1K	Hexagon Sockets 771-LM 10, 11, 12, 13, 14, 15, 16,17, 18, 19, 20, 21, 22, 23, 24, 25, 26, 27, 30, 32 mm	Speed Brace 770-L2 Sliding T-Bar 770-L3 Extension Bar 125 mm 770-L5 Extension Bar 250 mm 770-L6 Universal Joint 770-L7	1	5700
0770530242000	770-LAF	Reversible Ratchet with safety locking 770-L1F	Bi-Hexagon Sockets 770-LA 3/8, 7/16, 1/2, 9/16, 19/32, 5/8, 11/16, 3/4, 25/32, 13/16, 7/8, 15/16, 31/32, 1, 1.1/16, 1.1/8, 1.3/16, 1.1/4 AF	Speed Brace 770-L2 Sliding T-Bar 770-L3 Extension Bar 125 mm 770-L5 Extension Bar 250 mm 770-L6 Universal Joint 770-L7	1	5700
0771520342000	771-LAF	Reversible Ratchet with safety locking 770-L1F	Hexagon Sockets 771-LA 3/8, 7/16, 1/2, 9/16, 19/32, 5/8, 11/16, 3/4, 25/32, 13/16, 7/8, 15/16, 31/32, 1, 1.1/16, 1.1/8, 1.3/16, 1.1/4 AF	Speed Brace 770-L2 Sliding T-Bar 770-L3 Extension Bar 125 mm 770-L5 Extension Bar 250 mm 770-L6 Universal Joint 770-L7	1	5700
0770530202000	770-LAU	Reversible Ratchet 770-L1D	Bi-Hexagon Sockets 770-LA 3/8, 7/16, 1/2, 9/16, 19/32, 5/8, 11/16, 3/4, 25/32, 13/16, 7/8, 15/16, 31/32, 1, 1.1/16, 1.1/8, 1.3/16, 1.1/4 AF	Speed Brace 770-L2 Sliding T-Bar 770-L3 Extension Bar 125 mm 770-L5 Extension Bar 250 mm 770-L6 Universal Joint 770-L7	1	5600
0771520302000	771-LAU	Reversible Ratchet 770-L1D	Hexagon Sockets 770-LA 3/8, 7/16, 1/2, 9/16, 19/32, 5/8, 11/16, 3/4, 25/32, 13/16, 7/8, 15/16, 31/32, 1, 1.1/16, 1.1/8, 1.3/16, 1.1/4 AF	Speed Brace 770-L2 Sliding T-Bar 770-L3 Extension Bar 125 mm 770-L5 Extension Bar 250 mm 770-L6 Universal Joint 770-L7	1	5700
0770530202900	770-LAK	Reversible Ratchet 770-L1K	Bi-Hexagon Sockets 770-LA 3/8, 7/16, 1/2, 9/16, 19/32, 5/8, 11/16, 3/4, 25/32, 13/16, 7/8, 15/16, 31/32, 1, 1.1/16, 1.1/8, 1.3/16, 1.1/4 AF	Speed Brace 770-L2 Sliding T-Bar 770-L3 Extension Bar 125 mm 770-L5 Extension Bar 250 mm 770-L6 Universal Joint 770-L7	1	5600
0771520302900	771-LAK	Reversible Ratchet 770-L1K	Hexagon Sockets 771-LA 3/8, 7/16, 1/2, 9/16, 19/32, 5/8, 11/16, 3/4, 25/32, 13/16, 7/8, 15/16, 31/32, 1, 1.1/16, 1.1/8, 1.3/16, 1.1/4 AF	Speed Brace 770-L2 Sliding T-Bar 770-L3 Extension Bar 125 mm 770-L5 Extension Bar 250 mm 770-L6 Universal Joint 770-L7	1	5640

770-OKLAMU/771-OKLAMU

SOCKET SET 1/2"

- 27 pcs.
- in black metal storage case with plastic insert
- square drive according to DIN 3120, ISO 1174
- operation tools according to DIN 3122, ISO 3315

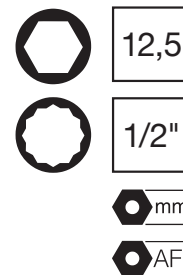

Code	Number	Ratchet	Sockets	Accessories	Pieces	Weight/g
0770530422000	770-OKLAMU	Reversible Ratchet 770-L1D	Bi-Hexagon Sockets 770-LM 10, 11, 13, 14, 17, 19, 22, 24, 27, 30, 32 mm 770-LA 7/16, 1/2, 9/16, 19/32, 5/8, 11/16, 3/4, 25/32, 7/8, 15/16, 1 AF	Sliding T-Bar 770-L3 Extension Bar 125 mm 770-L5 Extension Bar 250 mm 770-L6 Universal Joint 770-L7	1	5000
0771520422000	771-OKLAMU	Reversible Ratchet 770-L1D	Hexagon Sockets 771-LM 10, 11, 13, 14, 17, 19, 22, 24, 27, 30, 32 mm 771-LA 7/16, 1/2, 9/16, 19/32, 5/8, 11/16, 3/4, 25/32, 7/8, 15/16, 1 AF	Sliding T-Bar 770-L3 Extension Bar 125 mm 770-L5 Extension Bar 250 mm 770-L6 Universal Joint 770-L7	1	4800

770-LAMU/771-LAMU

SOCKET SET 1/2"

- 28 pcs.
- in black metal storage case with plastic insert
- square drive according to DIN 3120, ISO 1174
- operation tools according to DIN 3122, ISO 3315

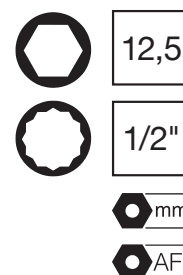

Code	Number	Ratchet	Sockets	Accessories	Pieces	Weight/g
0770530402000	770-LAMU	Reversible Ratchet 770-L1D	Bi-Hexagon Sockets 770-LM 10, 11, 13, 14, 17, 19, 22, 24, 27, 30, 32 mm 770-LA 7/16, 1/2, 9/16, 19/32, 5/8, 11/16, 3/4, 25/32, 7/8, 15/16, 1 AF	Speed Brace 770-L2 Sliding T-Bar 770-L3 Extension Bar 125 mm 770-L5 Extension Bar 250 mm 770-L6 Universal Joint 770-L7	1	5600
0771520402000	771-LAMU	Reversible Ratchet 770-L1D	Hexagon Sockets 771-LM 10, 11, 13, 14, 17, 19, 22, 24, 27, 30, 32 mm 771-LA 7/16, 1/2, 9/16, 19/32, 5/8, 11/16, 3/4, 25/32, 7/8, 15/16, 1 AF	Speed Brace 770-L2 Sliding T-Bar 770-L3 Extension Bar 125 mm 770-L5 Extension Bar 250 mm 770-L6 Universal Joint 770-L7	1	5400

770-LSSMF/771-LSSMF

SOCKET SET 1/2"

- 57 pcs.
- in black metal storage case with OMS-hard foam insert
- square drive according to DIN 3120, ISO 1174
- operation tools according to DIN 3122, ISO 3315



03

Code	Number	Ratchet	Sockets	Accessories	Pieces	Weight/g
0770530702100	770-LSSMF	Reversible Ratchet with safety locking 770-L1F	Bi-Hexagon Sockets 770-LM 10, 11, 12, 13, 14, 15, 16, 17, 18, 19, 20, 21, 22, 23, 24, 25, 26, 27, 28, 30, 32 mm 770-LA 3/8, 7/16, 1/2, 9/16, 19/32, 5/8, 11/16, 3/4, 25/32, 13/16, 7/8, 15/16, 31/32, 1, 1.1/16, 1.1/8, 1.3/16, 1.1/4 AF 770-LW 3/16, 1/4, 5/16, 3/8, 7/16, 1/2 WW Spark Plug Sockets 771-LTZ 16 (5/8"AF), 771-LTZ 20,8 (13/16"AF) Screwdriver Socket 770-L17 (19x3,0 mm)	Speed Brace 770-L2 Sliding T-Bar 770-L3 Extension Bar 75 mm 770-L4 Extension Bar 125 mm 770-L5 Extension Bar 250 mm 770-L6 Universal Joint 770-L7 Offset Handle 770-L8 Flexible Handle 770-L10A Socket Converter, Male 3/8, Female 1/2 770-L13	1	12800
0771530702100	771-LSSMF	Reversible Ratchet with safety locking 770-L1F	Hexagon Sockets 771-LM 10, 11, 12, 13, 14, 15, 16, 17, 18, 19, 20, 21, 22, 23, 24, 25, 26, 27, 28, 30, 32 mm 771-LA 3/8, 7/16, 1/2, 9/16, 19/32, 5/8, 11/16, 3/4, 25/32, 13/16, 7/8, 15/16, 31/32, 1, 1.1/16, 1.1/8, 1.3/16, 1.1/4 AF Bi-Hexagon Sockets 770-LW 3/16, 1/4, 5/16, 3/8, 7/16, 1/2 WW Spark Plug Sockets 771-LTZ 16 (5/8"AF), 771-LTZ 20,8 (13/16"AF) Screwdriver Socket 770-L17 (19x3,0 mm)	Speed Brace 770-L2 Sliding T-Bar 770-L3 Extension Bar 75 mm 770-L4 Extension Bar 125 mm 770-L5 Extension Bar 250 mm 770-L6 Universal Joint 770-L7 Offset Handle 770-L8 Flexible Handle 770-L10A Socket Converter, Male 3/8, Female 1/2 770-L13	1	13600

770-LTI...

SOCKET SET 1/2"

- 18 pcs.
- in black metal storage case with OMS-hard foam insert
- square drive according to DIN 3120, ISO 1174
- operation tools according to DIN 3122, ISO 3315



Code	Number	Ratchet	Sockets	Accessories	Pieces	Weight/g
0770514002000	770-LTIU	Reversible Ratchet 770-L1D	Bi-Hexagon Sockets 770-LT 10, 11, 13, 16, 17, 18, 19, 21, 22, 24, 27, 30, 32 mm, extra deep	Sliding T-Bar 770-L3 Extension Bar 125 mm 770-L5 Extension Bar 250 mm 770-L6 Universal Joint 770-L7	1	5555
0770514002900	770-LTIK	Reversible Ratchet 770-L1K	Bi-Hexagon Sockets 770-LT 10, 11, 13, 16, 17, 18, 19, 21, 22, 24, 27, 30, 32 mm, extra deep	Sliding T-Bar 770-L3 Extension Bar 125 mm 770-L5 Extension Bar 250 mm 770-L6 Universal Joint 770-L7	1	5600

770-LTU/LTK

SOCKET SET 1/2"

- 29 pcs.
- in black metal storage case with plastic insert
- square drive according to DIN 3120, ISO 1174
- operation tools according to DIN 3122, ISO 3315



1/2"



03

Code	Number	Ratchet	Sockets	Accessories	Pieces	Weight/g
0770515002000	770-LTU	Reversible Ratchet 770-L1D	Bi-Hexagon Sockets 770-LM 10, 11, 12, 13, 14, 15, 16, 17, 19, 22, 24, 27, 30, 32 mm 770-LT 10, 11, 12, 13, 14, 15, 17, 19, 21, 22 mm, extra deep	Sliding T-Bar 770-L3 Extension Bar 125 mm 770-L5 Extension Bar 250 mm 770-L6 Universal Joint 770-L7	1	600
0770515002900	770-LTK	Reversible Ratchet 770-L1K	Bi-Hexagon Sockets 770-LM 10, 11, 12, 13, 14, 15, 16, 17, 19, 22, 24, 27, 30, 32 mm 770-LT 10, 11, 12, 13, 14, 15, 17, 19, 21, 22 mm, extra deep	Sliding T-Bar 770-L3 Extension Bar 125 mm 770-L5 Extension Bar 250 mm 770-L6 Universal Joint 770-L7	1	5800

770-IN...

SOCKET SET 1/2"

- INM=9 pcs., INA=7 pcs., INMTIN=9 pcs. titan-coated
- for inside hexagon screws
- in black metal storage case with plastic insert
- chrome-plated, polished
- knurled
- holder made of ELORA-Chrome-Vanadium 31CrV3 / 1.2208
- female square according to DIN 3120-C 12,5, ISO 1174, with ball retaining groove
- blade made of ELORA-Vanadium special steel, gunmetal finished
- according to DIN 7422



1/2"



Code	Number	Contents	Pieces	Weight/g
0770550202500	770-INMTIN	Inside-Hexagon Screwdriver Sockets titan coated: IN 4, 5, 6, 8, 10, 12, 14, 17, 19 mm	1	1600
0770550202000	770-INM	Inside-Hexagon Screwdriver Sockets: IN 4, 5, 6, 8, 10, 12, 14, 17, 19 mm	1	1455
0770550252000	770-INA	Inside-Hexagon Screwdriver Sockets: IN 3/16, 1/4, 5/16, 3/8, 1/2, 9/16, 3/4 AF	1	1300

770-KIN...

SOCKET SET 1/2"

- INM=12 pcs., INA=9 pcs.
- for inside hexagon screws
- in black metal storage case with plastic insert
- chrome-plated, polished
- knurled
- holder made of ELORA-Chrome-Vanadium 31CrV3 / 1.2208
- female square according to DIN 3120-C 12,5, ISO 1174, with ball retaining groove
- blade made of ELORA-Vanadium special steel, gunmetal finished
- according to DIN 7422
- operation tools according to DIN 3122, ISO 3315



12,5

1/2"

mm

AF[®]



03

Code	Number	Ratchet	Sockets	Accessories	Pieces	Weight/g
0770550302000	770-KINMU	Reversible Ratchet 770-L1D	Inside Hexagon Screwdriver Sockets 3210-IN 4, 5, 6, 7, 8, 10, 12, 14, 17, 19 mm	Extension Bar 125 mm 770-L5	1	2500
0770550302900	770-KINMK	Reversible Ratchet 770-L1K	Inside Hexagon Screwdriver Sockets 3210-IN 4, 5, 6, 7, 8, 10, 12, 14, 17, 19 mm	Extension Bar 125 mm 770-L5	1	2500
0770550352000	770-KINAU	Reversible Ratchet 770-L1D	Inside Hexagon Screwdriver Sockets 3210-IN 3/16, 1/4, 5/16, 3/8, 1/2, 9/16, 3/4 AF	Extension Bar 125 mm 770-L5	1	2200
0770550352900	770-KINAK	Reversible Ratchet 770-L1K	Inside Hexagon Screwdriver Sockets 3210-IN 3/16, 1/4, 5/16, 3/8, 1/2, 9/16, 3/4 AF	Extension Bar 125 mm 770-L5	1	2200

770-OKLIM/771-OKLIM

Socket Set 1/2"

- 30 pcs.
- in black metal storage case with plastic insert
- square drive according to DIN 3120, ISO 1174
- operation tools according to DIN 3122, ISO 3315

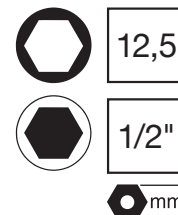

Code	Number	Ratchet	Sockets	Accessories	Pieces	Weight/g
0770550122100	770-OKLIMU	Reversible Ratchet 770-L1D	Bi-Hexagon Sockets 770-LM 10, 11, 12, 13, 14, 15, 16, 17, 18, 19, 21, 22, 23, 24, 26, 27, 30, 32 mm Inside Hexagon Screwdriver Sockets 3210-IN 5, 6, 7, 8, 10, 12, 14 mm	Sliding T-Bar 770-L3 Extension Bar 125 mm 770-L5 Extension Bar 250 mm 770-L6 Universal Joint 770-L7	1	5700
0771530422100	771-OKLIMU	Reversible Ratchet 770-L1D	Hexagon Sockets 771-LM 10, 11, 12, 13, 14, 15, 16, 17, 18, 19, 21, 22, 23, 24, 26, 27, 30, 32 mm Inside Hexagon Screwdriver Sockets 3210-IN 5, 6, 7, 8, 10, 12, 14 mm	Sliding T-Bar 770-L3 Extension Bar 125 mm 770-L5 Extension Bar 250 mm 770-L6 Universal Joint 770-L7	1	5600
0770550122900	770-OKLIMK	Reversible Ratchet 770-L1K	Bi-Hexagon Sockets 770-LM 10, 11, 12, 13, 14, 15, 16, 17, 18, 19, 21, 22, 23, 24, 26, 27, 30, 32 mm Inside Hexagon Screwdriver Sockets 3210-IN 5, 6, 7, 8, 10, 12, 14 mm	Sliding T-Bar 770-L3 Extension Bar 125 mm 770-L5 Extension Bar 250 mm 770-L6 Universal Joint 770-L7	1	5300
0771530422900	771-OKLIMK	Reversible Ratchet 770-L1K	Hexagon Sockets 771-LM 10, 11, 12, 13, 14, 15, 16, 17, 18, 19, 21, 22, 23, 24, 26, 27, 30, 32 mm Inside Hexagon Screwdriver Sockets 3210-IN 5, 6, 7, 8, 10, 12, 14 mm	Sliding T-Bar 770-L3 Extension Bar 125 mm 770-L5 Extension Bar 250 mm 770-L6 Universal Joint 770-L7	1	5300

770-LIM.../771-LIM...

Socket Set 1/2"

- 31 pcs.
- in black metal storage case with plastic insert
- square drive according to DIN 3120, ISO 1174
- operation tools according to DIN 3122, ISO 3315

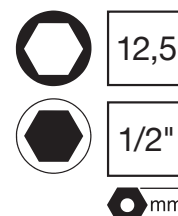

Code	Number	Ratchet	Sockets	Accessories	Pieces	Weight/g
0770550102100	770-LIMU	Reversible Ratchet 770-L1D	Bi-Hexagon Sockets 770-LM 10, 11, 12, 13, 14, 15, 16, 17, 18, 19, 21, 22, 23, 24, 26, 27, 30, 32 mm Inside Hexagon Screwdriver Sockets 3210-IN 5, 6, 7, 8, 10, 12, 14 mm	Speed Brace 770-L2 Sliding T-Bar 770-L3 Extension Bar 125 mm 770-L5 Extension Bar 250 mm 770-L6 Universal Joint 770-L7	1	6000
0771530402100	771-LIMU	Reversible Ratchet 770-L1D	Hexagon Sockets 771-LM 10, 11, 12, 13, 14, 15, 16, 17, 18, 19, 21, 22, 23, 24, 26, 27, 30, 32 mm Inside Hexagon Screwdriver Sockets 3210-IN 5, 6, 7, 8, 10, 12, 14 mm	Speed Brace 770-L2 Sliding T-Bar 770-L3 Extension Bar 125 mm 770-L5 Extension Bar 250 mm 770-L6 Universal Joint 770-L7	1	6700
0770550102900	770-LIMK	Reversible Ratchet 770-L1K	Bi-Hexagon Sockets 770-LM 10, 11, 12, 13, 14, 15, 16, 17, 18, 19, 21, 22, 23, 24, 26, 27, 30, 32 mm Inside Hexagon Screwdriver Sockets 3210-IN 5, 6, 7, 8, 10, 12, 14 mm	Speed Brace 770-L2 Sliding T-Bar 770-L3 Extension Bar 125 mm 770-L5 Extension Bar 250 mm 770-L6 Universal Joint 770-L7	1	5900
0771530402900	771-LIMK	Reversible Ratchet 770-L1K	Hexagon Sockets 771-LM 10, 11, 12, 13, 14, 15, 16, 17, 18, 19, 21, 22, 23, 24, 26, 27, 30, 32 mm Inside Hexagon Screwdriver Sockets 3210-IN 5, 6, 7, 8, 10, 12, 14 mm	Speed Brace 770-L2 Sliding T-Bar 770-L3 Extension Bar 125 mm 770-L5 Extension Bar 250 mm 770-L6 Universal Joint 770-L7	1	5900

770-XZN

Socket Set 1/2"

- 7 pcs.
- for inside multi-point screws
- in black metal storage case with plastic insert
- chrome-plated, polished
- knurled
- holder made of ELORA-Chrome-Vanadium 31CrV3 / 1.2208
- female square according to DIN 3120-C 12,5, ISO 1174, with ball retaining
- blade made of ELORA-Vanadium special steel, gunmetal finished
- blades according to DIN 2325



12,5

1/2"

Code	Number	Sockets	Pieces	Weight/g
0770550272000	770-XZN	Screwdriver Sockets: 3230-XZN M5, M6, M8, M10, M12, M14, M16	1	1200

770-KXZN...

Socket Set 1/2"

- 9 pcs.
- for inside multi-point screws
- in black metal storage case with plastic insert
- square drive according to DIN 3120, ISO 1174
- operation tools according to DIN 3122, ISO 3315



12,5

1/2"

Code	Number	Ratchet	Sockets	Accessories	Pieces	Weight/g
0770550402000	770-KXZNU	Reversible Ratchet 770-L1D	Screwdriver Sockets 3230-XZN M5, M6, M8, M10, M12, M14, M16	Extension Bar 125 mm 770-L5	1	2400
0770550402900	770-KXZNK	Reversible Ratchet 770-L1K	Screwdriver Sockets 3230-XZN M5, M6, M8, M10, M12, M14, M16	Extension Bar 125 mm 770-L5	1	2200

770-OKLX.../771-OKLX...

Socket Set 1/2"

- 30 pcs.
- in black metal storage case with plastic insert
- square drive according to DIN 3120, ISO 1174
- operation tools according to DIN 3122, ISO 3315



12,5



1/2"



mm

Code	Number	Ratchet	Sockets	Accessories	Pieces	Weight/g
0770550522100	770-OKLXZNU	Reversible Ratchet 770-L1D	Bi-Hexagon Sockets 770-LM 10, 11, 12, 13, 14, 15, 16, 17, 18, 19, 21, 22, 23, 24, 26, 27, 30, 32 mm Screwdriver Sockets 3230-XZN M5, M6, M8, M10, M12, M14, M16	Sliding T-Bar 770-L3 Extension Bar 125 mm 770-L5 Extension Bar 250 mm 770-L6 Universal Joint 770-L7	1	5400
0771525522100	771-OKLXZNU	Reversible Ratchet 770-L1D	Hexagon Sockets 771-LM 10, 11, 12, 13, 14, 15, 16, 17, 18, 19, 21, 22, 23, 24, 26, 27, 30, 32 mm Screwdriver Sockets 3230-XZN M5, M6, M8, M10, M12, M14, M16	Sliding T-Bar 770-L3 Extension Bar 125 mm 770-L5 Extension Bar 250 mm 770-L6 Universal Joint 770-L7	1	5400
0770550522900	770-OKLXZNK	Reversible Ratchet 770-L1K	Bi-Hexagon Sockets 770-LM 10, 11, 12, 13, 14, 15, 16, 17, 18, 19, 21, 22, 23, 24, 26, 27, 30, 32 mm Screwdriver Sockets 3230-XZN M5, M6, M8, M10, M12, M14, M16	Sliding T-Bar 770-L3 Extension Bar 125 mm 770-L5 Extension Bar 250 mm 770-L6 Universal Joint 770-L7	1	5300
0771525522900	771-OKLXZNK	Reversible Ratchet 770-L1K	Hexagon Sockets 771-LM 10, 11, 12, 13, 14, 15, 16, 17, 18, 19, 21, 22, 23, 24, 26, 27, 30, 32 mm Screwdriver Sockets 3230-XZN M5, M6, M8, M10, M12, M14, M16	Sliding T-Bar 770-L3 Extension Bar 125 mm 770-L5 Extension Bar 250 mm 770-L6 Universal Joint 770-L7	1	5300

770-LX.../771-LX...

Socket Set 1/2"

- 31 pcs.
- in black metal storage case with plastic insert
- square drive according to DIN 3120, ISO 1174
- operation tools according to DIN 3122, ISO 3315



Code	Number	Ratchet	Sockets	Accessories	Pieces	Weight/g
0770550502100	770-LXZNU	Reversible Ratchet 770-L1D	Bi-Hexagon Sockets 770-LM 10, 11, 12, 13, 14, 15, 16, 17, 18, 19, 21, 22, 23, 24, 26, 27, 30, 32 mm Screwdriver Sockets 3230-XZN M5, M6, M8, M10, M12 M14, M16	Speed Brace 770-L2 Sliding T-Bar 770-L3 Extension Bar 125 mm 770-L5 Extension Bar 250 mm 770-L6 Universal Joint 770-L7	1	6200
0771525502100	771-LXZNU	Reversible Ratchet 770-L1D	Hexagon Sockets 771-LM 10, 11, 12, 13, 14, 15, 16, 17, 18, 19, 21, 22, 23, 24, 26, 27, 30, 32 mm Screwdriver Sockets 3230-XZN M5, M6, M8, M10, M12 M14, M16	Speed Brace 770-L2 Sliding T-Bar 770-L3 Extension Bar 125 mm 770-L5 Extension Bar 250 mm 770-L6 Universal Joint 770-L7	1	6000
0770550502900	770-LXZNK	Reversible Ratchet 770-L1K	Bi-Hexagon Sockets 770-LM 10, 11, 12, 13, 14, 15, 16, 17, 18, 19, 21, 22, 23, 24, 26, 27, 30, 32 mm Screwdriver Sockets 3230-XZN M5, M6, M8, M10, M12 M14, M16	Speed Brace 770-L2 Sliding T-Bar 770-L3 Extension Bar 125 mm 770-L5 Extension Bar 250 mm 770-L6 Universal Joint 770-L7	1	5900
0771525502900	771-LXZNK	Reversible Ratchet 770-L1K	Hexagon Sockets 771-LM 10, 11, 12, 13, 14, 15, 16, 17, 18, 19, 21, 22, 23, 24, 26, 27, 30, 32 mm Screwdriver Sockets 3230-XZN M5, M6, M8, M10, M12 M14, M16	Speed Brace 770-L2 Sliding T-Bar 770-L3 Extension Bar 125 mm 770-L5 Extension Bar 250 mm 770-L6 Universal Joint 770-L7	1	5900

770-TX/770-TTX

Socket Set 1/2"

- 9 pcs.
- suitable for inside TORX® resp. inside-TORX® safety screws
- in black metal storage case with plastic insert
- chrome-plated, polished
- knurled
- holder made of ELORA-Chrome-Vanadium 31CrV3 / 1.2208
- female square according to DIN 3120-C 12,5, ISO 1174, with ball retaining groove
- blade made of ELORA-Vanadium special steel, gunmetal finished
- TORX® = reg. trademark of Acument Intellectual Properties, LLC. USA

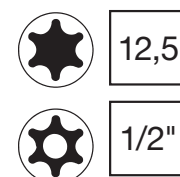

Code	Number	Contents	Pieces	Weight/g
0770551202000	770-TX	TORX®-Screwdriver Sockets: 3245-TX 20, 25, 27, 30, 40, 45, 50, 55, 60	1	1200
0770551252000	770-TTX	TORX®-Screwdriver Sockets: 3245-TTX 20, 25, 27, 30, 40, 45, 50, 55, 60	1	1200

770-TXE

SOCKET SET 1/2"

- 17-pcs.
- suitable for inside- and outside TORX® screws
- in black metal storage case with OMS-hard foam insert
- female square according to DIN 3120-C, 12,5, ISO 1174, with ball retaining groove
- TORX® = reg. trademark of Acument Intellectual Properties, LLC. USA



Code	Number	Contents	Pieces	Weight/g
0770510529000	770-TXE	Sockets 1/2" for outside TORX® screws 770-LTXE 10, 11, 12, 14, 16, 18, 20, 24 mm Screwdriver Sockets 1/2" for inside TORX® safety screws 3245-TTX 20, 25, 27, 30, 40, 45, 50, 55, 60 mm	1	3000

770-KTX.../KTT...

Socket Set 1/2"

- 11 pcs.
- suitable for inside TORX® resp. inside-TORX® safety screws
- in black metal storage case with plastic insert
- square drive according to DIN 3120, ISO 1174
- operation tools according to DIN 3122, ISO 3315
- TORX® = reg. trademark of Acument Intellectual Properties, LLC. USA

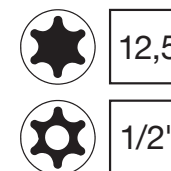

Code	Number	Ratchet	Sockets	Accessories	Pieces	Weight/g
0770551302100	770-KTXU	Reversible Ratchet 770-L1D	TORX®-Screwdriver Sockets 3245-TX 20, 25, 27, 30, 40, 45, 50, 55, 60	Extension Bar 125 mm 770-L5	1	2400
0770551302900	770-KTXK	Reversible Ratchet 770-L1K	TORX®-Screwdriver Sockets 3245-TX 20, 25, 27, 30, 40, 45, 50, 55, 60	Extension Bar 125 mm 770-L5	1	2300
0770551352000	770-KTTXU	Reversible Ratchet 770-L1D	TORX®-Screwdriver Sockets 3245-TTX 20, 25, 27, 30, 40, 45, 50, 55, 60	Extension Bar 125 mm 770-L5	1	2400
0770551352900	770-KTTXK	Reversible Ratchet 770-L1K	TORX®-Screwdriver Sockets 3245-TTX 20, 25, 27, 30, 40, 45, 50, 55, 60	Extension Bar 125 mm 770-L5	1	2300

771-LMIT...

Socket Set 1/2"

- 30 pcs.
- in black metal storage case with plastic insert
- square drive according to DIN 3120, ISO 1174
- operation tools according to DIN 3122, ISO 3315

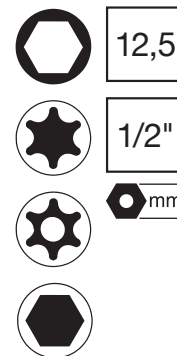

Code	Number	Ratchet	Sockets	Accessories	Pieces	Weight/g
0771510602000	771-LMITXU	Reversible Ratchet 770-L1D	Hexagon Sockets 771-LM 10, 11,12, 13, 14, 15, 17, 19, 22, 24, 27, 30 mm Screwdriver Sockets 3210-IN 5, 6, 7, 8, 10, 12, 14 TORX®-Screwdriver Sockets 3245-TX 30, 40, 45, 50	Extension Bar 125 mm 770-L5 Extension Bar 250 mm 770-L6 Universal Joint 770-L7	1	4600
0771510602900	771-LMITXK	Reversible Ratchet 770-L1K	Hexagon Sockets 771-LM 10, 11,12, 13, 14, 15, 17, 19, 22, 24, 27, 30 mm Screwdriver Sockets 3210-IN 5, 6, 7, 8, 10, 12, 14 TORX®-Screwdriver Sockets 3245-TX 30, 40, 45, 50	Extension Bar 125 mm 770-L5 Extension Bar 250 mm 770-L6 Universal Joint 770-L7	1	4500
0771510702000	771-LMITTXU	Reversible Ratchet 770-L1D	Hexagon Sockets 771-LM 10, 11,12, 13, 14, 15, 17, 19, 22, 24, 27, 30 mm Screwdriver Sockets 3210-IN 5, 6, 7, 8, 10, 12, 14 TORX®-Screwdriver Sockets 3245-TTX 30, 40, 45, 50	Extension Bar 125 mm 770-L5 Extension Bar 250 mm 770-L6 Universal Joint 770-L7	1	4500
0771510702900	771-LMITTXK	Reversible Ratchet 770-L1K	Hexagon Sockets 771-LM 10, 11,12, 13, 14, 15, 17, 19, 22, 24, 27, 30 mm Screwdriver Sockets 3210-IN 5, 6, 7, 8, 10, 12, 14 TORX®-Screwdriver Sockets 3245-TTX 30, 40, 45, 50	Extension Bar 125 mm 770-L5 Extension Bar 250 mm 770-L6 Universal Joint 770-L7	1	4500

770-771-RDS12

COMBINATION SOCKET SET 1/2"

- 49 pcs.
- in black metal storage case with plastic insert
- square drive according to DIN 3120, ISO 1174
- operation tools according to DIN 3122, ISO 3315

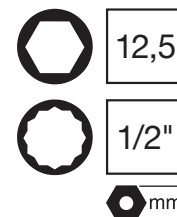
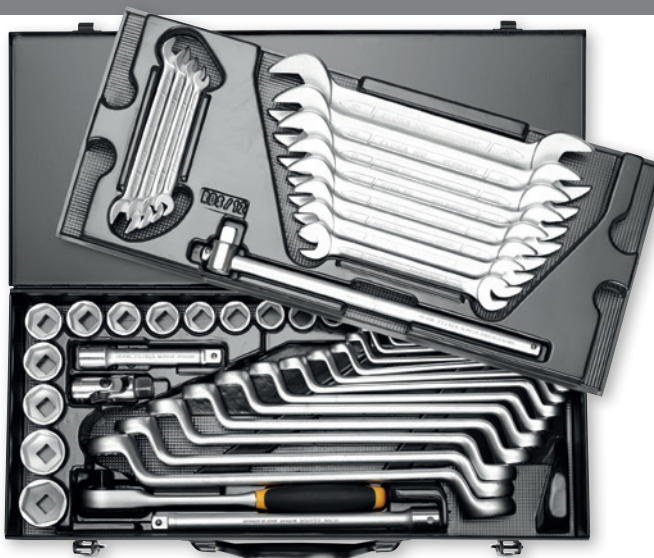

Code	Number	Ratchet	Sockets	Accessories	Pieces	Weight/g
0770560402000	770-RDS12MU	Reversible Ratchet 770-L1D	Bi-Hexagon Sockets 770-LM 10, 11,12, 13, 14, 15, 16, 17, 18, 19, 20, 21, 22, 23, 24, 25, 26, 27, 30, 32 mm Double-Open-Ended Spanner 100- 6x7, 8x9, 10x11, 12x13, 14x15, 16x17, 18x19, 20x22, 21x23, 24x27, 25x28, 30x32 mm Double-Ended Ring Spanner 110- 6x7, 8x9, 10x11, 12x13, 14x15, 16x17, 18x19, 20x22, 21x23, 24x27, 25x28, 30x32 mm	Sliding T-Bar 770-L3 Extension Bar 125 mm 770-L5 Extension Bar 250 mm 770-L6 Universal Joint 770-L7	1	11000
0771550202000	771-RDS12MU	Reversible Ratchet 770-L1D	Hexagon Sockets 771-LM 10, 11,12, 13, 14, 15, 16, 17, 18, 19, 20, 21, 22, 23, 24, 25, 26, 27, 30, 32 mm Double-Open-Ended Spanner 100- 6x7, 8x9, 10x11, 12x13, 14x15, 16x17, 18x19, 20x22, 21x23, 24x27, 25x28, 30x32 mm Double-Ended Ring Spanner 110- 6x7, 8x9, 10x11, 12x13, 14x15, 16x17, 18x19, 20x22, 21x23, 24x27, 25x28, 30x32 mm	Sliding T-Bar 770-L3 Extension Bar 125 mm 770-L5 Extension Bar 250 mm 770-L6 Universal Joint 770-L7	1	11000

You will find the matching OMS-3/4 module on page no. 32



You will find the matching OMS-18 module on page no. 33

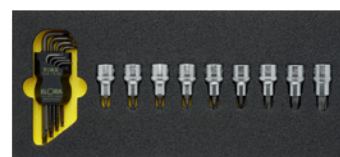

You will find the matching OMS-11/12 module on page no. 45



You will find the matching MS-13 module on page no. 46



You will find the matching MS-14 module on page no. 46



770-S1K

Reversible Ratchet Head 3/4"

- for use with tommy bar ELORA-No. 770-S7
- forged gear with male and female coupler square
- smallest possible swivel angle 11,25°
- matt chrome-plated
- ELORA-Chrome-Vanadium 31CrV3 / 1.2208
- square drive according to DIN 3120-B 20, ISO 1174, with locking pin
- according to DIN 3122, ISO 3315



20
3/4"

Code	Number	l/mm	Pieces	Weight/g
0770020122000	770-S1K	160	1	1365
0770020702000	770-S7	500	3	1335

770-S1U

REVERSIBLE RATCHET 3/4"

- forged gear with male and female coupler square
- smallest possible swivel angle 11,25°
- matt chrome-plated
- ELORA-Chrome-Vanadium 31CrV3 / 1.2208
- square drive according to DIN 3120-B 20, ISO 1174, with locking pin
- according to DIN 3122, ISO 3315



20
3/4"

Code	Number	l/mm	Pieces	Weight/g
0770020102000	770-S1U	500	1	1950
0770021602000	770-S16	Repair Kit	1	530

770-S1ZI

PUSH THROUGH RATCHET 3/4"

- forged gear wheel with push through square coupler
- with suspension hole
- smallest possible swivel angle 10°
- matt chrome-plated
- ELORA-Chrome-Vanadium 31CrV3 / 1.2208
- square drive according to DIN 3120-A 20, ISO 1174, with ball retaining groove



20
3/4"

Code	Number	l/mm	Pieces	Weight/g
0770020112100	770-S1ZI	500	1	1383
0770020132000	770-S1V	42	6	135
0770021702000	770-S17	Repair Kit	1	340

03

770SM-..., 770SA-..., 770SW-...

SOCKET 3/4", BI-HEXAGON

- hot forged
- matt chrome-plated
- knurled
- ELORA-Chrome-Vanadium 31CrV3 / 1.2208
- female square according to DIN 3120-D 20, ISO 1174, with locking pin
- according to DIN 3124, ISO 2725-1



Code	Number	d1 mm	d2 mm	l/mm	Pieces	Weight/g
0770010182000	770-S 18	27,0	35,0	50,0	3	170
0770010192000	770-S 19	28,0	35,0	50,0	3	170
0770010212000	770-S 21	30,6	35,0	50,5	3	180
0770010222000	770-S 22	32,2	35,0	50,5	3	190
0770010232000	770-S 23	33,5	35,0	51,0	3	200
0770010242000	770-S 24	34,5	35,0	52,0	3	190
0770010252000	770-S 25	37,0	35,0	53,0	3	220
0770010262000	770-S 26	38,0	36,0	53,0	3	235
0770010272000	770-S 27	38,6	36,0	55,0	3	230
0770010282000	770-S 28	40,0	36,0	55,5	3	260
0770010292000	770-S 29	41,0	37,0	55,5	3	275
0770010302000	770-S 30	43,0	37,0	57,0	3	290
0770010322000	770-S 32	45,3	38,0	58,5	3	330
0770010332000	770-S 33	46,3	39,0	59,5	3	350
0770010342000	770-S 34	46,8	39,0	59,5	3	360
0770010362000	770-S 36	50,7	40,0	61,0	3	430
0770010372000	770-S 37	51,7	41,0	61,5	3	470
0770010382000	770-S 38 / 1.1/2	53,2	41,0	62,0	3	510
0770010412000	770-S 41	56,0	40,0	64,0	3	605
0770010422000	770-S 42	57,0	40,0	64,0	3	570
0770010462000	770-S 46 / 1.13/16	66,0	42,0	66,0	3	720
0770010472000	770-S 47	63,0	42,0	68,0	1	730
0770010502000	770-S 50	68,0	42,0	68,0	1	840
0770010522000	770-S 52	71,0	45,0	72	1	965
0770010542000	770-S 54	72,0	45,0	74,0	1	955
0770010552000	770-S 55	74,0	45,0	76,0	1	1110
0770010602000	770-S 60	80,0	45,0	78,0	1	1345



Code	Number	d1 mm	d2 mm	l/mm	Pieces	Weight/g
0770210232000	770-SW 1/2	33,5	35,0	51,0	3	190
0770210242000	770-SW 9/16	37,0	35,0	53,0	3	215
0770210262000	770-SW 5/8	40,0	36,0	55,5	3	225
0770210272000	770-SW 11/16	43,0	37,0	57,0	3	290
0770210282000	770-SW 3/4	46,3	39,0	59,5	3	300
0770210302000	770-SW 13/16	48,9	40,0	60,5	1	385
0770210312000	770-SW 7/8	52,3	41,0	61,5	1	445
0770210322000	770-SW 15/16	55,4	42,0	62,5	1	555
0770210342000	770-SW 1	58,3	41,0	63,5	1	600
0770210362000	770-SW 1.1/8	65,0	45,0	73	1	775

Code	Nummer	d1 mm	d2 mm	l/mm	Stück	Gewicht/g
0770110282000	770-SA 3/4	28,0	35,0	50,0	3	170
0770110302000	770-SA 13/16	30,5	35,0	50,0	3	185
0770110312000	770-SA 7/8	32,5	35,0	50,0	3	190
0770110322000	770-SA 15/16	34,5	35,0	52,0	3	190
0770110332000	770-SA 31/32	35,0	35,0	53,0	3	190
0770110342000	770-SA 1	37,0	35,0	53,0	3	215
0770110352000	770-SA 1.1/16	38,6	36,0	55,0	3	235
0770110362000	770-SA 1.1/8	40,7	36,0	55,5	3	245
0770110372000	770-SA 1.3/16	43,0	37,0	57,0	3	255
0770110382000	770-SA 1.1/4	45,3	38,0	58,5	3	335
0770110392000	770-SA 1.5/16	46,3	39,0	59,5	3	350
0770110402000	770-SA 1.3/8	48,9	40,0	60,5	3	395
0770110412000	770-SA 1.7/16	50,7	40,0	62,0	3	435
0770010382000	770-S 38 / 1.1/2	53,2	41,0	62,0	3	510
0770110432000	770-SA 1.9/16	55,4	42,0	62,5	3	540
0770110442000	770-SA 1.5/8	56,0	40,0	64,0	3	585
0770110452000	770-SA 1.11/16	58,0	40,0	65,0	3	615
0770110462000	770-SA 1.3/4	60,0	40,0	66,0	3	600
0770010462000	770-S 46 / 1.13/16	62,0	42,0	66,0	3	720
0770110482000	770-SA 1.7/8	64,0	42,0	68,0	1	720
0770110492000	770-SA 2	68,0	42,0	68,0	1	895
0770110502000	770-SA 2.1/16	70,0	45,0	72,0	1	950
0770110512000	770-SA 2.1/8	72,0	45,0	74,0	1	1045
0770110522000	770-SA 2.3/16	74,0	45,0	76,0	1	1095
0770110532000	770-SA 2.1/4	76,0	45,0	76,0	1	1220
0770110552000	770-SA 2.3/8	80,0	45,0	78,0	1	1380

771SM-...

SOCKET 3/4", HEXAGON

- hot forged
- matt chrome-plated
- knurled
- ELORA-Chrome-Vanadium 31CrV3 / 1.2208
- female square according to DIN 3120-D 20, ISO 1174 with locking pin
- according to DIN 3124, ISO 2725-1

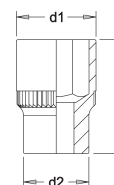

20

3/4"



03

Code	Number	d1 mm	d2 mm	l/mm	Pieces	Weight/g
0771010182000	771-S 18	27,0	35,0	50,0	3	170
0771010192000	771-S 19	28,0	35,0	50,0	3	170
0771010212000	771-S 21	30,6	35,0	50,5	3	180
0771010222000	771-S 22	32,2	35,0	50,5	3	190
0771010232000	771-S 23	33,5	35,0	51,0	3	200
0771010242000	771-S 24	34,5	35,0	52,0	3	190
0771010252000	771-S 25	37,0	35,0	53,0	3	220
0771010262000	771-S 26	38,0	36,0	54,0	3	235
0771010272000	771-S 27	38,6	36,0	55,0	3	230
0771010282000	771-S 28	40,0	36,0	55,5	3	260
0771010292000	771-S 29	41,0	37,0	57	3	275
0771010302000	771-S 30	43,0	37,0	57,0	3	290
0771010322000	771-S 32	45,3	38,0	58,5	3	330
0771010332000	771-S 33	46,3	39,0	59,5	3	350
0771010342000	771-S 34	46,8	39,0	59,5	3	360
0771010362000	771-S 36	50,7	40,0	61,0	3	430
0771010372000	771-S 37	51,7	41,0	61,5	3	470
0771010382000	771-S 38 / 1.1/2	53,2	41,0	62,0	3	510
0771010412000	771-S 41	56,0	40,0	64,0	3	605
0771010422000	771-S 42	57,0	40,0	64,0	3	570
0771010462000	771-S 46 / 1.13/16	62,0	42,0	66,0	3	720
0771010472000	771-S 47	63,0	42,0	68,0	1	730
0771010502000	771-S 50	68,0	42,0	68,0	1	840
0771010542000	771-S 54	72,0	45,0	74,0	1	955
0771010552000	771-S 55	74,0	45,0	76,0	1	1110
0771010602000	771-S 60	80,0	45,0	78,0	1	1345

770-SIN...

SCREWDRIVER SOCKET 3/4"

- for inside hexagon screws
- matt chrome-plated
- knurled
- holder made of ELORA-Chrome-Vanadium 31CrV3 / 1.2208
- female square according to DIN 3120-D 20, ISO 1174, with locking pin
- blade made of ELORA-Vanadium special steel, gunmetal finished
- according to DIN 7422

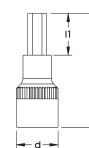

20

3/4"



Code	Number	mm	d mm	l1 mm	l/mm	Pieces	Weight/g
0770050142000	770-SIN 14	M16-18	36,0	25,5	76,5	3	180
0770050172000	770-SIN 17	M20-22	36,0	25,5	76,5	3	190
0770050192000	770-SIN 19	M24-27	36,0	25,5	76,5	3	200
0770050222000	770-SIN 22	M30	36,0	25,5	76,5	3	215

770-S2
FLEXIBLE HANDLE 3/4"

- matt chrome-plated
- with plastic handle
- ELORA-Chrome-Vanadium 31 CrV 3 / 1.2208
- male square according to DIN 3120-B 20, ISO 1174, with locking pin
- according to DIN 3122, ISO 3315



20

3/4"

Code	Number	l/mm	Pieces	Weight/g
0770020202000	770-S2	500	1	1670

770-S3
SLIDING T-BAR 3/4"

- matt chrome-plated
- ELORA-Chrome-Vanadium 31CrV3 / 1.2208
- male square according to DIN 3120-B 20, ISO 1174, with locking pin
- according to DIN 3122, ISO 3315



20

3/4"

Code	Number	l/mm	Pieces	Weight/g
0770020302000	770-S3	480	2	1447

770-S14
SOCKET HANDLE 3/4"

- matt chrome-plated
- with plastic handle
- ELORA-Chrome-Vanadium 31 CrV 3 / 1.2208
- male square according to DIN 3120-B 20, ISO 1174, with locking pin
- according to DIN 3122, ISO 3315



20

3/4"

Code	Number	l/mm	Pieces	Weight/g
0770021402000	770-S14	500	1	1809

770-S4/-S5/-S15
EXTENSION BAR 3/4"

- matt chrome-plated
- ELORA-Chrome-Vanadium 31 CrV 3 / 1.2208
- square drive according to DIN 3120, ISO 1174, with locking pin
- according to DIN 3123, ISO 3316



20

3/4"

Code	Number	l/mm	Pieces	Weight/g
0770021502000	770-S15	100	6	335
0770020402000	770-S4	200	6	590
0770020502000	770-S5	400	3	1085

770-S6
UNIVERSAL JOINT 3/4"

- chrome-plated, polished
- ELORA-Chrome-Vanadium 31CrV3 / 1.2208
- square drive according to DIN 3120, ISO 1174, with locking pin
- according to DIN 3123, ISO 3316



20

3/4"

Code	Number	l/mm	Pieces	Weight/g
0770020602000	770-S6	100	1	465

770-S13

SLIDING HEAD 3/4"

- ▶ for use with tommy bar ELORA-No. 770-S7
- ▶ ELORA-Chrome-Vanadium 31 CrV 3 / 1.2208
- ▶ male square according to DIN 3120-B 20, ISO 1174, with locking pin

20

3/4"



770-S8

FLEXIBLE HEAD 3/4"

- ▶ for use with tommy bar ELORA-No. 770-S7
- ▶ ELORA-Chrome-Vanadium 31 CrV 3 / 1.2208
- ▶ male square according to DIN 3120-B 20, ISO 1174, with locking pin

20

3/4"



Code	Number	l/mm	Pieces	Weight/g
0770021302000	770-S13	65	3	300

Code	Number	l/mm	Pieces	Weight/g
0770020802000	770-S8	110	1	693

770-S7

TOMMY BAR 3/4"

- ▶ with plastic handle
- ▶ for ELORA-No.770-S1K, Reversible Ratchet Head
- ▶ for ELORA-Nr.770-S8, Flexible Head
- ▶ for ELORA-Nr.770-S13, Sliding Head
- ▶ for ELORA-Chrome-Vanadium 31CrV3 / 1.2208



Code	Number	l/mm	Pieces	Weight/g
0770020702000	770-S7	500	3	1335

770-L11/-S.../780-7

SOCKET CONVERTER 3/4"

- ▶ chrome-plated
- ▶ ELORA-Chrome-Vanadium 31CrV3 / 1.2208
- ▶ square drive according to DIN 3120, ISO 1174
- ▶ according to DIN 3123, ISO 3316

20

3/4"



Code	Number	□	□	l/mm	Pieces	Weight/g
0770020902000	770-S9	1/2"	3/4"	57	6	185
0770011002000	770-L11	3/4"	1/2"	45	6	130
0770021102000	770-S11	1	3/4"	55	6	255
0780100072000	780-7	3/4"	1	70	1	425

770-S10 OK.../771-S10 OK...

SOCKET SET 3/4"

- 13 pcs.
- in black metal storage case
- square drive according to DIN 3120, ISO 1174, with locking pin
- operation tools according to DIN 3122, ISO 3315

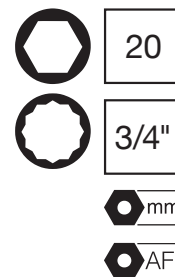

Code	Number	Sockets	Accessories	Pieces	Weight/g
0770580102000	770-S10 OKM	Bi-Hexagon Sockets 770-SM 22, 24, 27, 30, 32, 36, 38, 41, 46, 50 mm	Sliding T-Bar 770-S3 Extension Bar 200 mm 770-S4 Extension Bar 400 mm 770-S5	1	10800
0771540102000	771-S10 OKM	Hexagon Sockets 771-SM 22, 24, 27, 30, 32, 36, 38, 41, 46, 50 mm	Sliding T-Bar 770-S3 Extension Bar 200 mm 770-S4 Extension Bar 400 mm 770-S5	1	11200
0770580112000	770-S10 OKA	Bi-Hexagon Sockets 770-SA 7/8, 15/16, 1, 1.1/16, 1.1/4, 1.7/16, 1.1/2, 1.5/8, 1.13/16, 2 AF	Sliding T-Bar 770-S3 Extension Bar 200 mm 770-S4 Extension Bar 400 mm 770-S5	1	10600

770-S10.../771-S10...

SOCKET SET 3/4"

- 14 pcs.
- in black metal storage case
- square drive according to DIN 3120, ISO 1174, with locking pin
- operation tools according to DIN 3122, ISO 3315

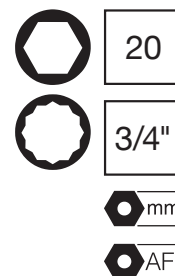

Code	Number	Ratchet	Sockets	Accessories	Pieces	Weight/g
0770580122000	770-S10 MU	Reversible Ratchet 770-S1U	Bi-Hexagon Sockets 770-SM 22, 24, 27, 30, 32, 36, 38, 41, 46, 50 mm	Sliding T-Bar 770-S3 Extension Bar 200 mm 770-S4 Extension Bar 400 mm 770-S5	1	12700
0771540112000	771-S10 MU	Reversible Ratchet 770-S1U	Hexagon Sockets 771-SM 22, 24, 27, 30, 32, 36, 38, 41, 46, 50 mm	Sliding T-Bar 770-S3 Extension Bar 200 mm 770-S4 Extension Bar 400 mm 770-S5	1	12700
0770580132000	770-S10 MZ	Push Through Ratchet 770-S1ZI	Bi-Hexagon Sockets 770-SM 22, 24, 27, 30, 32, 36, 38, 41, 46, 50 mm	Sliding T-Bar 770-S3 Extension Bar 200 mm 770-S4 Extension Bar 400 mm 770-S5	1	12100
0771540122000	771-S10 MZ	Push Through Ratchet 770-S1ZI	Hexagon Sockets 771-SM 22, 24, 27, 30, 32, 36, 38, 41, 46, 50 mm	Sliding T-Bar 770-S3 Extension Bar 200 mm 770-S4 Extension Bar 400 mm 770-S5	1	12100
0770580142000	770-S10 AU	Reversible Ratchet 770-S1U	Bi-Hexagon Sockets 770-SA 7/8, 15/16, 1, 1.1/16, 1.1/4, 1.7/16, 1.1/2, 1.5/8, 1.13/16, 2 AF	Sliding T-Bar 770-S3 Extension Bar 200 mm 770-S4 Extension Bar 400 mm 770-S5	1	12600
0770580152000	770-S10 AZ	Push Through Ratchet 770-S1ZI	Bi-Hexagon Sockets 770-SA 7/8, 15/16, 1, 1.1/16, 1.1/4, 1.7/16, 1.1/2, 1.5/8, 1.13/16, 2 AF	Sliding T-Bar 770-S3 Extension Bar 200 mm 770-S4 Extension Bar 400 mm 770-S5	1	12000

770-S10 K.../771-S10 K...

SOCKET SET 3/4"

- 16 pcs.
- in black metal storage case
- square drive according to DIN 3120, ISO 1174, with locking pin
- operation tools according to DIN 3122, ISO 3315



Code	Number	Ratchet	Sockets	Accessories	Pieces	Weight/g
0770580162000	770-S10 KM	Reversible Ratchet Head 770-S1K	Bi-Hexagon Sockets 770-SM 22, 24, 27, 30, 32, 36, 38, 41, 46, 50 mm	Sliding T-Bar 770-S3 Extension Bar 200 mm 770-S4 Extension Bar 400 mm 770-S5 Tommy Bar 770-S7 Universal Joint 770-S8	1	14000
0771540132000	771-S10 KM	Reversible Ratchet Head 770-S1K	Hexagon Sockets 771-SM 22, 24, 27, 30, 32, 36, 38, 41, 46, 50 mm	Sliding T-Bar 770-S3 Extension Bar 200 mm 770-S4 Extension Bar 400 mm 770-S5 Tommy Bar 770-S7 Universal Joint 770-S8	1	14500
0770580172000	770-S10 KA	Reversible Ratchet Head 770-S1K	Bi-Hexagon Sockets 770-SA 7/8, 15/16, 1, 1.1/16, 1.1/4, 1.7/16, 1.1/2, 1.5/8, 1.13/16, 2 AF	Sliding T-Bar 770-S3 Extension Bar 200 mm 770-S4 Extension Bar 400 mm 770-S5 Tommy Bar 770-S7 Universal Joint 770-S8	1	13900

770-S12.../771-S12...

SOCKET SET 3/4"

- 16 pcs.
- in black metal storage case
- square drive according to DIN 3120, ISO 1174, with locking pin
- operation tools according to DIN 3122, ISO 3315



Code	Number	Ratchet	Sockets	Accessories	Pieces	Weight/g
0770580182000	770-S12 MU	Reversible Ratchet 770-S1U	Bi-Hexagon Sockets 770-SM 22, 24, 27, 30, 32, 36, 38, 41, 46, 50, 55, 60 mm	Sliding T-Bar 770-S3 Extension Bar 200 mm 770-S4 Extension Bar 400 mm 770-S5	1	13900
0771540142000	771-S12 MU	Reversible Ratchet 770-S1U	Hexagon Sockets 771-SM 22, 24, 27, 30, 32, 36, 38, 41, 46, 50, 55, 60 mm	Sliding T-Bar 770-S3 Extension Bar 200 mm 770-S4 Extension Bar 400 mm 770-S5	1	15900
0770580192000	770-S12 AU	Reversible Ratchet 770-S1U	Bi-Hexagon Sockets 770-SA 3/4, 13/16, 7/8, 15/16, 1, 1.1/16, 1.1/4, 1.7/16, 1.1/2, 1.5/8, 1.13/16, 2 AF	Sliding T-Bar 770-S3 Extension Bar 200 mm 770-S4 Extension Bar 400 mm 770-S5	1	13900

770-S15.../771-S15...

SOCKET SET 3/4"

- MU=21 pcs., AU=20 pcs.
- in black metal storage case
- square drive according to DIN 3120, ISO 1174, with locking pin
- operation tools according to DIN 3122, ISO 3315



20



3/4"



6mm



AF"



03

Code	Number	Ratchet	Sockets	Accessories	Pieces	Weight/g
0770580202000	770-S15 MU	Reversible Ratchet 770-S1U	Bi-Hexagon Sockets 770-SM 21, 22, 24, 27, 28, 30, 32, 34, 36, 38, 41, 42, 46, 47, 50 mm	Flexible Handle 770-S2 Sliding T-Bar 770-S3 Extension Bar 200 mm 770-S4 Extension Bar 400 mm 770-S5 Universal Joint 770-S6	1	17800
0771540152000	771-S15 MU	Reversible Ratchet 770-S1U	Hexagon Sockets 771-SM 21, 22, 24, 27, 28, 30, 32, 34, 36, 38, 41, 42, 46, 47, 50 mm	Flexible Handle 770-S2 Sliding T-Bar 770-S3 Extension Bar 200 mm 770-S4 Extension Bar 400 mm 770-S5 Universal Joint 770-S6	1	18000
0770580212000	770-S15 MZ	Push Through Ratchet 770-S1ZI	Bi-Hexagon Sockets 770-SM 21, 22, 24, 27, 28, 30, 32, 34, 36, 38, 41, 42, 46, 47, 50 mm	Flexible Handle 770-S2 Sliding T-Bar 770-S3 Extension Bar 200 mm 770-S4 Extension Bar 400 mm 770-S5 Universal Joint 770-S6	1	17200
0771540162000	771-S15 MZ	Push Through Ratchet 770-S1ZI	Hexagon Sockets 771-SM 21, 22, 24, 27, 28, 30, 32, 34, 36, 38, 41, 42, 46, 47, 50 mm	Flexible Handle 770-S2 Sliding T-Bar 770-S3 Extension Bar 200 mm 770-S4 Extension Bar 400 mm 770-S5 Universal Joint 770-S6	1	17800
0770580222000	770-S15 AU	Reversible Ratchet 770-S1U	Bi-Hexagon Sockets 770-SA 7/8, 15/16, 1, 1.1/16, 1.1/8, 1.1/4, 1.5/16, 1.3/8, 1.7/16, 1.1/2, 1.5/8, 1.11/16, 1.13/16, 1.7/8, 2 AF	Flexible Handle 770-S2 Sliding T-Bar 770-S3 Extension Bar 200 mm 770-S4 Extension Bar 400 mm 770-S5 Universal Joint 770-S6	1	17800
0770580232000	770-S15 AZ	Push Through Ratchet 770-S1ZI	Bi-Hexagon Sockets 770-SA 7/8, 15/16, 1, 1.1/16, 1.1/8, 1.1/4, 1.5/16, 1.3/8, 1.7/16, 1.1/2, 1.5/8, 1.11/16, 1.13/16, 1.7/8, 2 AF	Flexible Handle 770-S2 Sliding T-Bar 770-S3 Extension Bar 200 mm 770-S4 Extension Bar 400 mm 770-S5 Universal Joint 770-S6	1	17200

770-S22...

SOCKET SET 3/4 3/4"

- 32 pcs.
- in black metal storage case
- square drive according to DIN 3120, ISO 1174, with locking pin
- operation tools according to DIN 3122, ISO 3315



20

3/4"



03

Code	Number	Ratchet	Sockets	Accessories	Pieces	Weight/g
0770580302000	770-S22 MAU	Reversible Ratchet 770-S1U	Bi-Hexagon Sockets 770-SM 19, 22, 24, 27, 30, 32, 36, 38, 41, 46, 50 mm 770-SA 3/4, 7/8, 15/16, 1, 1.1/16, 1.1/4, 1.7/16, 1.1/2, 1.5/8, 1.13/16, 2 AF	Flexible Handle 770-S2 Sliding T-Bar 770-S3 Extension Bar 100 mm 770-S15 Extension Bar 200 mm 770-S4 Extension Bar 400 mm 770-S5 Universal Joint 770-S6 Socket Converter, Male 1/2, Female 3/4 770-S9 Socket Converter, Male 1, Female 3/4 770-S11	1	24800
0770580312000	770-S22 MAZ	Push Through Ratchet 770-S1ZI	Bi-Hexagon Sockets 770-SM 19, 22, 24, 27, 30, 32, 36, 38, 41, 46, 50 mm 770-SA 3/4, 7/8, 15/16, 1, 1.1/16, 1.1/4, 1.7/16, 1.1/2, 1.5/8, 1.13/16, 2 AF	Flexible Handle 770-S2 Sliding T-Bar 770-S3 Extension Bar 100 mm 770-S15 Extension Bar 200 mm 770-S4 Extension Bar 400 mm 770-S5 Universal Joint 770-S6 Socket Converter, Male 1/2, Female 3/4 770-S9 Socket Converter, Male 1, Female 3/4 770-S11	1	21000

You will find the matching OMS-35/25 module on page no. 32



770-S24/26.../771-S24/26...

SOCKET SET 3/4"

- MU and MZ = 34 pcs.,
AU and AZ = 35 pcs.
- in black metal storage case
- square drive according to DIN 3120, ISO 1174,
with locking pin
- operation tools according to DIN 3122, ISO 3315

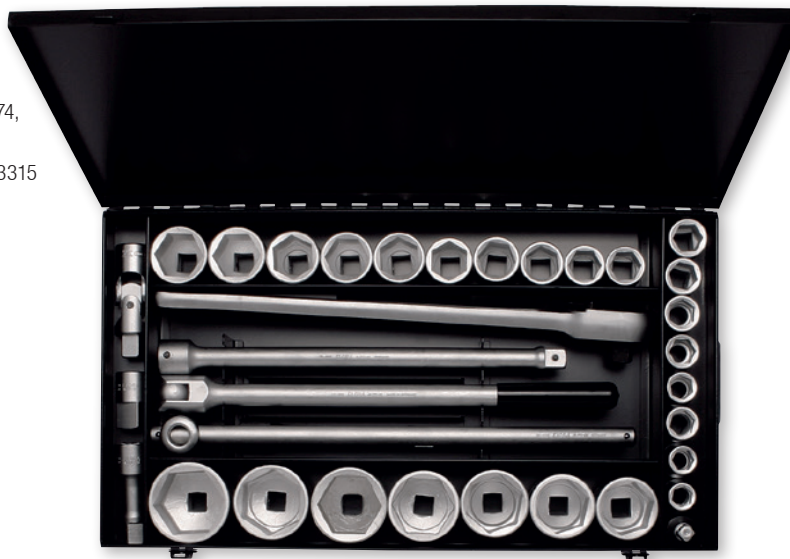

03

Code	Number	Ratchet	Sockets	Accessories	Pieces	Weight/g
0770580422000	770-S24/1 MU	Reversible Ratchet 770-S1U	Bi-Hexagon Sockets 770-SM 18, 19, 21, 22, 23, 24, 25, 26, 27, 28, 30, 32, 34, 36, 37, 38, 41, 42, 46, 47, 50, 54, 55, 60 mm	Flexible Handle 770-S2 Sliding T-Bar 770-S3 Extension Bar 100 mm 770-S15 Extension Bar 200 mm 770-S4 Extension Bar 400 mm 770-S5 Universal Joint 770-S6 Socket Converter, Male 1/2, Female 3/4 770-S9 Socket Converter, Male 1, Female 3/4 770-S11	1	25000
0771540282000	771-S24/1 MU	Reversible Ratchet 770-S1U	Hexagon Sockets 771-SM 18, 19, 21, 22, 23, 24, 25, 26, 27, 28, 30, 32, 34, 36, 37, 38, 41, 42, 46, 47, 50, 54, 55, 60 mm	Flexible Handle 770-S2 Sliding T-Bar 770-S3 Extension Bar 100 mm 770-S15 Extension Bar 200 mm 770-S4 Extension Bar 400 mm 770-S5 Universal Joint 770-S6 Socket Converter, Male 1/2, Female 3/4 770-S9 Socket Converter, Male 1, Female 3/4 770-S11	1	25000
0770580432000	770-S24/1 MZ	Push Through Ratchet 770-S1ZI	Bi-Hexagon Sockets 770-SM 18, 19, 21, 22, 23, 24, 25, 26, 27, 28, 30, 32, 34, 36, 37, 38, 41, 42, 46, 47, 50, 54, 55, 60 mm	Flexible Handle 770-S2 Sliding T-Bar 770-S3 Extension Bar 100 mm 770-S15 Extension Bar 200 mm 770-S4 Extension Bar 400 mm 770-S5 Universal Joint 770-S6 Socket Converter, Male 1/2, Female 3/4 770-S9 Socket Converter, Male 1, Female 3/4 770-S11	1	24500
0771540292000	771-S24/1 MZ	Push Through Ratchet 770-S1ZI	Hexagon Sockets 771-SM 18, 19, 21, 22, 23, 24, 25, 26, 27, 28, 30, 32, 34, 36, 37, 38, 41, 42, 46, 47, 50, 54, 55, 60 mm	Flexible Handle 770-S2 Sliding T-Bar 770-S3 Extension Bar 100 mm 770-S15 Extension Bar 200 mm 770-S4 Extension Bar 400 mm 770-S5 Universal Joint 770-S6 Socket Converter, Male 1/2, Female 3/4 770-S9 Socket Converter, Male 1, Female 3/4 770-S11	1	25200
0770580502000	770-S26 AU	Reversible Ratchet 770-S1U	Bi-Hexagon Sockets 770-SA 3/4, 13/16, 7/8, 15/16, 31/32, 1, 1.1/16, 1.1/8, 1.3/16, 1.1/4, 1.5/16, 1.3/8, 1.7/16, 1.1/2, 1.9/16, 1.5/8, 1.11/16, 1.3/4, 1.13/16, 1.7/8, 2, 2.1/16, 2.1/8, 2.3/16, 2.1/4, 2.3/8 AF	Flexible Handle 770-S2 Sliding T-Bar 770-S3 Extension Bar 100 mm 770-S15 Extension Bar 200 mm 770-S4 Extension Bar 400 mm 770-S5 Universal Joint 770-S6 Socket Converter, Male 1/2, Female 3/4 770-S9 Socket Converter, Male 1, Female 3/4 770-S11	1	27000
0770580512000	770-S26 AZ	Push Through Ratchet 770-S1ZI	Bi-Hexagon Sockets 770-SA 3/4, 13/16, 7/8, 15/16, 31/32, 1, 1.1/16, 1.1/8, 1.3/16, 1.1/4, 1.5/16, 1.3/8, 1.7/16, 1.1/2, 1.9/16, 1.5/8, 1.11/16, 1.3/4, 1.13/16, 1.7/8, 2, 2.1/16, 2.1/8, 2.3/16, 2.1/4, 2.3/8 AF	Flexible Handle 770-S2 Sliding T-Bar 770-S3 Extension Bar 100 mm 770-S15 Extension Bar 200 mm 770-S4 Extension Bar 400 mm 770-S5 Universal Joint 770-S6 Socket Converter, Male 1/2, Female 3/4 770-S9 Socket Converter, Male 1, Female 3/4 770-S11	1	26500

780-1

REVERSIBLE RATCHET 1", WITH TOMMY BAR

- forged gear wheel with 1" male- and 3/4" female square
- smallest possible swivel angle 11,25°
- matt chrome-plated
- ELORA-Chrome-Vanadium 31CrV3 / 1.2208
- male square drive according to DIN 3120-B 25, ISO 1174, with locking pin
- according to DIN 3122, ISO 3315



25

1"

Code	Number	l/mm	Pieces	Weight/g
0780000012000	780-1	660	1	3980
0780000012100	780-E1	Repair Kit	1	560

780M-...

SOCKET 1", BI-HEXAGON

- hot forged
- matt chrome-plated
- Chrome-Vanadium 31 CrV 3 / 1.2208
- female square according to DIN 3120-D 25, ISO 1174, with locking pin
- according to DIN 3124, ISO 2725-1



25

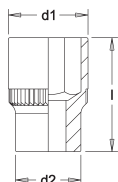

1"



Code	Number	d1 mm	d2 mm	l/mm	Pieces	Weight/g
0780000361000	780-36	52,0	45,0	65,0	1	508
0780000381000	780-38 / 1.1/2	54,0	45,0	65,0	1	514
0780000411000	780-41 / 1.5/8	57,0	45,0	70,0	1	586
0780000461000	780-46 / 1.13/16	65,0	50,0	75,0	1	860
0780000501000	780-50	70,0	50,0	75,0	1	942
0780000551000	780-55	76,0	55,0	80,0	1	1178
0780000601000	780-60	82,0	55,0	84,0	1	1387
0780000651000	780-65	88,0	55,0	87,5	1	1525
0780000701000	780-70	94,0	60,0	93,0	1	1915
0780000751000	780-75	100,0	60,0	97,0	1	2100
0780000801000	780-80	105,0	60,0	103,0	1	2390

780A-...

SOCKET 1", BI-HEXAGON

- hot forged
- matt chrome-plated
- Chrome-Vanadium 31 CrV 3 / 1.2208
- female square according to DIN 3120-D 25, ISO 1174, with locking pin
- according to DIN 3124, ISO 2725-1



25

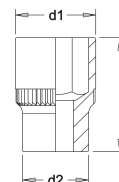

1"



Code	Number	d1 mm	d2 mm	l/mm	Pieces	Weight/g
0780100211000	780A-1.7/16	52,0	45,0	65,0	1	504
0780000381000	780-38 / 1.1/2	54,0	45,0	65,0	1	514
0780000411000	780-41 / 1.5/8	57,0	45,0	70,0	1	586
0780000461000	780-46 / 1.13/16	65,0	50,0	75,0	1	860
0780100491000	780A-2	70,0	50,0	75,0	1	931
0780100521000	780A-2.3/16	76,0	55,0	80,0	1	1190
0780100551000	780A-2.3/8	82,0	55,0	84,0	1	1351
0780100581000	780A-2.9/16	88,0	55,0	90	1	1549
0780100591000	780A-2.5/8	90,0	55,0	90,0	1	1557
0780100601000	780A-2.3/4	94,0	60,0	93	1	1909
0780100631000	780A-3	102,0	60,0	103,0	1	2200
0780100641000	780A-3.1/8	105,0	60,0	103,0	1	2280

780-IN...

SCREWDRIVER SOCKET 1"

- ▶ for inside hexagon screws
- ▶ matt chrome-plated
- ▶ ELORA-Chrome-Vanadium 31CrV3 / 1.2208
- ▶ female square according to DIN 3120-D 25, ISO 1174
- ▶ according to DIN 7422



25

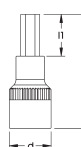

1"

Code	Number	mm	d mm	l1 mm	l/mm	Pieces	Weight/g
0780050171000	780-IN 17	M20-22	48,0	25,0	90	1	544
0780050191000	780-IN 19	M24-27	48,0	25,0	90	1	569
0780050221000	780-IN 22	M30	48,0	25,0	90	1	611
0780050241000	780-IN 24	M33	48,0	25,0	90	1	635

03

780-2

SLIDING T-BAR 1"

- ▶ matt chrome-plated
- ▶ ELORA-Chrome-Vanadium 31CrV3 / 1.2208
- ▶ male square according to DIN 3120-B 25, ISO 1174, with locking pin
- ▶ according to DIN 3122, ISO 3315



25

1"

Code	Number	l/mm	Pieces	Weight/g
0780000022000	780-2	640	1	3500

780-3/4

EXTENSION BAR 1"

- ▶ matt chrome-plated
- ▶ ELORA-Chrome-Vanadium 31 CrV 3 / 1.2208
- ▶ square drive according to DIN 3120, ISO 1174, with locking pin
- ▶ according to DIN 3123, ISO 3316



25

1"

Code	Number	l/mm	Pieces	Weight/g
0780000032000	780-3	200	1	1183
0780000042000	780-4	400	1	1990

780-7/770-S11

SOCKET CONVERTER 1"

- ▶ matt chrome-plated
- ▶ ELORA-Chrome-Vanadium 31CrV3 / 1.2208
- ▶ square drive according to DIN 3120, ISO 1174, with locking pin
- ▶ according to DIN 3123, ISO 3316



25

1"

Code	Number	l/mm			Pieces	Weight/g
0780100072000	780-7	70	3/4"	1	1	425
0770021102000	770-S11	55	1	3/4"	6	255

780-10...

SOCKET SET

- 14 pcs.
- in black metal storage case
- square drive according to DIN 3120, ISO 1174, with locking pin
- operation tools according to DIN 3122, ISO 3315



Code	Number	Ratchet	Sockets	Accessories	Pieces	Weight/g
0780501001000	780-10M	Reversible Ratchet 780-1	Bi-Hexagon Sockets 780- 36, 41, 46, 50, 55, 60, 65, 70, 75, 80 mm	Sliding T-Bar 780-2 Extension Bar 200 mm 780-3 Extension Bar 400 mm 780-4	1	33800
0780601001000	780-10A	Reversible Ratchet 780-1	Bi-Hexagon Sockets 780A- 1.7/16, 1.5/8, 1.13/16, 2, 2.3/16, 2.3/8, 2.9/16, 2.3/4, 3, 3.1/8 AF	Sliding T-Bar 780-2 Extension Bar 200 mm 780-3 Extension Bar 400 mm 780-4	1	33800

OTHER TYPES

765-...

RATCHET OPERATED PODGER SPANNER

- for scaffolding and constructional steel work
- reversible ratchets with two different sizes, with centering tips
- with lock hole \varnothing 5,2 mm
- smallest possible swivel angle 11,25°
- chrome-plated
- Chrome-Vanadium 31CrV3 / 1.2208



Code	Number	l/mm	Pieces	Weight/g
0765017191000	765-17x19	310	1	450
0765017211000	765-17x21	310	1	450
0765019221000	765-19x22	310	1	450
0765024301000	765-24x30	450	1	1280
0765027321000	765-27x32	450	1	1300
0765036411000	765-36x41	450	1	1320





ELORA



IMPACT TOOLS

Impact-Tools 1/4"	_____	Page 198
Impact-Tools 3/8"	_____	Page 201
Impact-Tools 1/2"	_____	Page 204
Impact-Tools 3/4"	_____	Page 211
Impact-Tools 1"	_____	Page 216
Impact-Tools 1.1/2"	_____	Page 220
Impact-Tools 2.1/2"	_____	Page 224
Impact-Screwdriver Insert bits and bit couplers	_____	Page 226



Four steps to success at ELORA: learning, skills, knowledge and guidance. A path already taken by four generations of employees and customers.

788-..., 788A-...

IMPACT SOCKET 1/4", HEXAGON

- for power tools
- special steel, phosphated
- female square drive according to DIN 3121-G 6,3, ISO 1174
- according to DIN 3129, ISO 2725-2

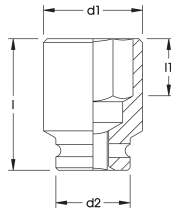

6,3

1/4"



Code	Number	l/mm	l1 mm	d1 mm	d2 mm	Locking Pin	Locking Ring	Pieces	Weight/g
0788000405100	788-4	23	4	7,5	13	7883-11	7884-11	6	14
0788000455100	788-4,5	23	4	8	13	7883-11	7884-11	6	14
0788000505100	788-5	23	5	8,5	13	7883-11	7884-11	6	14
0788000555100	788-5,5	23	5	9	13	7883-11	7884-11	6	14
0788000605100	788-6	23	6	10	13	7883-11	7884-11	6	14
0788000705100	788-7	23	6	11	13	7883-11	7884-11	6	15
0788000805100	788-8	23	7	12	13	7883-11	7884-11	6	15
0788000905100	788-9	23	7	13	13	7883-11	7884-11	6	15
0788001005100	788-10	23	7	14,5	13	7883-11	7884-11	6	17
0788001105100	788-11	23	8	16	13	7883-11	7884-11	6	17
0788001205100	788-12	23	9	17	13	7883-11	7884-11	6	18
0788001305100	788-13	23	9	18	13	7883-11	7884-11	6	18
0788001405100	788-14	23	9	20	13	7883-11	7884-11	6	24
0788001705100	788-17	26	10	24	13	7883-11	7884-11	6	35



Code	Number	l/mm	l1 mm	d1 mm	d2 mm	Locking Pin	Locking Ring	Pieces	Weight/g
0788100135100	788A-1/4	23	5	10,5	13	7883-11	7884-11	6	15
0788100175100	788A-5/16	23	5	12	13	7883-11	7884-11	6	15
0788100185100	788A-11/32	23	5	13	13	7883-11	7884-11	6	15

796-E...

IMPACT SOCKET 1/4"

- for outside TORX® screws
- for power tools
- special steel, phosphated
- female square according to DIN 3121-G6, 3, ISO 1174
- TORX® = reg. trademark of Acument Intellectual Properties, LLC. USA

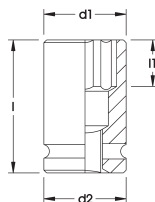

6,3

1/4"

Code	Number	★ mm	l/mm	l1 mm	d1 mm	d2 mm	Locking Pin	Locking Ring	Pieces	Weight/g
0796000045000	796-E4	3,86	23	3,2	7,4	13	7883-11	7884-11	6	15
0796000055000	796-E5	4,73	23	3,2	8,3	13	7883-11	7884-11	6	15
0796000065000	796-E6	5,74	23	4	9,3	13	7883-11	7884-11	6	15
0796000075000	796-E7	6,16	23	4,8	9,8	13	7883-11	7884-11	6	15
0796000085000	796-E8	7,52	23	5,6	11,1	13	7883-11	7884-11	6	15
0796000105000	796-E10	9,42	23	6,4	13	13	7883-11	7884-11	6	16

7900-...

IMPACT EXTENSION BAR 1/4"

- ▶ for power tools
- ▶ special steel, phosphated
- ▶ square according to DIN 3121, form F and G, ISO 1174

6,3

1/4"



Code	Number	l/mm	Locking Pin	Locking Ring	Pieces	Weight/g
7900000505100	7900-50	50	7883-11	7884-11	6	28
7900001005100	7900-100	100	7883-11	7884-11	6	48

795-1/4

IMPACT UNIVERSAL JOINT 1/4"

- ▶ for power tools
- ▶ special steel, phosphated
- ▶ square according to DIN 3121, form F and G, ISO 1174

6,3

1/4"



Code	Number	l/mm	Locking Pin	Locking Ring	Pieces	Weight/g
0795100135100	795-1/4	40	7883-13	7884-14	3	25

7907-...

IMPACT ADAPTOR

- ▶ for power tools
- ▶ special steel, phosphated
- ▶ square according to DIN 3121, form F and G, ISO 1174

6,3

1/4"



Code	Number	□	■	l/mm	Locking Pin	Locking Ring	Pieces	Weight/g
7907100175100	7907-5/16	1/4"	5/16"	25	7883-11	7884-11	3	18
7907100195100	7907-3/8	1/4"	3/8"	25	7883-11	7884-11	3	20

You will find the matching socket rails on page no. 131



4140-...

ADAPTOR 1/4"

- for power tools
- **ELORA-Nr. 4140-50:** male square drive according to DIN 3121 E 6,3, ISO 1174 with locking pin, according to DIN 7428, ISO 3317
- **ELORA-Nr. 4140-100:** male square drive according to DIN 3120 A 6,3, ISO 1174 with ball locking device

6,3

1/4"



Code	Number	l/mm			Pieces	Weight/g
4140000505200	4140-50	50	1/4"	1/4"	6	15,6
4140001005200	4140-100	100	1/4"	1/4"	6	38,0

7883-.../7884-...

IMPACT LOCKING PIN AND RING FOR IMPACT SOCKET 1/4"

- for locking impact sockets and operating tools
- locking pin made of alloyed special steel
- locking ring made of rubber elastic and oil resistant material



Code	Number	l/mm	mm Ø	Pieces	Weight/g
7883000115100	7883-11	11	1,5	12	0,2
7883000135100	7883-13	13	1,5	12	0,2
7884000115100	7884-11	-	11	12	0,2
7884000145100	7884-14	-	14	12	0,2

789-.../789A-...

IMPACT SOCKET 3/8", HEXAGON

- for power tools
- special steel, phosphated
- female square drive according to DIN 3121-G 10, ISO 1174
- according to DIN 3129, ISO 2725-2

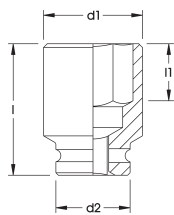

10

3/8"



Code	Number	l/mm	l1 mm	d1 mm	d2 mm	Locking Pin	Locking Ring	Pieces	Weight/g
0789000605100	789-6	32	5	11,3	19	7893-15	7894-15	6	40
0789000705100	789-7	32	5	12,5	19	7893-15	7894-15	6	40
0789000805100	789-8	32	6	13,7	19	7893-15	7894-15	6	40
0789000905100	789-9	32	6	15,0	19	7893-15	7894-15	6	40
0789001005100	789-10	32	7	16,3	19	7893-15	7894-15	6	41
0789001105100	789-11	32	7	17,5	19	7893-15	7894-15	6	41
0789001205100	789-12	32	8	19,0	19	7893-15	7894-15	6	58
0789001305100	789-13	32	8	20,0	22	7893-18	7894-18	6	40
0789001405100	789-14	32	9	21,3	22	7893-18	7894-18	6	58
0789001505100	789-15	32	9	22,5	22	7893-18	7894-18	6	58
0789001605100	789-16	32	10	23,8	22	7893-18	7894-18	6	58
0789001705100	789-17	32	10	25,0	22	7893-18	7894-18	6	66
0789001805100	789-18	32	11	26,3	22	7893-18	7894-18	6	66
0789001905100	789-19	32	12	27,5	22	7893-18	7894-18	6	66
0789002005100	789-20	34	12	29,0	22	7893-18	7894-18	6	75
0789002105100	789-21	34	13	30,0	22	7893-18	7894-18	6	75
0789002205100	789-22	34	14	31,3	22	7893-18	7894-18	6	75
0789002305100	789-23	34	15	32,5	22	7893-18	7894-18	6	75
0789002405100	789-24	36	16	33,8	22	7893-18	7894-18	6	75



Code	Number	l/mm	l1 mm	d1 mm	d2 mm	Locking Pin	Locking Ring	Pieces	Weight/g
0789100175100	789A-5/16	29,5	5	12,5	19	7893-15	7894-15	6	40
0789100215100	789A-7/16	29,5	7	17,0	19	7893-15	7894-15	6	41
0789100235100	789A-1/2	29,5	7	20,0	19	7893-15	7894-15	6	55
0789100245100	789A-9/16	31,5	8	22,0	22	7893-18	7894-18	6	56
0789100315100	789A-7/8	34	12	31,0	25	7893-18	7894-18	6	75

789MG-...

IMPACT SOCKET 3/8", WITH MAGNETIC INSERT, HEXAGON

- for power tools
- special steel, gunmetal-finish
- female square drive according to DIN 3121-G 10, ISO1174
- according to DIN 3129, ISO 2725-2

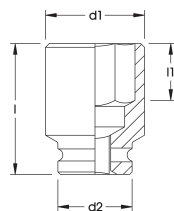

10

3/8"



Code	Number	l/mm	l1 mm	d1 mm	d2 mm	Locking Pin	Locking Ring	Pieces	Weight/g
0789016085100	789MG-8	30	4	14,5	19	7893-15	7894-15	6	42
0789016095100	789MG-9	30	4	15	19	7893-15	7894-15	6	42
0789016105100	789MG-10	30	5	16	19	7893-15	7894-15	6	42
0789016135100	789MG-13	30	6	19	22	7893-18	7894-18	6	42
0789016155100	789MG-15	30	7	22	22	7893-18	7894-18	6	42
0789016165100	789MG-16	30	8	24	22	7893-18	7894-18	6	62
0789016175100	789MG-17	30	9	25	22	7893-18	7894-18	6	62
0789016185100	789MG-18	30	9	26	22	7893-18	7894-18	6	62
0789016195100	789MG-19	30	9,5	27,5	22	7893-18	7894-18	6	62

04

797-E...

IMPACT SOCKET 3/8"

- for outside TORX® screws
- for power tools
- special steel, phosphated
- female square drive according to DIN 3121-G 10, ISO 1174
- TORX® = reg. trademark of Acument Intellectual Properties, LLC. USA

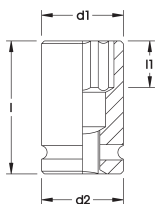

10

3/8"

Code	Number	mm	l/mm	l1 mm	d1 mm	d2 mm	Locking Pin	Locking Ring	Pieces	Weight/g
0797000045000	797-E4	3,86	32	5	9	19	7893-15	7894-15	6	43
0797000055000	797-E5	4,73	32	5	9	19	7893-15	7894-15	6	43
0797000065000	797-E6	5,74	32	7	10	19	7893-15	7894-15	6	42
0797000075000	797-E7	6,16	32	7	10	19	7893-15	7894-15	6	42
0797000085000	797-E8	7,52	32	8	10,5	19	7893-15	7894-15	6	42
0797000105000	797-E10	9,42	32	9	12,5	19	7893-15	7894-15	6	42
0797000125000	797-E12	11,17	32	10	15	19	7893-15	7894-15	6	42
0797000145000	797-E14	12,9	32	12	17,5	19	7893-15	7894-15	6	44
0797000165000	797-E16	14,76	32	12	19	19	7893-15	7894-15	6	42

789IN-...

IMPACT SCREWDRIVER SOCKET 3/8"

- for inside hexagon screws
- for power tools
- with exchangeable blades
- special steel, phosphated
- female square drive according to DIN 3121-G 10, ISO 1174

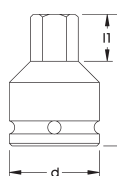

10

3/8"

Code	Number	l/mm	l1 mm	d mm	Locking Pin	Locking Ring	Pieces	Weight/g
0789010305100	789IN-3	48	20	19	7893-15	7894-15	6	35
0789010405100	789IN-4	48	20	19	7893-15	7894-15	6	35
0789010505100	789IN-5	48	20	19	7893-15	7894-15	6	40
0789010605100	789IN-6	48	20	19	7893-15	7894-15	6	40
0789010805100	789IN-8	55	25	19	7893-15	7894-15	6	55
0789011005100	789IN-10	60	28	19	7893-15	7894-15	6	70
0789011205100	789IN-12	65	31	19	7893-15	7894-15	6	90

Spare blades on request

7906-...

IMPACT EXTENSION BAR 3/8"

- for power tools
- special steel, phosphated
- square according to DIN 3121, form F and G, ISO 1174



10

3/8"

Code	Number	l/mm	Locking Pin	Locking Ring	Pieces	Weight/g
7906000755100	7906-75	75	7893-15	7894-15	6	87
7906001505100	7906-150	150	7893-15	7894-15	3	180
7906002505100	7906-250	250	7893-15	7894-15	3	286

You will find the matching socket rails on page no. 143



795-3/8

IMPACT UNIVERSAL JOINT 3/8"

- for power tools
- special steel, phosphated
- square according to DIN 3121, form F and G, ISO 1174



10

3/8"

Code	Number	l/mm	Locking Pin	Locking Ring	Pieces	Weight/g
0795100195100	795-3/8	50	7893-18	7894-18	3	67

7902-.../7905-.../7907-...

IMPACT ADAPTOR

- for power tools
- special steel, phosphated
- square according to DIN 3121, form F, G and H, ISO 1174



10

3/8"

Code	Number	Ø	□	l/mm	Locking Pin	Locking Ring	Pieces	Weight/g
7907100195100	7907-3/8	1/4"	3/8"	25	7883-11	7884-11	3	20
7905100235100	7905-1/2	3/8"	1/2"	32	7893-21	7894-20	3	75
7902100195100	7902-3/8	1/2"	3/8"	36	7903-20	7904-20	3	65

3426

IMPACT ADAPTOR

- for power tools
- with 1/4" outside hexagon according to DIN 3126-E 6,3, DIN ISO 1173
- special steel
- male square drive according to DIN 3121-E 10, ISO 1174, with locking pin
- according to DIN 7428, ISO 3317



10

3/8"

Code	Number	l/mm	□	Ø	Pieces	Weight/g
3426000000000	3426	50	3/8"	1/4"	6	52

7893-.../7894-...

IMPACT LOCKING PIN AND RING FOR IMPACT SOCKET 3/8"

- for locking impact sockets and operating tools
- locking pin made of alloyed special steel
- locking ring made of rubber elastic and oil resistant material



Code	Number	l/mm	mm Ø	Pieces	Weight/g
7893000155100	7893-15	15	2,5	12	0,60
7893000185100	7893-18	18	2,5	12	0,75
7893000215100	7893-21	21	3,0	12	0,80
7894000155100	7894-15	-	15	12	0,30
7894000185100	7894-18	-	18	12	0,35
7894000205100	7894-20	-	20	12	0,30

790-..., 790A-....

IMPACT SOCKET 1/2", HEXAGON

- for power tools
- special steel, phosphated
- female square drive according to DIN 3121-G 12,5, ISO1174
- according to DIN 3129, ISO 2725-2

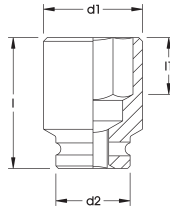

Code	Number	l/mm	l1 mm	d1 mm	d2 mm	Locking Pin	Locking Ring	Pieces	Weight/g
0790000105100	790-10	36	7	17,5	25	7903-20	7904-20	6	90
0790000115100	790-11	36	7	18,5	25	7903-20	7904-20	6	90
0790000125100	790-12	36	8	20	25	7903-20	7904-20	6	95
0790000135100	790-13	36	8	21	25	7903-20	7904-20	6	88
0790000145100	790-14	37	9	22,5	25	7903-20	7904-20	6	90
0790000155100	790-15	37	9	23,5	30	7903-25	7904-24	6	135
0790000165100	790-16	37	10	25	30	7903-25	7904-24	6	135
0790000175100	790-17	37	10	26	30	7903-25	7904-24	6	140
0790000185100	790-18	38	11	27,5	30	7903-25	7904-24	6	137
0790000195100	790-19	38	12	28,5	30	7903-25	7904-24	6	130
0790000205100	790-20	38	12	30	30	7903-25	7904-24	6	130
0790000215100	790-21	39	13	31	30	7903-25	7904-24	6	130
0790000225100	790-22	39	14	32,5	30	7903-25	7904-24	6	150
0790000235100	790-23	39	15	33,5	30	7903-25	7904-24	6	180
0790000245100	790-24	42	16	35	30	7903-25	7904-24	6	185
0790000255100	790-25	42	16	36	30	7903-25	7904-24	6	215
0790000265100	790-26	42	17	37,5	30	7903-25	7904-24	6	225
0790000275100	790-27	45	18	38,5	30	7903-25	7904-24	6	230
0790000285100	790-28	45	18	40	30	7903-25	7904-24	6	255
0790000295100	790-29	45	19	41	30	7903-25	7904-24	6	245
0790000305100	790-30	49	20	42,5	30	7903-25	7904-24	6	250
0790000325100	790-32	49	21	45	30	7903-25	7904-24	6	250
0790000345100	790-34	51	22	47,5	30	7903-25	7904-24	6	275



Code	Number	l/mm	l1 mm	d1 mm	d2 mm	Locking Pin	Locking Ring	Pieces	Weight/g
0790100195100	790A-3/8	35	5	16,5	25	7903-20	7904-20	6	90
0790100215100	790A-7/16	35	7	18	25	7903-20	7904-20	6	90
0790100235100	790A-1/2	35	7	20	25	7903-20	7904-20	6	88
0790100245100	790A-9/16	35	8	22	25	7903-20	7904-20	6	135
0790100265100	790A-5/8	35	9	24	30	7903-25	7904-24	6	135
0790100275100	790A-11/16	35	10	26	30	7903-25	7904-24	6	137
0790100285100	790A-3/4	35	11	29	30	7903-25	7904-24	6	130
0790100305100	790A-13/16	38	13	31	30	7903-25	7904-24	6	130
0790100315100	790A-7/8	38	14	33	30	7903-25	7904-24	6	150
0790100325100	790A-15/16	38	15	35	36	7903-30	7904-30	6	185
0790100345100	790A-1	38	16	37	36	7903-30	7904-30	6	225
0790100355100	790A-1. 1/16	40	16	39	36	7903-30	7904-30	6	225
0790100365100	790A-1.1/8	50	18	41	36	7903-30	7904-30	6	255
0790100385100	790A-1 1/4	50	19	44	36	7903-30	7904-30	6	250
0790100395100	790A-1.5/16	50	20	46	36	7903-30	7904-30	6	290

790LT-...

IMPACT SOCKET 1/2", EXTRA DEEP, HEXAGON

- for power tools
- special steel, phosphated
- female square drive according to DIN 3121-G 12,5, ISO 1174

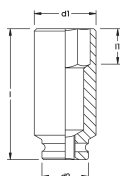

12,5

1/2"



Code	Number	l/mm	l1 mm	d1 mm	d2 mm	Locking Pin	Locking Ring	Pieces	Weight/g
0790020105100	790LT-10	85	12	17	25	7903-20	7904-20	6	155
0790020135100	790LT-13	85	14	21	25	7903-20	7904-20	6	160
0790020145100	790LT-14	85	15	22,5	25	7903-20	7904-20	6	185
0790020165100	790LT-16	85	15	25	30	7903-25	7904-24	6	210
0790020175100	790LT-17	85	15	26	30	7903-25	7904-24	6	230
0790020185100	790LT-18	85	16	27	30	7903-25	7904-24	6	240
0790020195100	790LT-19	85	16	28,5	30	7903-25	7904-24	3	250
0790020205100	790LT-20	85	19	30	30	7903-25	7904-24	3	260
0790020215100	790LT-21	85	19	31	30	7903-25	7904-24	3	275
0790020225100	790LT-22	85	19	32,5	30	7903-25	7904-24	3	300
0790020245100	790LT-24	85	21	35	30	7903-25	7904-24	3	370
0790020275100	790LT-27	85	23	38	30	7903-25	7904-24	3	430
0790020305100	790LT-30	85	25	42	30	7903-25	7904-24	3	510
0790020325100	790LT-32	85	25	44	30	7903-25	7904-24	3	560



Code	Number	l/mm	l1 mm	d1 mm	d2 mm	Locking Pin	Locking Ring	Pieces	Weight/g
0790120195100	790LTA-3/8	78	4	16	25	7903-20	7904-20	6	140
0790120215100	790LTA-7/16	78	6	18	25	7903-20	7904-20	6	140
0790120235100	790LTA-1/2	78	6	20	25	7903-20	7904-20	6	140
0790120245100	790LTA-9/16	78	7	22	25	7903-25	7904-24	6	200
0790120265100	790LTA-5/8	78	8	25	25	7903-25	7904-24	6	200
0790120275100	790LTA-11/16	78	9	25	25	7903-25	7904-24	6	190
0790120285100	790LTA-3/4	78	9,5	28	30	7903-25	7904-24	3	250
0790120305100	790LTA-13/16	78	11	30	30	7903-25	7904-24	3	280
0790120315100	790LTA-7/8	78	13	32	30	7903-25	7904-24	3	280
0790120325100	790LTA-15/16	78	13	35	30	7903-25	7904-24	3	300
0790120345100	790LTA-1	78	13	35	30	7903-25	7904-24	3	380
0790120355100	790LTA-1.1/16	78	13	38	30	7903-25	7904-24	3	430
0790120365100	790LTA-1.1/8	78	16,5	38	30	7903-25	7904-24	3	480
0790120385100	790LTA-1.1/4	78	17	44	35	7903-25	7904-24	3	500
0790120395100	790LTA-1.5/16	78	19	45	35	7903-25	7904-24	3	550

You will find Impact Sockets 1/2" thin walled on page no. 443



790MG-...

IMPACT SOCKET 1/2", WITH MAGNETIC INSERT, HEXAGON

- for power tools
- special steel, gunmetal-finish
- female square drive according to DIN 3121-G 12,5, ISO 1174
- according to DIN 3129, ISO 2725-2

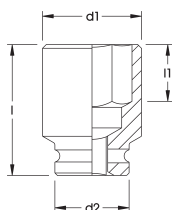

12,5



1/2"



Code	Number	l/mm	l1 mm	d1 mm	d2 mm	Locking Pin	Locking Ring	Pieces	Weight/g
0790016105100	790MG-10	38	5	17	25	7903-20	7904-20	6	92
0790016115100	790MG-11	38	5	19	25	7903-20	7904-20	6	92
0790016125100	790MG-12	38	6	20	25	7903-20	7904-20	6	92
0790016135100	790MG-13	38	6	21	25	7903-20	7904-20	6	92
0790016145100	790MG-14	38	7	22,5	25	7903-20	7904-20	6	92
0790016155100	790MG-15	38	7	23,7	30	7903-25	7904-24	6	132
0790016165100	790MG-16	38	8	25	30	7903-25	7904-24	6	132
0790016175100	790MG-17	38	9	26	30	7903-25	7904-24	6	132
0790016185100	790MG-18	38	9	27,5	30	7903-25	7904-24	6	132
0790016195100	790MG-19	38	9,5	28,7	30	7903-25	7904-24	6	132

798-E...

IMPACT SOCKET 1/2"

- for outside TORX® screws
- for power tools
- special steel, phosphated
- female square according to DIN 3121-G 12,5, ISO 1174
- TORX® = reg. trademark of Acument Intellectual Properties, LLC. USA

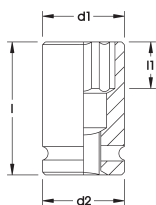

12,5

1/2"

Code	Number	l/mm	l1 mm	d1 mm	d2 mm	Locking Pin	Locking Ring	Pieces	Weight/g	
0798000105000	798-E10	9,42	38	9	15	25	7903-20	7904-20	6	84
0798000125000	798-E12	11,17	38	10	16	25	7903-20	7904-20	6	85
0798000145000	798-E14	12,90	38	12	18,5	25	7903-20	7904-20	6	86
0798000185000	798-E18	16,70	38	12	22	25	7903-20	7904-20	6	90
0798000205000	798-E20	18,45	38	13	25	30	7903-25	7904-24	6	128
0798000245000	798-E24	22,16	38	17	28,5	30	7903-25	7904-24	6	142

790IN-..., 790INA-...

IMPACT SCREWDRIVER SOCKET 1/2"

- for inside hexagon screws
- with exchangeable blades
- for power tools
- special steel, phosphated
- female square drive according to DIN 3121-G 12,5, ISO 1174

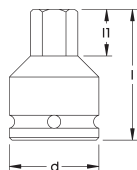

12,5

1/2"



Code	Number	l/mm	l1 mm	d mm	Locking Pin	Locking Ring	Pieces	Weight/g
0790010505100	790IN-5	54	8	25	7903-20	7904-20	6	90
0790010605100	790IN-6	54	9	25	7903-20	7904-20	6	100
0790010805100	790IN-8	57	12	25	7903-20	7904-20	6	100
0790011005100	790IN-10	57	16	25	7903-20	7904-20	6	100
0790011205100	790IN-12	57	18	30	7903-25	7904-24	6	150
0790011405100	790IN-14	57	21	30	7903-25	7904-24	6	150
0790011705100	790IN-17	57	26	30	7903-25	7904-24	6	150
0790011905100	790IN-19	72	26	30	7903-25	7904-24	6	150



Code	Number	l/mm	l1 mm	d mm	Locking Pin	Locking Ring	Pieces	Weight/g
0790110065100	790INA-1/8	54	6	25	7903-20	7904-20	6	90
0790110085100	790INA-5/32	54	6	25	7903-20	7904-20	6	90
0790110095100	790INA-3/16	54	8	25	7903-20	7904-20	6	90
0790110115100	790INA-7/32	54	9	25	7903-20	7904-20	6	90
0790110135100	790INA-1/4	57	12	25	7903-20	7904-20	6	100
0790110175100	790INA-5/16	57	12	25	7903-20	7904-20	6	100
0790110195100	790INA-3/8	57	16	25	7903-20	7904-20	6	100
0790110215100	790INA-7/16	57	18	25	7903-20	7904-20	6	100
0790110235100	790INA-1/2	57	19	30	7903-25	7904-24	6	150
0790110245100	790INA-9/16	57	21	30	7903-25	7904-24	6	150
0790110265100	790INA-5/8	57	24	30	7903-25	7904-24	6	150

Spare blades on request

790TX-...

IMPACT SCREWDRIVER SOCKET 1/2"

- for inside TORX® screws
- exchangeable blades
- for power tools
- special steel, gunmetal-finish
- female square drive according to DIN 3121-G 12,5, ISO 1174
- TORX® = reg. trademark of Acument Intellectual Properties, LLC. USA

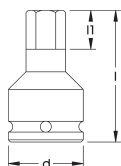

12,5

1/2"

Code	Number	★ mm	l/mm	l1 mm	d mm	Locking Pin	Locking Ring	Pieces	Weight/g
0790015305100	790TX-30	5,52	57	3,19	25	7903-20	7904-20	6	110
0790015405100	790TX-40	6,65	57	3,30	25	7903-20	7904-20	6	110
0790015505100	790TX-50	8,83	57	4,57	25	7903-20	7904-20	6	110
0790015555100	790TX-55	11,22	57	5,08	25	7903-20	7904-20	6	110
0790015605100	790TX-60	13,25	60	7,62	30	7903-25	7904-24	6	170
0790015705100	790TX-70	15,53	70	8,89	30	7903-25	7904-24	6	180

Spare blades on request

7901-...

IMPACT EXTENSION BAR 1/2"

- ▶ for power tools
- ▶ special steel, phosphated
- ▶ female square according to DIN 3121, form F and G, ISO 1174



12,5

1/2"

Code	Number	l/mm	Locking Pin	Locking Ring	Pieces	Weight/g
7901001255100	7901-125	125	7903-20	7904-20	3	270
7901002505100	7901-250	250	7903-20	7904-20	3	540

795-1/2

IMPACT UNIVERSAL JOINT 1/2"

- ▶ for power tools
- ▶ special steel, phosphated
- ▶ female square according to DIN 3121, form F and G, ISO 1174



12,5

1/2"

Code	Number	l/mm	Locking Pin	Locking Ring	Pieces	Weight/g
0795100235100	795-1/2	65	7903-25	7904-24	3	170

7902-.../7912-...

IMPACT ADAPTOR

- ▶ for power tools
- ▶ special steel, phosphated
- ▶ square according to DIN 3121, form F, G and H, ISO 1174



12,5

1/2"

Code	Number	□	■	l/mm	Locking Pin	Locking Ring	Pieces	Weight/g
7905100235100	7905-1/2	3/8"	1/2"	32	7893-21	7894-20	3	75
7902100195100	7902-3/8	1/2"	3/8"	36	7903-20	7904-20	3	65
7902100285100	7902-3/4	1/2"	3/4"	50	7903-25	7904-24	3	162
7912100235100	7912-1/2	3/4"	1/2"	57	7913-29	7914-28	3	235

You will find the matching socket rails on page no. 161



3427

IMPACT ADAPTOR

- for power tools
- with 1/4" outside hexagon according to DIN 3126-E 6,3, ISO 1173
- special steel
- male square drive according to DIN 3121-E 12,5, DIN ISO 1174, with locking pin
- according to DIN 7428, ISO 3317



12,5

1/2"

Code	Number	l/mm ┌──┐			Pieces 	Weight/g
3427000000000	3427	75	1/2"	1/4"	6	100

7903-.../7904-...

IMPACT LOCKING PIN AND RING FOR IMPACT SOCKETS 1/2"

- for locking impact sockets and operating tools
- locking pin made of alloyed special steel
- locking ring made of rubber elastic and oil resistant material



Code	Number	l/mm ┌──┐	mm ∅	Pieces 	Weight/g
7903000205100	7903-20	20	3,0	12	0,75
7903000255100	7903-25	25	3,0	12	0,80
7903000305100	7903-30	30	3,0	12	1,00
7904000205100	7904-20	-	20	12	0,50
7904000245100	7904-24	-	24	12	1,00
7904000305100	7904-30	-	30	12	1,50

790 S6...

IMPACT SOCKET SET 1/2"

- for power tools
- in black metal storage case with OMS-hard foam insert
- tools made of special steel, phosphated
- square according to DIN 3121, form F and G, ISO1174



Code	Number	Contents	Pieces	Weight/g
0790500605100	790 S6	Impact Sockets 1/2": 790- 10, 13, 17, 19, 24 mm Impact Extension Bar 1/2"; 7901-125	1	1262
0790600605100	790 S6A	Impact Sockets 1/2": 790A- 3/8, 1/2, 7/8, 3/4, 15/16" AF Impact Extension Bar 1/2": 7901-125	1	1300

790 S6LT

IMPACT SOCKET SET 1/2"

- for power tools
- in black metal storage case with OMS-hard foam insert
- square according to DIN 3121, form F and G, ISO1174
- tools made of special steel, phosphated

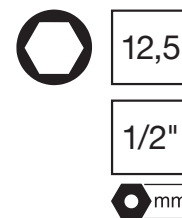

Code	Number	Contents	Pieces	Weight/g
0790520605100	790 S6LT	Impact Sockets, extra deep 1/2": 790LT- 10, 13, 17, 19, 24 mm Impact Extension Bar 1/2"; 7901-125	1	1880

790 S12...

IMPACT SOCKET SET 1/2"

- for power tools
- in black metal storage case with OMS-hard foam insert
- square according to DIN 3121, form F and G, ISO1174
- tools made of special steel, phosphated



Code	Number	Contents	Pieces	Weight/g
0790501205100	790 S12	Impact Sockets, 1/2": 790- 10, 11, 13, 14, 17, 19, 21, 22, 23, 24 mm Impact Extension Bar 1/2", 7901-125 Impact Universal Joint 1/2", 795-1/2	1	2500
0790601205100	790 S12A	Impact Sockets, 1/2": 790A- 3/8, 7/16, 1/2, 9/16, 5/8, 11/16, 3/4, 7/8, 15/16, 1" AF Impact Extension Bar 1/2", 7901-125 Impact Universal Joint 1/2", 795-1/2	1	2400

You will find the matching OMS-24 module on page no. 33



791-..., 791A-...

IMPACT SOCKET 3/4", HEXAGON

- for power tools
- special steel, phosphated
- female square drive according to DIN 3121-H 20, ISO 1174
- according to DIN 3129, ISO 2725-2

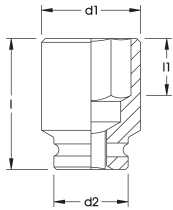

20

3/4"



Code	Number	l/mm	l1 mm	d1 mm	d2 mm	Locking Pin	Locking Ring	Pieces	Weight/g
0791000175100	791-17	50	10	30	44	7913-37	7914-36	3	365
0791000195100	791-19	50	12	32,5	44	7913-37	7914-36	3	370
0791000215100	791-21	51	13	35	44	7913-37	7914-36	3	380
0791000225100	791-22	51	14	37,5	44	7913-37	7914-36	3	395
0791000245100	791-24	52	16	39	44	7913-37	7914-36	3	380
0791000255100	791-25	52	16	40	44	7913-37	7914-36	3	380
0791000265100	791-26	53	17	41,5	44	7913-37	7914-36	3	370
0791000275100	791-27	53	18	42,5	44	7913-37	7914-36	3	385
0791000285100	791-28	53	18	44	44	7913-37	7914-36	3	390
0791000295100	791-29	53	19	45	44	7913-37	7914-36	3	390
0791000305100	791-30	53	20	46,5	44	7913-37	7914-36	3	390
0791000325100	791-32	56	21	49	44	7913-37	7914-36	1	471
0791000335100	791-33	56	21	50	44	7913-37	7914-36	1	496
0791000345100	791-34	56	22	51,5	44	7913-37	7914-36	1	511
0791000365100	791-36	56	24	54	44	7913-37	7914-36	1	529
0791000385100	791-38	56	25	56,5	44	7913-37	7914-36	1	584
0791000415100	791-41	57	26	60	44	7913-37	7914-36	1	607
0791000465100	791-46	62	28	66,5	44	7913-37	7914-36	1	750



Code	Number	l/mm	l1 mm	d1 mm	d2 mm	Locking Pin	Locking Ring	Pieces	Weight/g
0791100285100	791A-3/4	50	12	31,5	44	7913-37	7914-36	3	370
0791100305100	791A-13/16	50	14	34	44	7913-37	7914-36	3	380
0791100315100	791A-7/8	50	16	36	44	7913-37	7914-36	3	395
0791100325100	791A-15/16	50	16	38	44	7913-37	7914-36	3	380
0791100345100	791A-1	53	18	40	44	7913-37	7914-36	3	380
0791100355100	791A-1.1/16	53	18	42	44	7913-37	7914-36	3	385
0791100365100	791A-1.1/8	53	20	44	44	7913-37	7914-36	3	390
0791100375100	791A-1.3/16	53	20	46	44	7913-37	7914-36	3	390
0791100385100	791A-1.1/4	56	20	48	44	7913-37	7914-36	1	479
0791100395100	791A-1.5/16	56	23	50	44	7913-37	7914-36	1	494
0791100405100	791A-1.3/8	56	23	52	44	7913-37	7914-36	1	518
0791100415100	791A-1.7/16	56	23	54	44	7913-37	7914-36	1	558
0791100425100	791A-1.1/2	56	25	56	44	7913-37	7914-36	1	583
0791100445100	791A-1.5/8	57	25	59	44	7913-37	7914-36	1	628
0791110455100	791A-1.11/16	57	29	63,5	44	7913-37	7914-36	1	720
0791110465100	791A-1.3/4	57	29	65	54	7913-45	7914-46	1	850
0791110485100	791A-1.7/8	62	29	68	54	7913-45	7914-46	1	899
0791110495100	791A-2	65	29	72	54	7913-45	7914-46	1	1040

04

791LT-...

IMPACT SOCKET 3/4", EXTRA DEEP, HEXAGON

- for power tools
- special steel, phosphated
- female square drive according to DIN 3121-H 20, ISO 1174

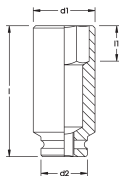

20

3/4"

mm

Code	Number	l/mm	l1 mm	d1 mm	d2 mm	Locking Pin	Locking Ring	Pieces	Weight/g
0791020175100	791LT-17	100	15	30	44	7913-37	7914-36	1	603
0791020195100	791LT-19	100	17	32,5	44	7913-37	7914-36	1	620
0791020225100	791LT-22	100	19	36,5	44	7913-37	7914-36	1	695
0791020245100	791LT-24	100	21	39	44	7913-37	7914-36	1	745
0791020275100	791LT-27	100	23	42,5	44	7913-37	7914-36	1	828
0791020305100	791LT-30	100	25	46,5	44	7913-37	7914-36	1	869
0791020325100	791LT-32	100	26	49	44	7913-37	7914-36	1	921
0791020335100	791LT-33	100	26	50	44	7913-37	7914-36	1	984
0791020345100	791LT-34	100	27	51,5	44	7913-37	7914-36	1	1001
0791020365100	791LT-36	100	29	54	44	7913-37	7914-36	1	1050
0791020385100	791LT-38	100	30	56,5	44	7913-37	7914-36	1	1187
0791020415100	791LT-41	100	31	60	44	7913-37	7914-36	1	1272
0791020465100	791LT-46	100	33	66,5	44	7913-37	7914-36	1	1581
0791020505100	791LT-50	90	27	70	54	7913-37	7914-36	1	1400
0791020555100	791LT-55	94	30	78	54	7913-37	7914-36	1	1800
0791020605100	791LT-60	98	33	82	54	7913-37	7914-36	1	1900
0791020655100	791LT-65	105	38	86	54	7913-37	7914-36	1	2000



Code	Number	l/mm	l1 mm	d1 mm	d2 mm	Locking Pin	Locking Ring	Pieces	Weight/g
0791120285100	791LTA-3/4	90	9,5	32	44	7913-37	7914-36	1	750
0791120305100	791LTA-13/16	90	11	35	44	7913-37	7914-36	1	750
0791120315100	791LTA-7/8	90	13	38	44	7913-37	7914-36	1	750
0791120325100	791LTA-15/16	90	13	40	44	7913-37	7914-36	1	750
0791120345100	791LTA-1	90	13	41	44	7913-37	7914-36	1	750
0791120355100	791LTA-1.1/16	90	13	41	44	7913-37	7914-36	1	750
0791120365100	791LTA-1.1/8	90	16,5	44	44	7913-37	7914-36	1	690
0791120375100	791LTA-1.3/16	90	16,5	44	44	7913-37	7914-36	1	690
0791120385100	791LTA-1.1/4	90	17	49	44	7913-37	7914-36	1	780
0791120395100	791LTA-1.5/16	90	19	49	44	7913-37	7914-36	1	740
0791120405100	791LTA-1.3/8	90	19	52	44	7913-37	7914-36	1	875
0791120415100	791LTA-1.7/16	90	19	52	44	7913-37	7914-36	1	800
0791120425100	791LTA-1.1/2	90	22	54	44	7913-37	7914-36	1	850
0791120445100	791LTA-1.5/8	90	22	57	44	7913-37	7914-36	1	840
0791120455100	791LTA-1.11/16	90	25	63	44	7913-37	7914-36	1	1020
0791120465100	791LTA-1.3/4	90	25,5	63	44	7913-37	7914-36	1	1020
0791120485100	791LTA-1.7/8	90	27	67	54	7913-37	7914-36	1	1235
0791120495100	791LTA-2	90	27	73	54	7913-37	7914-36	1	1500

791IN-..., 791INA-...

IMPACT SOCKET 3/4"

- ▶ for power tools
- ▶ for inside hexagon screws
- ▶ with exchangeable blades
- ▶ special steel, phosphated
- ▶ female square according to DIN 3121-H 20, ISO 1174

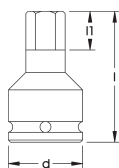

20

3/4"

Code	Number	l/mm	l1 mm	d mm	Locking Pin	Locking Ring	Pieces	Weight/g
0791010105100	791IN-10	69	16	38	7913-37	7914-36	3	310
0791010125100	791IN-12	69	18	38	7913-37	7914-36	3	310
0791010145100	791IN-14	69	21	38	7913-37	7914-36	3	310
0791010175100	791IN-17	69	26	38	7913-37	7914-36	3	310
0791010195100	791IN-19	84	26	44	7913-37	7914-36	3	630
0791010225100	791IN-22	84	26	44	7913-37	7914-36	3	630
0791010245100	791IN-24	84	26	44	7913-37	7914-36	3	630



Code	Number	l/mm	l1 mm	d mm	Locking Pin	Locking Ring	Pieces	Weight/g
0791110195100	791INA-3/8	72	16	38	7913-29	7914-28	3	310
0791110215100	791INA-7/16	72	18	38	7913-29	7914-28	3	310
0791110235100	791INA-1/2	72	19	38	7913-29	7914-28	3	310
0791110245100	791INA-9/16	72	21	38	7913-29	7914-28	3	310
0791110265100	791INA-5/8	74	24	38	7913-29	7914-28	3	310
0791110285100	791INA-3/4	84	26	44	7913-37	7914-36	3	630
0791110305100	791INA-13/16	84	26	44	7913-37	7914-36	3	630
0791110315100	791INA-7/8	84	26	44	7913-37	7914-36	3	630
0791110345100	791INA-1	91	30	44	7913-37	7914-36	3	630

7911-...

IMPACT EXTENSION BAR 3/4"

- ▶ for power tools
- ▶ special steel, phosphated
- ▶ square drive according to DIN 3121, form F and H, ISO 1174



20

3/4"

Code	Number	l/mm	Locking Pin	Locking Ring	Pieces	Weight/g
7911001755100	7911-175	175	7913-37	7914-36	1	865
7911002505100	7911-250	250	7913-37	7914-36	1	1151
7911003255100	7911-325	325	7913-37	7914-36	1	1452

795-3/4

IMPACT UNIVERSAL JOINT 3/4"

- ▶ for power tools
- ▶ special steel, phosphated
- ▶ square drive according to DIN 3121, Form F and H, ISO 1174



20

3/4"

Code	Number	l/mm	Locking Pin	Locking Ring	Pieces	Weight/g
0795100285100	795-3/4	105	7913-37	7914-36	1	606

7902-.../7912-.../7922-...

IMPACT ADAPTOR

- ▶ for power tools
- ▶ special steel, phosphated
- ▶ square according to DIN 3121, form F, G and H, ISO 1174



20

3/4"

Code	Number	□	□	l/mm	Locking Pin	Locking Ring	Pieces	Weight/g
7902100285100	7902-3/4	1/2"	3/4"	50	7903-25	7904-24	3	162
7912100235100	7912-1/2	3/4"	1/2"	57	7913-37	7914-36	3	235
7912100345100	7912-1	3/4"	1"	62	7913-37	7914-36	3	340
7922100285100	7922-3/4	1"	3/4"	75	7923-42	7924-41	1	548

7913-.../7914-...

IMPACT LOCKING PIN AND RING FOR IMPACT SOCKET 3/4"

- ▶ for locking impact sockets and operating tools
- ▶ locking pin made of alloyed special steel
- ▶ locking ring made of rubber elastic and oil resistant material



Code	Number	l/mm	mm Ø	Pieces	Weight/g
7913000295100	7913-29	29	4,0	12	3,0
7913000375100	7913-37	37	4,0	12	3,8
7913000455100	7913-45	45	4,0	12	4,5
7914000285100	7914-28	-	28	12	1,2
7914000365100	7914-36	-	36	12	1,4
7914000465100	7914-46	-	46	12	1,6

791 S6LT

IMPACT SOCKET SET 3/4"

- ▶ for power tools
- ▶ in black metal storage case with OMS-hard foam insert
- ▶ female square drive according to DIN 3121-H 20, ISO1174
- ▶ tools made of special steel, phosphated



20

3/4"



mm

Code	Number	Contents	Pieces	Weight/g
0791520605100	791 S6LT	Impact Sockets, extra deep 3/4"; 791LT- 24, 27, 30, 32, 36, 41 mm	1	7360

791 S5...

IMPACT SOCKET SET 3/4"

- ▶ for power tools
- ▶ in black metal storage case with OMS-hard foam insert
- ▶ female square drive according to DIN 3121-H 20, ISO 1174
- ▶ tools made of special steel, phosphated



20

3/4"



mm



AF"

Code	Number	Contents	Pieces	Weight/g
0791500505100	791 S5	Impact Sockets 3/4"; 791- 19, 24, 27, 30, 32 mm	1	2850
0791600505100	791 S5A	Impact Sockets 3/4"; 791A- 3/4, 15/16, 1.1/16, 1-3/16, 1.5/16" AF	1	2800

791 S10...

IMPACT SOCKET SET 3/4"

- ▶ for power tools
- ▶ in black metal storage case with OMS-hard foam insert
- ▶ female square drive according to DIN 3121-H 20, ISO1174
- ▶ tools made of special steel, phosphated



20

3/4"



mm



AF"

Code	Number	Contents	Pieces	Weight/g
0791501005100	791 S10	Impact Sockets 3/4": 791- 17, 19, 22, 24, 27, 30, 32, 36, 41, 46 mm	1	6160
0791601005100	791 S10A	Impact Sockets 3/4": 791- 3/4, 7/8, 15/16, 1.1/16, 1.3/16, 1.5/16, 1.7/16, 1.5/8, 1.3/4, 1.7/8" AF	1	6160

You will find the matching OMS-23 module on page no. 33



792-..., 792A-...

IMPACT SOCKET 1", HEXAGON

- for power tools
- special steel, phosphated
- female square drive according to DIN 3121-H 25, ISO 1174
- according to DIN 3129, ISO 2725-2

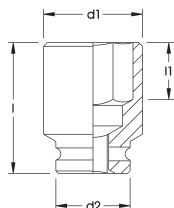

25

1"



Code	Number	l/mm	l1 mm	d1 mm	d2 mm	Locking Pin	Locking Ring	Pieces	Weight/g
0792000195100	792-19	56	12	35,5	54	7923-45	7924-44	1	684
0792000215100	792-21	56	13	38	54	7923-45	7924-44	1	667
0792000225100	792-22	56	14	39,5	54	7923-45	7924-44	1	672
0792000245100	792-24	57	16	42	54	7923-45	7924-44	1	696
0792000255100	792-25	58	17	43	54	7923-45	7924-44	1	706
0792000265100	792-26	58	17	44,5	54	7923-45	7924-44	1	703
0792000275100	792-27	59	18	45,5	54	7923-45	7924-44	1	691
0792000285100	792-28	58	19	46	54	7923-45	7924-44	1	690
0792000295100	792-29	60	19	48	54	7923-45	7924-44	1	693
0792000305100	792-30	61	20	49,5	54	7923-45	7924-44	1	691
0792000325100	792-32	61	21	52	54	7923-45	7924-44	1	692
0792000335100	792-33	61	21	53	54	7923-45	7924-44	1	686
0792000345100	792-34	62	22	54,5	54	7923-45	7924-44	1	685
0792000365100	792-36	64	24	57	54	7923-45	7924-44	1	746
0792000385100	792-38	64	25	59,5	54	7923-45	7924-44	1	771
0792000415100	792-41	68	26	63	54	7923-45	7924-44	1	787
0792000425100	792-42	68	26	64,5	54	7923-45	7924-44	1	836
0792000465100	792-46	72	28	69,5	54	7923-45	7924-44	1	1133
0792000505100	792-50	76	31	74,5	54	7923-45	7924-44	1	1208
0792000525100	792-52	76	31	76	54	7923-45	7924-44	1	1298
0792000555100	792-55	80	33	80,5	54	7923-45	7924-44	1	1399
0792000605100	792-60	85	36	87	54	7923-45	7924-44	1	1687
0792000655100	792-65	90	39	93	54	7923-45	7924-44	1	2004
0792000705100	792-70	95	41	99,5	54	7923-45	7924-44	1	2280



Code	Number	l/mm	l1 mm	d1 mm	d2 mm	Locking Pin	Locking Ring	Pieces	Weight/g
0792100285100	792A-3/4	55	9,5	35	54	7923-45	7924-44	1	582
0792100325100	792A-15/16	55	13	41	54	7923-45	7924-44	1	580
0792100345100	792A-1	55	13	43	54	7923-45	7924-44	1	641
0792100365100	792A-1.1/8	57	16,5	48	54	7923-45	7924-44	1	630
0792100385100	792A-1.1/4	57	17	51	54	7923-45	7924-44	1	630
0792100395100	792A-1.5/16	60	19	54	54	7923-45	7924-44	1	679
0792100405100	792A-1.3/8	60	19	54	54	7923-45	7924-44	1	659
0792100415100	792A-1.7/16	60	19	54	54	7923-45	7924-44	1	631
0792100425100	792A-1.1/2	64	22	60	54	7923-45	7924-44	1	797
0792100445100	792A-1.5/8	64	22	63	54	7923-45	7924-44	1	821
0792100475100	792A-1.13/16	69	25,5	70	54	7923-45	7924-44	1	1013
0792100485100	792A-1.7/8	72	27	70	54	7923-45	7924-44	1	1000
0792100495100	792A-2	72	27	73	54	7923-45	7924-44	1	1080
0792100525100	792A-2.3/16	80	32	82	54	7923-45	7924-44	1	1413
0792100535100	792A-2.1/4	80	33	82	54	7923-45	7924-44	1	1405

792LT-...

IMPACT SOCKET 1", EXTRA DEEP, HEXAGON

- for power tools
- special steel, phosphated
- female square drive according to DIN 3121-H 25, ISO 1174
- inch sizes on request resp. see price list

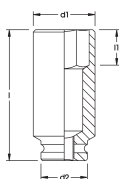

25

1"



Code	Number	l/mm H	l1 mm	d1 mm	d2 mm	Locking Pin	Locking Ring	Pieces ☞	Weight/g ⚖
0792020215100	792LT-21	110	18	38	54	7923-45	7924-44	1	957
0792020225100	792LT-22	110	19	39,5	54	7923-45	7924-44	1	973
0792020245100	792LT-24	110	21	42	54	7923-45	7924-44	1	1036
0792020275100	792LT-27	110	23	45,5	54	7923-45	7924-44	1	1075
0792020305100	792LT-30	110	25	49,5	54	7923-45	7924-44	1	1136
0792020325100	792LT-32	110	26	52	54	7923-45	7924-44	1	1208
0792020335100	792LT-33	110	26	53	54	7923-45	7924-44	1	1216
0792020345100	792LT-34	110	27	54,5	54	7923-45	7924-44	1	1236
0792020365100	792LT-36	110	29	57	54	7923-45	7924-44	1	1293
0792020385100	792LT-38	110	30	59,5	54	7923-45	7924-44	1	1398
0792020415100	792LT-41	110	31	63	54	7923-45	7924-44	1	1477
0792020465100	792LT-46	110	33	69,5	54	7923-45	7924-44	1	1798
0792020505100	792LT-50	110	36	74,5	54	7923-45	7924-44	1	2000
0792020555100	792LT-55	110	38	80,5	54	7923-45	7924-44	1	2200
0792020605100	792LT-60	110	41	87	54	7923-45	7924-44	1	2540
0792020655100	792LT-65	110	44	93	54	7923-45	7924-44	1	3000
0792020705100	792LT-70	110	46	99,5	54	7923-45	7924-44	1	3000
0792020755100	792LT-75	120	48	105,5	86	7933-75	7934-75	1	4790
0792020805100	792LT-80	125	51	112	86	7933-75	7934-75	1	5390
0792020855100	792LT-85	130	54	118	86	7933-75	7934-75	1	5990
0792020905100	792LT-90	135	57	124,5	86	7933-75	7934-75	1	6700
0792020955100	792LT-95	140	60	130,5	86	7933-75	7934-75	1	7410
0792021005100	792LT-100	140	63	137	86	7933-75	7934-75	1	7860



Code	Number	l/mm H	l1 mm	d1 mm	d2 mm	Locking Pin	Locking Ring	Pieces ☞	Weight/g ⚖
0792120285100	792LTA-3/4	100	9,5	36	54	7923-45	7924-44	1	1200
0792120325100	792LTA-15/16	100	13	41	54	7923-45	7924-44	1	1200
0792120345100	792LTA-1	100	13	43	54	7923-45	7924-44	1	1200
0792120365100	792LTA-1.1/8	100	16,5	48	54	7923-45	7924-44	1	1200
0792120385100	792LTA-1.1/4	100	17	51	54	7923-45	7924-44	1	1200
0792120395100	792LTA-1.5/16	100	19	54	54	7923-45	7924-44	1	1200
0792120405100	792LTA-1.3/8	100	19	54	54	7923-45	7924-44	1	1200
0792120415100	792LTA-1.7/16	100	19	54	54	7923-45	7924-44	1	1200
0792120425100	792LTA-1.1/2	100	22	60	54	7923-45	7924-44	1	1300
0792120445100	792LTA-1.5/8	100	22	63	54	7923-45	7924-44	1	1400
0792120475100	792LTA-1.13/16	100	25,5	70	54	7923-45	7924-44	1	1600
0792120485100	792LTA-1.7/8	100	27	70	54	7923-45	7924-44	1	1600
0792120495100	792LTA-2	100	27	73	54	7923-45	7924-44	1	1700
0792120515100	792LTA-2.1/8	104	30	82	54	7923-45	7924-44	1	2200
0792120525100	792LTA-2.3/16	105	32	85	54	7923-45	7924-44	1	2200
0792120535100	792LTA-2.1/4	105	33	82	54	7923-45	7924-44	1	2200
0792120545100	792LTA-2.5/16	112	33	86	54	7923-45	7924-44	1	2500

792IN-..., 792INA-...

IMPACT SOCKET 1"

- for power tools
- for inside hexagon screws
- with exchangeable blades
- special steel, phosphated
- female square drive according to DIN 3121-H 25, ISO 1174

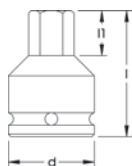

25

1"



Code	Number	l/mm	l1 mm	d mm	Locking Pin	Locking Ring	Pieces	Weight/g
0792010105100	792IN-10	82	16	54	7923-45	7924-45	1	704
0792010125100	792IN-12	82	21	54	7923-45	7924-45	1	709
0792010145100	792IN-14	82	21	54	7923-45	7924-45	1	720
0792010175100	792IN-17	89	26	54	7923-45	7924-45	1	793
0792010195100	792IN-19	89	26	54	7923-45	7924-45	1	900
0792010225100	792IN-22	89	26	54	7923-45	7924-45	1	827
0792010245100	792IN-24	89	26	54	7923-45	7924-45	1	941
0792010275100	792IN-27	95	32	54	7923-45	7924-45	1	965
0792010305100	792IN-30	100	38	54	7923-45	7924-45	1	1033
0792010325100	792IN-32	100	38	54	7923-45	7924-45	1	1060



Code	Number	l/mm	l1 mm	d mm	Locking Pin	Locking Ring	Pieces	Weight/g
0792110235100	792INA-1/2	82	19	54	7923-45	7924-45	1	716
0792110245100	792INA-9/16	82	21	54	7923-45	7924-45	1	721
0792110265100	792INA-5/8	84	24	54	7923-45	7924-45	1	725
0792110285100	792INA-3/4	89	26	54	7923-45	7924-45	1	812
0792110305100	792INA-13/16	89	26	54	7923-45	7924-45	1	826
0792110315100	792INA-7/8	95	26	54	7923-45	7924-45	1	833
0792110345100	792INA-1	95	30	54	7923-45	7924-45	1	961
0792110355100	792INA-1.1/16	95	32	54	7923-45	7924-45	1	975
0792110365100	792INA-1.1/8	95	362	54	7923-45	7924-45	1	1000
0792110375100	792INA-1.3/16	100	36	54	7923-45	7924-45	1	1034
0792110385100	792INA-1.1/4	100	38	54	7923-45	7924-45	1	1074

7921-...

IMPACT EXTENSION BAR 1"

- for power tools
- special steel, phosphated
- square according to DIN 3121, form F and H, ISO 1174



25

1"

Code	Number	l/mm	Locking Pin	Locking Ring	Pieces	Weight/g
7921001755100	7921-175	175	7923-45	7924-44	1	1497
7921002505100	7921-250	250	7923-45	7924-44	1	2000
7921003255100	7921-325	325	7923-45	7924-44	1	2200

795-1

IMPACT UNIVERSAL JOINT 1"

- ▶ for power tools
- ▶ special steel, phosphated
- ▶ square according to DIN 3121, form F and H, ISO 1174



25

1"

Code	Number	l/mm	Locking Pin	Locking Ring	Pieces	Weight/g
0795100345100	795-1	128	7923-51	7924-51	1	1766

7912-.../7922-.../7932-...

IMPACT ADAPTOR

- ▶ for power tools
- ▶ special steel, phosphated
- ▶ square according to DIN 3121, form F and H, ISO 1174



25

1"

Code	Number	Ø	□	l/mm	Locking Pin	Locking Ring	Pieces	Weight/g
7912100345100	7912-1	3/4"	1"	62	7913-37	7914-36	3	340
7922100285100	7922-3/4	1"	3/4"	75	7923-42	7924-41	1	530
7922100425100	7922-1.1/2	1"	1.1/2"	80	7923-45	7924-44	1	953
7932100345100	7932-1	1.1/2"	1"	95	7933-67	7934-67	1	1975

7923-.../7924-...

IMPACT LOCKING PIN AND RING FOR IMPACT SOCKET 1"

- ▶ for locking impact sockets and operating tools
- ▶ locking pin made of alloyed special steel
- ▶ locking ring made of rubber elastic and oil resistant material



Code	Number	l/mm	mm Ø	Pieces	Weight/g
7923000425100	7923-42	42	5,0	12	6,5
7923000455100	7923-45	45	5,0	12	7,0
7923000515100	7923-51	51	5,0	12	8,0
7924000415100	7924-41	-	41	12	4,0
7924000445100	7924-44	-	44	12	5,0
7924000455100	7924-45	-	45	12	5,5
7924000515100	7924-51	-	51	12	6,0

793-..., 793A-...

IMPACT SOCKET 1.1/2", HEXAGON

- for power tools
- special steel, phosphated
- female square drive according to DIN 3121-H 40, ISO1174
- according to DIN 3129, ISO 2725-2

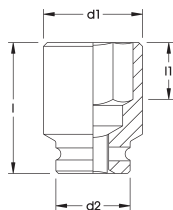

40

1.1/2"



Code	Number	l/mm	l1 mm	d1 mm	d2 mm	Locking Pin	Locking Ring	Pieces	Weight/g
0793000365100	793-36	80	19	64	86	7933-75	7934-75	1	2200
0793000415100	793-41	80	22	70	86	7933-75	7934-75	1	2400
0793000465100	793-46	80	25,5	75	86	7933-75	7934-75	1	2500
0793000505100	793-50	82	27	80	86	7933-75	7934-75	1	2300
0793000555100	793-55	89	30	86	86	7933-75	7934-75	1	2600
0793000605100	793-60	92	33	92	86	7933-75	7934-75	1	3000
0793000655100	793-65	96	35	100	86	7933-75	7934-75	1	3400
0793000705100	793-70	101	38	105	86	7933-75	7934-75	1	3700
0793000755100	793-75	105	41	109	86	7933-75	7934-75	1	3900
0793000805100	793-80	110	44	115	86	7933-75	7934-75	1	4200
0793000855100	793-85	116	47	121	86	7933-75	7934-75	1	5100
0793000905100	793-90	118	49	130	86	7933-75	7934-75	1	5200
0793000955100	793-95	118	49	135	127	7933-116	7934-116	1	9000
0793001005100	793-100	125	54	140	127	7933-116	7934-116	1	8200
0793001055100	793-105	125	54	150	127	7933-116	7934-116	1	9200
0793001105100	793-110	137	62	155	127	7933-116	7934-116	1	10800
0793001155100	793-115	137	67	160	127	7933-116	7934-116	1	12700
0793001205100	793-120	145	67	165	127	7933-116	7934-116	1	12000
0793001255100	793-125	145	67	180	127	7933-116	7934-116	1	14400



Code	Number	l/mm	l1 mm	d1 mm	d2 mm	Locking Pin	Locking Ring	Pieces	Weight/g
0793100395100	793A-1.5/16	75	19	60	86	7933-75	7934-75	1	1800
0793100405100	793A-1.3/8	75	19	60	86	7933-75	7934-75	1	1800
0793100415100	793A-1.7/16	80	19	64	86	7933-75	7934-75	1	2200
0793100425100	793A-1.1/2	80	22	64	86	7933-75	7934-75	1	2200
0793100435100	793A-1.9/16	80	22	70	86	7933-75	7934-75	1	2300
0793100445100	793A-1.5/8	80	22	70	86	7933-75	7934-75	1	2300
0793100455100	793A-1.11/16	80	25	75	86	7933-75	7934-75	1	2400
0793100465100	793A-1.3/4	80	25,5	75	86	7933-75	7934-75	1	2200
0793100475100	793A-1.13/16	80	25,5	75	86	7933-75	7934-75	1	2200
0793100485100	793A-1.7/8	82	27	80	86	7933-75	7934-75	1	2300
0793100485101	793A-1.15/16	82	27	80	86	7933-75	7934-75	1	2400
0793100495100	793A-2	82	27	80	86	7933-75	7934-75	1	2300
0793100505100	793A-2.1/16	89	30	86	86	7933-75	7934-75	1	2500
0793100515100	793A-2.1/8	89	30	86	86	7933-75	7934-75	1	2500
0793100525100	793A-2.3/16	92	32	86	86	7933-75	7934-75	1	2500
0793100535100	793A-2.1/4	92	32,5	86	86	7933-75	7934-75	1	2500
0793100545100	793A-2.5/16	92	33	92	86	7933-75	7934-75	1	2800
0793100555100	793A-2.3/8	96	35	92	86	7933-75	7934-75	1	2800
0793100565100	793A-2.7/16	96	35	96	86	7933-75	7934-75	1	3200
0793100575100	793A-2.1/2	96	35	100	86	7933-75	7934-75	1	3200
0793100585100	793A-2.9/16	96	35	100	86	7933-75	7934-75	1	3350
0793100595100	793A-2.5/8	100	38	101	86	7933-75	7934-75	1	3350
0793100595101	793A-2.11/16	101	38	101	86	7933-75	7934-75	1	3600
0793100605100	793A-2.3/4	101	38	105	86	7933-75	7934-75	1	3600
0793100615100	793A-2.13/16	105	40	109	86	7933-75	7934-75	1	3900
0793100615101	793A-2.7/8	105	41	109	86	7933-75	7934-75	1	3800
0793100625100	793A-2.15/16	105	41	109	86	7933-75	7934-75	1	3800
0793100635100	793A-3	110	44	115	86	7933-75	7934-75	1	4500
0793100635101	793A-3.1/16	110	44	115	86	7933-75	7934-75	1	4300
0793100645100	793A-3.1/8	110	44	115	86	7933-75	7934-75	1	7500
0793100645101	793A-3.3/16	110	44	115	86	7933-75	7934-75	1	8600
0793100655100	793A-3.1/4	116	47	121	86	7933-75	7934-75	1	4800

to be continued next page

Code	Number	l/mm	l1 mm	d1 mm	d2 mm	Locking Pin	Locking Ring	Pieces	Weight/g
0793100655101	793A-3.5/16	116	47	121	86	7933-75	7934-75	1	4800
0793100665100	793A-3.3/8	116	49	127	86	7933-75	7934-75	1	5400
0793100665101	793A-3.7/16	118	49	127	86	7933-75	7934-75	1	5300
0793100675100	793A-3.1/2	118	49	130	86	7933-75	7934-75	1	5600
0793100675101	793A-3.9/16	118	49	130	86	7933-75	7934-75	1	5300
0793100685100	793A-3.5/8	118	49	135	127	7933-116	7934-116	1	7800
0793100685101	793A-3.11/16	118	49	135	127	7933-116	7934-116	1	7600
0793100695100	793A-3.3/4	118	49	135	127	7933-116	7934-116	1	7600
0793100695101	793A-3.13/16	125	54	140	127	7933-116	7934-116	1	8500
0793100705100	793A-3.7/8	125	54	140	127	7933-116	7934-116	1	8500
0793100705101	793A-3.15/16	125	54	140	127	7933-116	7934-116	1	8200
0793100715100	793A-4	125	54	145	127	7933-116	7934-116	1	8800
0793100715101	793A-4.1/16	125	54	145	127	7933-116	7934-116	1	8600
0793100725100	793A-4.1/8	125	54	150	127	7933-116	7934-116	1	9500
0793100725101	793A-4.3/16	137	62	150	127	7933-116	7934-116	1	10200
0793100735100	793A-4.1/4	137	62	150	127	7933-116	7934-116	1	10000
0793100735102	793A-4.3/8	137	62	155	127	7933-116	7934-116	1	10400
0793100735101	793A-4.5/16	137	62	155	127	7933-116	7934-116	1	10600
0793100735103	793A-4.7/16	137	62	155	127	7933-116	7934-116	1	9800
0793100745100	793A-4.1/2	137	62	160	127	7933-116	7934-116	1	11200
0793100755100	793A-4.5/8	143	67	165	127	7933-116	7934-116	1	11600
0793100755101	793A-4.3/4	145	67	165	127	7933-116	7934-116	1	11400
0793100765100	793A-4.7/8	145	67	170	127	7933-116	7934-116	1	12200
0793100775100	793A-5	150	72	180	127	7933-116	7934-116	1	14400
0793100775101	793A-5.1/8	158	76	180	127	7933-116	7934-116	1	14800

793IN-..., 793INA-... IMPACT SOCKET 1.1/2"

- ▶ for power tools
- ▶ for inside hexagon screws
- ▶ with exchangeable blades
- ▶ special steel, phosphated
- ▶ female square drive according to DIN 3121-H 40, ISO 1174

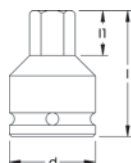

40

1.1/2"



Code	Number	l/mm	l1 mm	d mm	Locking Pin	Locking Ring	Pieces	Weight/g
0793010245100	793IN-24	120	24	86	7933-75	7934-75	1	2600
0793010275100	793IN-27	120	27	86	7933-75	7934-75	1	2600
0793010305100	793IN-30	125	30	86	7933-75	7934-75	1	2800
0793010325100	793IN-32	125	32	86	7933-75	7934-75	1	2800
0793010365100	793IN-36	145	36	86	7933-75	7934-75	1	3400
0793010415100	793IN-41	145	41	86	7933-75	7934-75	1	3520
0793010465100	793IN-46	155	46	86	7933-75	7934-75	1	4700
0793010505100	793IN-50	155	50	86	7933-75	7934-75	1	4900
0793010555100	793IN-55	155	55	86	7933-75	7934-75	1	5100



Code	Number	l/mm	l1 mm	d mm	Locking Pin	Locking Ring	Pieces	Weight/g
0793110345100	793INA-1	120	25	86	7933-75	7934-75	1	2600
0793110365100	793INA-1.1/8	120	28	86	7933-75	7934-75	1	2500
0793110385100	793INA-1.1/4	125	32	86	7933-75	7934-75	1	2600
0793110405100	793INA-1.3/8	145	35	86	7933-75	7934-75	1	3500
0793110425100	793INA-1.1/2	145	38	86	7933-75	7934-75	1	3400
0793110445100	793INA-1.5/8	145	41	86	7933-75	7934-75	1	3600
0793110465100	793INA-1.3/4	155	44	86	7933-75	7934-75	1	4700
0793110475100	793INA-1.13/16	155	46	86	7933-75	7934-75	1	4600
0793110485100	793INA-1.7/8	155	48	86	7933-75	7934-75	1	4600
0793110495100	793INA-2	155	51	86	7933-75	7934-75	1	4800
0793110515100	793INA-2.1/8	155	54	86	7933-75	7934-75	1	5000

7933-.../7934-...

IMPACT LOCKING PIN AND RING FOR IMPACT SOCKET 1.1/2"

- ▶ for locking impact sockets and operating tools
- ▶ locking pin made of alloyed special steel
- ▶ locking ring made of rubber elastic and oil resistant material



Code	Number	l/mm	mm Ø	Pieces	Weight/g
7933000675100	7933-67	67	6,0	12	15,0
7933000755100	7933-75	75	6,0	12	15,0
7933001165100	7933-116	116	6,0	12	25,0
7934000675100	7934-67	-	67	12	8,0
7934000755100	7934-75	-	75	12	8,0
7934001165100	7934-116	-	116	12	15,0

793LT-..., 793LTA-...

IMPACT SOCKET 1.1/2", EXTRA DEEP, HEXAGON

- ▶ for power tools
- ▶ special steel, phosphated
- ▶ female square drive according to DIN 3121-H 40, ISO 1174



Code	Number	l/mm	l1 mm	d1 mm	d2 mm	Locking Pin	Locking Ring	Pieces	Weight/g
0793020415100	793LT-41	140	22	70	86	7933-75	7934-75	1	4500
0793020465100	793LT-46	140	25,5	75	86	7933-75	7934-75	1	4500
0793020505100	793LT-50	140	27	80	86	7933-75	7934-75	1	4500
0793020555100	793LT-55	140	30	86	86	7933-75	7934-75	1	4000
0793020605100	793LT-60	140	33	92	86	7933-75	7934-75	1	4200
0793020655100	793LT-65	140	35	100	86	7933-75	7934-75	1	4600
0793020705100	793LT-70	140	38	105	86	7933-75	7934-75	1	5000
0793020755100	793LT-75	140	41	109	86	7933-75	7934-75	1	5300
0793020805100	793LT-80	140	44	115	86	7933-75	7934-75	1	5400
0793020855100	793LT-85	140	47	121	86	7933-75	7934-75	1	6200
0793020905100	793LT-90	140	49	130	86	7933-75	7934-75	1	6800
0793020955100	793LT-95	150	49	135	127	7933-116	7934-116	1	9900
0793021005100	793LT-100	150	54	140	127	7933-116	7934-116	1	9600
0793021055100	793LT-105	150	54	150	127	7933-116	7934-116	1	11900
0793021105100	793LT-110	160	62	155	127	7933-116	7934-116	1	12500
0793021155100	793LT-115	160	67	160	127	7933-116	7934-116	1	13200
0793021205100	793LT-120	170	67	165	127	7933-116	7934-116	1	14300

Further sizes on request



Code	Number	l/mm	l1 mm	d1 mm	d2 mm	Locking Pin	Locking Ring	Pieces	Weight/g
0793120435100	793LTA-1.9/16	140	22	70	86	7934-75	7933-75	1	4500
0793120445100	793LTA-1.5/8	140	22	70	86	7934-75	7933-75	1	4500
0793120455100	793LTA-1.11/16	140	25	75	86	7934-75	7933-75	1	4500
0793120465100	793LTA-1.3/4	140	25,5	75	86	7934-75	7933-75	1	4500
0793120475100	793LTA-1.13/16	140	25,5	75	86	7934-75	7933-75	1	4500
0793120485100	793LTA-1.7/8	140	27	80	86	7934-75	7933-75	1	4500
0793120495100	793LTA-2	140	27	80	86	7934-75	7933-75	1	4500

to be continued next page

Code	Number	l/mm	l1 mm	d1 mm	d2 mm	Locking Pin	Locking Ring	Pieces	Weight/g
0793120505100	793LTA-2.1/16	140	30	86	86	7934-75	7933-75	1	4500
0793120525100	793LTA-2.3/16	140	32	86	86	7934-75	7933-75	1	4500
0793120535100	793LTA-2.1/4	140	32,5	86	86	7934-75	7933-75	1	4500
0793120555100	793LTA-2.3/8	140	35	92	86	7934-75	7933-75	1	4600
0793120585100	793LTA-2.9/16	140	35	100	86	7934-75	7933-75	1	4900
0793120595100	793LTA-2.5/8	140	38	100	86	7934-75	7933-75	1	4900
0793120605100	793LTA-2.3/4	140	38	105	86	7934-75	7933-75	1	5000
0793120615101	793LTA-2.7/8	140	41	109	86	7934-75	7933-75	1	5600
0793120625100	793LTA-2.15/16	140	41	109	86	7934-75	7933-75	1	5600
0793120635100	793LTA-3	140	44	115	86	7934-75	7933-75	1	5900
0793120645100	793LTA-3.1/8	140	44	115	86	7934-75	7933-75	1	5900
0793120665100	793LTA-3.3/8	140	49	127	86	7934-75	7933-75	1	6600
0793120665101	793LTA-3.7/16	140	49	127	86	7934-75	7933-75	1	6600
0793120675100	793LTA-3.1/2	140	49	130	86	7934-75	7933-75	1	9900
0793120685100	793LTA-3.5/8	140	49	135	127	7934-116	7933-116	1	9900
0793120695100	793LTA-3.3/4	150	49	135	127	7934-116	7933-116	1	9900
0793120695101	793LTA-3.13/16	150	54	140	127	7934-116	7933-116	1	10700
0793120705100	793LTA-3.7/8	150	54	140	127	7934-116	7933-116	1	10700
0793120715100	793LTA-4	150	54	145	127	7934-116	7933-116	1	11200
0793120725100	793LTA-4.1/8	150	54	150	127	7934-116	7933-116	1	11900
0793120735100	793LTA-4.1/4	160	62	150	127	7934-116	7933-116	1	11900
0793120745100	793LTA-4.1/2	160	62	160	127	7934-116	7933-116	1	13200
0793120755100	793LTA-4.5/8	170	67	165	127	7934-116	7933-116	1	14300
0793120775100	793LTA-5	180	72	180	127	7934-116	7933-116	1	18200
0793120795100	793LTA-5.3/8	185	76	190	127	7934-116	7933-116	1	19000

Further sizes on request

You will find the matching automotive special sockets on page no. 443



794-..., 794A-...

IMPACT SOCKET 2.1/2", HEXAGON

- for power tools
- special steel, phosphated
- female square drive according to DIN 3121-H 63, ISO1174
- according to DIN 3129, ISO 2725-2

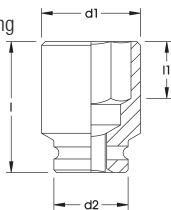

63

2.1/2"



Code	Number	l/mm	l1 mm	d1 mm	d2 mm	Locking Pin	Locking Ring	Pieces	Weight/g
0794000415100	794-41	115	21,5	104	127	7935-110	7936-114	1	7000
0794000465100	794-46	115	25,5	104	127	7935-110	7936-114	1	7000
0794000505100	794-50	115	27	104	127	7935-110	7936-114	1	7000
0794000555100	794-55	115	30	104	127	7935-110	7936-114	1	7000
0794000605100	794-60	115	35	104	127	7935-110	7936-114	1	7000
0794000655100	794-65	115	35	104	127	7935-110	7936-114	1	7000
0794000705100	794-70	115	38	104	127	7935-110	7936-114	1	7000
0794000755100	794-75	125	41	115	127	7935-110	7936-114	1	7600
0794000805100	794-80	125	44	115	127	7935-110	7936-114	1	7600
0794000855100	794-85	130	47	127	127	7935-110	7936-114	1	8000
0794000905100	794-90	132	49	135	127	7935-110	7936-114	1	8100
0794000955100	794-95	132	49	140	127	7935-110	7936-114	1	8200
0794001005100	794-100	141	54	145	127	7935-110	7936-114	1	9000
0794001055100	794-105	141	54	150	127	7935-110	7936-114	1	9600
0794001105100	794-110	150	62	160	127	7935-110	7936-114	1	11000
0794001155100	794-115	150	62	165	127	7935-110	7936-114	1	11500
0794001205100	794-120	158	67	170	127	7935-110	7936-114	1	12000
0794001255100	794-125	158	67	170	127	7935-110	7936-114	1	12000
0794001305100	794-130	174	76	180	127	7935-110	7936-114	1	14100
0794001355100	794-135	174	76	190	127	7935-110	7936-114	1	17000
0794001405100	794-140	176	79	190	127	7935-110	7936-114	1	17000
0794001455100	794-145	182	83	200	150	7935-133	7936-136	1	20000
0794001505100	794-150	190	88	210	150	7935-133	7936-136	1	22000
0794001555100	794-155	190	88	210	150	7935-133	7936-136	1	22000
0794001605100	794-160	194	91	220	150	7935-133	7936-136	1	23000

Further sizes on request



Code	Number	l/mm	l1 mm	d1 mm	d2 mm	Locking Pin	Locking Ring	Pieces	Weight/g
0794100445100	794A-1.5/8	115	21,5	104	127	7935-110	7936-114	1	7000
0794100455100	794A-1.11/16	115	25	104	127	7935-110	7936-114	1	7000
0794100465100	794A-1.3/4	115	25,5	104	127	7935-110	7936-114	1	7000
0794100475100	794A-1.13/16	115	25,5	104	127	7935-110	7936-114	1	7000
0794100485100	794A-1.7/8	115	27	104	127	7935-110	7936-114	1	7000
0794100485101	794A-1.15/16	115	27	104	127	7935-110	7936-114	1	7000
0794100495100	794A-2	115	27	104	127	7935-110	7936-114	1	7000
0794100505100	794A-2.1/16	115	30	104	127	7935-110	7936-114	1	7000
0794100515100	794A-2.1/8	115	30	104	127	7935-110	7936-114	1	7000
0794100525100	794A-2.3/16	115	32	104	127	7935-110	7936-114	1	7000
0794100535100	794A-2.1/4	115	32,5	104	127	7935-110	7936-114	1	7000
0794100545100	794A-2.5/16	115	33	104	127	7935-110	7936-114	1	7000
0794100555100	794A-2.3/8	115	35	104	127	7935-110	7936-114	1	7000
0794100565100	794A-2.7/16	115	35	104	127	7935-110	7936-114	1	7000
0794100575100	794A-2.1/2	115	35	104	127	7935-110	7936-114	1	7000
0794100585100	794A-2.9/16	115	35	104	127	7935-110	7936-114	1	7000

to be continued next page

Code	Number	l/mm ┌──┐	l1 mm	d1 mm	d2 mm	Locking Pin	Locking Ring	Pieces ☞	Weight/g ⚖
0794100595100	794A-2.5/8	115	38	104	127	7935-110	7936-114	1	7000
0794100595101	794A-2.11/16	115	38	104	127	7935-110	7936-114	1	7000
0794100605100	794A-2.3/4	115	38	104	127	7935-110	7936-114	1	7000
0794100615100	794A-2.13/16	125	40	115	127	7935-110	7936-114	1	7600
0794100615101	794A-2.7/8	125	41	115	127	7935-110	7936-114	1	7600
0794100625100	794A-2.15/16	125	41	115	127	7935-110	7936-114	1	7600
0794100635100	794A-3	125	44	115	127	7935-110	7936-114	1	7600
0794100645100	794A-3.1/8	125	44	127	127	7935-110	7936-114	1	7600
0794100655100	794A-3.1/4	130	47	127	127	7935-110	7936-114	1	8000
0794100665101	794A-3.7/16	132	49	135	127	7935-110	7936-114	1	8100
0794100675100	794A-3.1/2	132	49	135	127	7935-110	7936-114	1	8100
0794100685100	794A-3.5/8	132	49	135	127	7935-110	7936-114	1	8100
0794100695100	794A-3.3/4	132	49	140	127	7935-110	7936-114	1	8200
0794100705100	794A-3.7/8	141	54	145	127	7935-110	7936-114	1	9000
0794100715100	794A-4	141	54	150	127	7935-110	7936-114	1	9600
0794100715101	794A-4.1/16	141	54	150	127	7935-110	7936-114	1	9600
0794100725100	794A-4.1/8	141	54	150	127	7935-110	7936-114	1	9600
0794100735100	794A-4.1/4	150	62	155	127	7935-110	7936-114	1	10500
0794100745100	794A-4.1/2	150	62	165	127	7935-110	7936-114	1	11300
0794100755100	794A-4.5/8	158	67	170	127	7935-110	7936-114	1	12000
0794100755101	794A-4.3/4	158	67	170	127	7935-110	7936-114	1	12000
0794100765100	794A-4.7/8	158	67	170	127	7935-110	7936-114	1	12000
0794100775100	794A-5	165	72	180	127	7935-110	7936-114	1	14100
0794100775101	794A-5.1/8	174	76	180	127	7935-110	7936-114	1	14100
0794100785100	794A-5.1/4	174	76	190	127	7935-110	7936-114	1	17000
0794100795100	794A-5.3/8	174	76	190	127	7935-110	7936-114	1	17000
0794100805100	794A-5.5/8	182	83	200	150	7935-133	7936-136	1	20000
0794100815100	794A-5.3/4	182	83	200	150	7935-133	7936-136	1	20000

Further sizes on request

7935-.../7936-...
IMPACT LOCKING PIN AND RING FOR IMPACT SOCKETS 2.1/2"

- for locking impact sockets and operating tools
- locking pin made of alloyed special steel
- locking ring made of rubber elastic and oil resistant material



Code	Number	l/mm ┌──┐	mm Ø	Pieces ☞	Weight/g ⚖
7935001105100	7935-110	110	8,0	12	30
7935001335100	7935-133	133	8,0	12	50
7936001145100	7936-114	-	114	12	45
7936001365100	7936-136	-	136	12	50

4100-IS...

SCREWDRIVER BIT 1/4"

- for plain slotted screws
- ELORA-Chrome-Molybdenum-Vanadium 73MoV5-2 / 1.2381
- male hexagon according to DIN 3126 E 6,3, DIN ISO 1173
- according to DIN ISO 2351-1



6,3

1/4"



Code	Number	l/mm	Pieces	Weight/g
4100005045200	4100-IS 0,5x4	50	12	8
4100008045200	4100-IS 0,8x4	50	12	9
4100016085200	4100-IS 1,6x8	50	12	15
4100016095200	4100-IS 1,6x9	50	12	16
4100016115200	4100-IS 1,6x11	50	12	20
4100020125200	4100-IS 2x12	50	12	22

4120-PH...

SCREWDRIVER BIT 1/4"

- for cross slotted screws PH
- ELORA-Chrome-Molybdenum-Vanadium 73MoV5-2 / 1.2381
- male hexagon according to DIN 3126 E 6,3, DIN ISO 1173
- according to DIN ISO 2351-2, tip according to DIN ISO 8764-1 PH



6,3

1/4"



Code	Number	l/mm	Pieces	Weight/g
412000005200	4120-PH 0	50	12	7,6
412000015200	4120-PH 1	50	12	8,8
412000025200	4120-PH 2	50	12	10,0
412000035200	4120-PH 3	50	12	12,0

4130-PZ...

SCREWDRIVER BIT 1/4"

- for cross slotted screws PZ
- ELORA-Chrome-Molybdenum-Vanadium 73MoV5-2 / 1.2381
- male hexagon according to DIN 3126 E 6,3, DIN ISO 1173
- according to DIN ISO 2351-2, tip according to DIN ISO 8764-1 PZ



6,3

1/4"



Code	Number	l/mm	Pieces	Weight/g
413000005200	4130-PZ 0	50	12	7,6
413000015200	4130-PZ 1	50	12	8,8
413000025200	4130-PZ 2	50	12	10,8
413000035200	4130-PZ 3	50	12	12,4
413000045200	4130-PZ 4	50	12	18,0

4110-IN

SCREWDRIVER BIT 1/4"

- for inside hexagon screws
- ELORA-Chrome-Molybdenum-Vanadium 73MoV5-2 / 1.2381
- male hexagon according to DIN 3126 E 6,3, DIN ISO 1173
- according to DIN ISO 2351-3



6,3

1/4"



Code	Number	l/mm	Pieces	Weight/g
4110000305200	4110-IN 3	50	12	8,4
4110000405200	4110-IN 4	50	12	10,8
4110000505200	4110-IN 5	50	12	11,2
4110000605200	4110-IN 6	50	12	12,8
4110000705200	4110-IN 7	50	12	15,2
4110000805200	4110-IN 8	50	12	16,5
4110001005200	4110-IN 10	50	12	22,4

4160-TX...

SCREWDRIVER BIT 1/4"

- for inside TORX® screws
- ELORA-Chrome-Molybdenum-Vanadium 73MoV5-2 / 1.2381
- male hexagon according to DIN 3126 E 6,3, DIN ISO 1173
- TORX® = reg. trademark of Acument Intellectual Properties, LLC. USA



6,3

1/4"



Code	Number	mm	l/mm	Pieces	Weight/g
416000105200	4160-TX10	2,74	70	6	10,4
416000155200	4160-TX15	3,27	70	6	10,4
416000205200	4160-TX20	3,86	70	6	11,6
416000255200	4160-TX25	4,43	70	6	14,8
416000275200	4160-TX27	4,99	70	6	13,2
416000305200	4160-TX30	5,52	70	6	15,2
416000405200	4160-TX40	6,65	70	6	17,6

3000-IS...

SCREWDRIVER BIT 1/4"

- for plain slotted screws
- ELORA-Chrome-Molybdenum-Vanadium 73MoV5-2 / 1.2381
- male hexagon according to DIN 3126 C 6,3, DIN ISO 1173
- according to DIN ISO 2351-1



6,3

1/4"



Code	Number	l/mm	Pieces	Weight/g
3000005035200	3000-IS 0,5x 3	39	12	5
3000005045200	3000-IS 0,5x 4	39	12	5,3
3000006355200	3000-IS 0,6x3,5	39	12	6
3000006045200	3000-IS 0,6x4	39	12	5,5
3000006455200	3000-IS 0,6x4,5	39	12	7
3000008045200	3000-IS 0,8x4	39	12	7
3000008555200	3000-IS 0,8x5,5	39	12	7
3000010555200	3000-IS 1,0x5,5	39	12	7,5
3000012655200	3000-IS 1,2x6,5	39	12	11,6
3000012085200	3000-IS 1,2x8	39	12	8,7
3000016085200	3000-IS 1,6x8	39	12	11,6
3000016105200	3000-IS 1,6x10	39	12	15,6

3020-PH...

SCREWDRIVER BIT 1/4"

- for cross slotted screws PH
- ELORA-Chrome-Molybdenum-Vanadium 73MoV5-2 / 1.2381
- male hexagon according to DIN 3126 C 6,3, DIN ISO 1173
- according to ISO 2351-2, tip according to DIN ISO 8764-1 PH



6,3

1/4"



Code	Number	l/mm	Pieces	Weight/g
3020001255200	3020-PH 1x25	25	12	4,8
3020002255200	3020-PH 2x25	25	12	5,2
3020002325200	3020-PH 2x32	32	12	6,9
3020002505200	3020-PH 2x50	50	12	11,6
3020003255200	3020-PH 3x25	25	12	5,2
3020003325200	3020-PH 3x32	32	12	7,2

3021-PZ...

SCREWDRIVER BIT 1/4"

- for cross slotted screws PZ
- ELORA-Chrome-Molybdenum-Vanadium 73MoV5-2 / 1.2381
- male hexagon according to DIN 3126 C 6,3, ISO 1173
- according to ISO 2351-2, tip according to DIN ISO 8764-1 PZ



6,3

1/4"



Code	Number	l/mm	Pieces	Weight/g
3021001255200	3021-PZ 1x25	25	12	5,5
3021002255200	3021-PZ 2x25	25	12	5,6
3021002505200	3021-PZ 2x50	50	12	12
3021003255200	3021-PZ 3x25	25	12	5,6
3021003325200	3021-PZ 3x32	32	12	7,4

3010-IN...

SCREWDRIVER BIT 1/4"

- for inside hexagon screws
- ELORA-Chrome-Molybdenum-Vanadium 73MoV5-2 / 1.2381
- male hexagon according to DIN 3126 C 6,3, ISO 1173
- according to DIN ISO 2351-3



6,3

1/4"



Code	Number	l/mm	Pieces	Weight/g
3010000305200	3010-IN 3	25	12	5
3010000405200	3010-IN 4	25	12	5
3010000505200	3010-IN 5	25	12	5,4
3010000605200	3010-IN 6	25	12	6,0
3010001005200	3010-IN 10	25	12	11,2

3050-TX...

SCREWDRIVER BIT 1/4"

- for inside TORX® screws
- ELORA-Chrome-Molybdenum-Vanadium 73MoV5-2 / 1.2381
- male hexagon according to DIN 3126 C 6,3, ISO 1173
- TORX® = reg. trademark of Acument Intellectual Properties, LLC. USA



6,3

1/4"



Code	Number	★ mm	l/mm	Pieces	Weight/g
3050000065200	3050-TX 6	1,69	25	12	4,2
3050000075200	3050-TX 7	1,99	25	12	4,3
3050000085200	3050-TX 8	2,31	25	12	4,4
3050000095200	3050-TX 9	2,5	25	12	4,4
3050000105200	3050-TX 10	2,74	25	12	4,5
3050000155200	3050-TX 15	3,27	25	12	4,6
3050000205200	3050-TX 20	3,86	25	12	5
3050000255200	3050-TX 25	4,43	25	12	5,2
3050000275200	3050-TX 27	4,99	25	12	5,4
3050000305200	3050-TX 30	5,52	25	12	5,6
3050000405200	3050-TX 40	6,65	25	12	6,4

3070-TTX...

SCREWDRIVER BIT 1/4"

- for inside-TORX® safety screws
- ELORA-Chrome-Molybdenum-Vanadium 73MoV5-2 / 1.2381
- male hexagon according to DIN 3126 C 6,3, ISO 1173
- TORX® = reg. trademark of Acument Intellectual Properties, LLC. USA



6,3

1/4"



Code	Number	l/mm	★ mm	Pieces	Weight/g
3070000105200	3070-TTX 10	26	2,74	12	4,4
3070000155200	3070-TTX 15	26	3,27	12	4,6
3070000205200	3070-TTX 20	26	3,86	12	4,6
3070000255200	3070-TTX 25	26	4,43	12	5
3070000275200	3070-TTX 27	26	4,99	12	5,4
3070000305200	3070-TTX 30	26	5,52	12	5,4
3070000405200	3070-TTX 40	26	6,65	12	6

3050-IPR...

SCREWDRIVER BIT 1/4"

- for TORX Plus® IPR-screws
- ELORA-Chrom-Molybdän-Vanadium 73MoV5-2 / 1.2381
- male hexagon according to DIN 3126 C 6,3, ISO 1173
- TORX® = reg. trademark of Acument Intellectual Properties, LLC. USA



6,3

1/4"

Code	Number	l/mm	Pieces	Weight/g
3050000105300	3050-IPR 10	25	12	4,5
3050000155300	3050-IPR 15	25	12	4,6
3050000205300	3050-IPR 20	25	12	5,0
3050000255300	3050-IPR 25	25	12	5,2
3050000275300	3050-IPR 27	25	12	5,4
3050000305300	3050-IPR 30	25	12	5,6
3050000405300	3050-IPR 40	25	12	6,4

3030-XZN...

SCREWDRIVER BIT 1/4"

- ▶ for inside multi-point B&S and XZN screws
- ▶ ELORA-Chrome-Molybdenum-Vanadium 73MoV5-2 / 1.2381
- ▶ male hexagon according to DIN 3126 C 6,3, ISO 1173

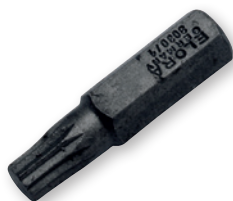

6,3

1/4"



Code	Number	l/mm	Pieces	Weight/g
3030000055200	3030-XZN M5	25	12	5,2
3030000065200	3030-XZN M6	25	12	5,6

3040-RIB...

SCREWDRIVER BIT 1/4"

- ▶ for RIBE®-CV-screws
- ▶ ELORA-Chrome-Molybdenum-Vanadium 73MoV5-2 / 1.2381
- ▶ male hexagon drive according to DIN 3126 C 6,3, ISO 1173
- ▶ RIBE® = reg. trademark of Richard Bergner GmbH & Co KG, Schwabach



6,3

1/4"



Code	Number	l/mm	Pieces	Weight/g
3040000055200	3040-RIB M5	32	12	5,0
3040000065200	3040-RIB M6	32	12	6,8
3040000085200	3040-RIB M8	32	12	10,0
3040000105200	3040-RIB M10	32	12	13,2

3080-...

DOUBLE FUNCTION SCREWDRIVER BIT 1/4"

- ▶ cross-slotted head screws PH
- ▶ 1/4" hexagonal shank
- ▶ ELORA-Chrome-Molybdenum-Vanadium 73MoV5-2/ 1.2381



6,3

1/4"



Code	Number	l/mm	Pieces	Weight/g
3080010015260	3080-PH 1	0,6x4,5	12	13
3080010025260	3080-PH 2	0,8x5,5	12	14
3080010035260	3080-PH 3	1,0x7,0	12	16

3100-IS...

SCREWDRIVER BIT 5/16"

- ▶ for plain slotted screws
- ▶ ELORA-Chrome-Molybdenum-Vanadium 73MoV5-2 / 1.2381
- ▶ male hexagon drive according to DIN 3126 C 8, DIN ISO 1173
- ▶ according to DIN ISO 2351-1



8

5/16"



Code	Number	l/mm	Pieces	Weight/g
3100008555200	3100-IS 0,8x5,5	41	12	9,6
3100010555200	3100-IS 1x5,5	41	12	10,4
3100012655200	3100-IS 1,2x6,5	41	12	12,4
3100012805200	3100-IS 1,2x8,0	41	12	16
3100016805200	3100-IS 1,6x8,0	41	12	16
3100020125200	3100-IS 2,0x12	41	12	24
3100025145200	3100-IS 2,5x14	41	12	30

3120-PH...

SCREWDRIVER BIT 5/16"

- ▶ for cross slotted screws PH
- ▶ ELORA-Chrome-Molybdenum-Vanadium 73MoV5-2 / 1.2381
- ▶ male hexagon drive according to DIN 3126 C 8, DIN ISO 1173
- ▶ according to DIN ISO 2351-2, tip according to DIN ISO 8764-1 PH



8

5/16"



Code	Number	l/mm	Pieces	Weight/g
3120001325200	3120-PH 1x32	32	12	10
3120002325200	3120-PH 2x32	32	12	10
3120003325200	3120-PH 3x32	32	12	11
3120004325200	3120-PH 4x32	32	12	11,5
3120004385200	3120-PH 4x38	38	12	17

3121-PZ...

SCREWDRIVER BIT 5/16"

- ▶ for cross slotted screws PZ
- ▶ ELORA-Chrome-Molybdenum-Vanadium 73MoV5-2 / 1.2381
- ▶ male hexagon according to DIN 3126 C 8, DIN ISO 1173
- ▶ according to DIN ISO 2351-2, tip according to DIN ISO 8764-1 PZ



8

5/16"



Code	Number	l/mm	Pieces	Weight/g
3121000015200	3121-PZ 1	32	12	10
3121000025200	3121-PZ 2	32	12	10
3121000035200	3121-PZ 3	32	12	10,4
3121000045200	3121-PZ 4	32	12	13,2

3110-IN...

SCREWDRIVER BIT 5/16"

- ▶ for inside hexagon screws
- ▶ ELORA-Chrome-Molybdenum-Vanadium 73MoV5-2 / 1.2381
- ▶ male hexagon drive according to DIN 3126 C 8, DIN ISO 1173
- ▶ according to DIN ISO 2351-3



8

5/16"



Code	Number	l/mm	Pieces	Weight/g
3110000035200	3110-IN 3	30	12	7,6
3110000045200	3110-IN 4	30	12	9,6
3110000055200	3110-IN 5	30	12	8,9
3110000065200	3110-IN 6	30	12	10,4
3110000085200	3110-IN 8	30	12	12
3110000105200	3110-IN 10	30	12	14,4

3150-TX...

SCREWDRIVER BIT 5/16"

- ▶ for inside TORX® screws
- ▶ ELORA-Chrome-Molybdenum-Vanadium 73MoV5-2 / 1.2381
- ▶ male hexagon drive according to DIN 3126 C 8, DIN ISO 1173
- ▶ TORX® = reg. trademark of Acument Intellectual Properties, LLC. USA



8

5/16"



Code	Number	mm	l/mm	Pieces	Weight/g
3150000255200	3150-TX 25	4,43	35	12	10,2
3150000275200	3150-TX 27	4,99	35	12	10,4
3150000305200	3150-TX 30	5,52	35	12	10,8
3150000405200	3150-TX 40	6,65	35	12	11,8
3150000455200	3150-TX 45	7,82	35	12	12,9
3150000505200	3150-TX 50	8,83	35	12	14,4
3150000555200	3150-TX 55	11,22	35	12	20,4

3130-XZN...

SCREWDRIVER BIT 5/16"

- ▶ for inside multi-point B&S and XZN screws
- ▶ ELORA-Chrome-Molybdenum-Vanadium 73MoV5-2 / 1.2381
- ▶ male hexagon drive according to DIN 3126 C 8, DIN ISO 1173



8

5/16"



Code	Number	l/mm	Pieces	Weight/g
3130000055200	3130-XZN 5	28	12	8,4
3130000065200	3130-XZN 6	28	12	8,4
3130000085200	3130-XZN 8	28	12	9,6
3130000105200	3130-XZN 10	32	12	10,4
3130000125200	3130-XZN 12	36	12	22
3130000145200	3130-XZN 14	36	12	31

3170-TTX...

SCREWDRIVER BIT 5/16"

- ▶ for inside-TORX® safety screws
- ▶ ELORA Chrome-Molybdenum-Vanadium 73MoV5-2 / 1.2381
- ▶ male hexagon drive according to DIN 3126 C 8, DIN ISO 1173
- ▶ TORX® = reg. trademark of Acument Intellectual Properties, LLC. USA



8

5/16"



Code	Number	mm	l/mm	Pieces	Weight/g
3170000255200	3170-TTX 25	4,43	35	12	10
3170000275200	3170-TTX 27	4,99	35	12	10
3170000305200	3170-TTX 30	5,52	35	12	11
3170000505200	3170-TTX 50	8,83	35	12	14
3170000555200	3170-TTX 55	11,22	35	12	20

3090

BIT RATCHET, STRAIGHT

- ▶ bit lock with permanent magnet
- ▶ reversible
- ▶ female hexagon drive according to DIN 3126 D 6,3 (1/4") and DIN 3126 D 8 (5/16")



6,3

8



1/4"

5/16"

Code	Number	l/mm	Pieces	Weight/g
3090000002000	3090	138	6	105

3090G

BIT RATCHET, CRANKED

- ▶ bit lock with permanent magnet
- ▶ reversible
- ▶ female hexagon drive according to DIN 3126 D 6,3 (1/4") and DIN 3126 D 8 (5/16")



6,3

8



1/4"

5/16"

Code	Number	l/mm	Pieces	Weight/g
3090000102000	3090G	140	6	105

3415

HAND BIT HOLDER 1/4"

- ▶ bit lock with permanent magnet
- ▶ nonslip QUATROLIT®-2C-handle
- ▶ with suspension hole
- ▶ ELORA-Chrome-Vanadium 31CrV3 / 1.2208
- ▶ female hexagon drive according to DIN 3126 D 6,3 DIN ISO 1173



Code	Number	l/mm	⊙	Pieces	Weight/g
341500000000	3415	180	1/4"	6	130

3300-...

ADAPTOR FOR SCREWDRIVER BITS

- ▶ for power tools
- ▶ bit lock with spring clip
- ▶ gunmetal finished
- ▶ ELORA-Chrome-Vanadium Steel 31CrV3 / 1.2208
- ▶ female hexagon drive according to DIN 3126 D 6,3 respectively DIN 3126 D 8; DIN ISO 1173
- ▶ female square drive according to DIN 3121 Form G
- ▶ according to DIN 7427 Form A



Code	Number	⊙	⊙	l/mm	Pieces	Weight/g
3300113132000	3300-1/4x1/4	1/4"	1/4"	25	6	18
3300119132000	3300-3/8x1/4	3/8"	1/4"	30	6	40,8
3300119172000	3300-3/8x5/16	3/8"	5/16"	30	6	41
3300123132000	3300-1/2x1/4	1/2"	1/4"	35	6	80
3300123172000	3300-1/2x5/16	1/2"	5/16"	35	6	64

4150-...

BITHOLDER 1/4"

- ▶ bit lock with permanent magnet resp. spring clips
- ▶ with stainless steel sleeve, diameter 9,5 mm
- ▶ female hexagon drive according to DIN 3126 D 6,3
- ▶ male hexagon drive according to DIN 3126 E 6,3 DIN ISO 1173
- ▶ according to DIN 7427 Form D

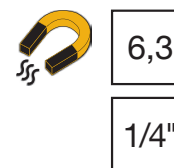

Code	Number	l/mm	⊙	⊙	Pieces	Weight/g
4150000505200	4150-50	50	1/4"	1/4" with spring clip and magnet	6	26
4150001005200	4150-100	100	1/4"	1/4" with spring clip and magnet	6	39

3428

BITHOLDER 1/4"

- ▶ bit lock with permanent magnet and quick clamping system
- ▶ quick locker and ejection system
- ▶ female hexagon drive according to DIN 3126 D 6,3
- ▶ male hexagon drive according to DIN 3126 E 6,3, DIN ISO 1173

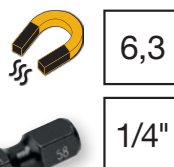

Code	Number	l/mm	⊙	Pieces	Weight/g
3428000000000	3428	51	1/4"	6	24

3429

BITHOLDER 1/4"

- ▶ with strong permanent magnet for holding the bit
- ▶ bit lock due to quick clamping system and ejection function
- ▶ female hexagon drive according to DIN 3126 D 6,3 and F 6,3
- ▶ male hexagon drive according to DIN 3126 E 6,3, DIN ISO 1173

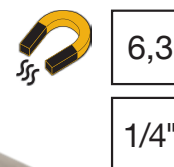

Code	Number	l/mm	⊙	Pieces	Weight/g
3429000000000	3429	60	1/4"	6	27

3452ST

BIT-BOX, STAINLESS 1/4"

- 19 pcs.
- bit holder ELORA-No. 3428 with quick clamping system and male hexagon drive according to DIN 3126 E 6,3
- bits made of stainless steel X46Cr13 / 1.4034, without galvanic surface treatment
- 18 bits with male hexagon drive according to DIN 3126 C 6,3

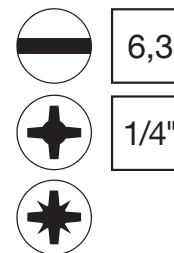

Code	Number	Contents	Pieces	Weight/g
3452500008000	3452ST	1 Magnetic quick action bit holder ELORA-No.3428 2 piece each plain slotted Screwdriver Bits 0,8x5,5, 1,0x5,5, 1,2x5,5 mm 2 piece each Philips Screwdriver Bits PH1, PH2, PH3 2 piece each Pozidriv Screwdriver Bits PZ1, PZ2, PZ3	1	180

3451-S9

BIT-BOX 1/4"

- 9 pcs.
- in black plastic box with transparent cover
- magnetic bit holder ELORA-No. 4150-50, with male hexagonal drive according to DIN 3126 E 6,3
- bits made of ELORA-Chrome-Molybdenum-Vanadium 73MoV5-2 / 1.2381
- 8 bits with male hexagon drive according to DIN 3126 C 6,3

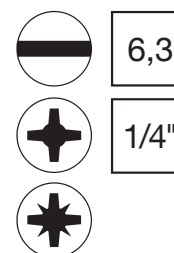

Code	Number	Contents	Pieces	Weight/g
3451500000000	3451-S9	1 Magnetic bit holder ELORA-No.4150-50 1 piece each plain slotted Screwdriver Bit 4,5x0,6, 6,5x1,2 mm 1 piece each Philips Screwdriver Bit PH1, 2x PH2 1 piece each Pozidriv Screwdriver Bit PZ1, 2x PZ2	1	108

3453-S11

BIT-BOX 1/4"

- 11 pcs.
- in black yellow plastic box with belt clip and suspension hole
- magnetic bit holder ELORA-No. 4150-50, with male hexagonal drive according to DIN 3126 E 6,3
- bits made of ELORA-Chrome-Molybdenum-Vanadium 73MoV5-2 / 1.2381
- 10 bits with male hexagon drive according to DIN 3126 C 6,3
- TORX® = reg. trademark of Acument Intellectual Properties, LLC. USA

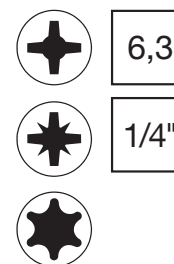

Code	Number	Contents	Pieces	Weight/g
3453000000000	3453-S11	1 Magnetic bit holder ELORA-No. 4150-50 1 piece each Philips Screwdriver Bit PH1, PH2 1 piece each Pozidriv Screwdriver Bit PZ1, PZ2 1 piece each TORX® Screwdriver-Bit TX10, TX15, TX20, TX25, TX30, TX40	1	125

3436-S36

BIT-BOX 1/4"

- 36 pcs.
- in black yellow plastic box with belt clip and suspension hole
- magnetic bit holder ELORA-No. 4150-50, with male hexagonal drive according to DIN 3126 E 6,3
- bits made of ELORA Chrome-Molybdenum-Vanadium 73MoV5-2 / 1.2381
- 35 bits with male hexagon drive according to DIN 3126 C 6,3
- TORX® = reg. trademark of Acument Intellectual Properties, LLC. USA

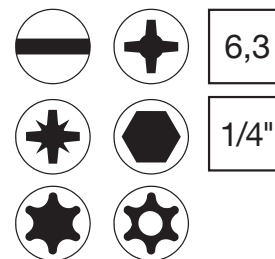

Code	Number	Contents	Pieces	Weight/g
3436000000000	3436-S36	1 Magnetic bit holder ELORA-No. 4150-50 1 piece each each plain slotted Screwdriver Bit 4,5, 5,5, 6,5 mm Philips Screwdriver Bits 2x PH1, 3x PH2, 2x PH3 Pozi driv Screwdriver Bits 2x PZ1, 3x PZ2, 2x PZ3 1 piece each Inside hexagon Screwdriver Bit IN2, IN 2,5, IN3, IN4, IN5, IN5,5, IN6 1 piece each TORX®-Screwdriver Bit TX10, TX15, TX20, TX25, TX27, TX30, TX40 1 piece each TORX®-Screwdriver Bit TTX20, TTX25, TTX30 TTX40	1	340

3400

HAND OPERATED IMPACT DRIVER 1/2"

- for loosening tight screws with help of a hammer
- reversible with anti-slip plastic grip
- male square drive according to DIN 3120-A 12,5, ISO 1174, with ball locking device

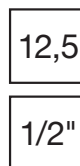

Code	Number	l/mm	Pieces	Weight/g
3400000000000	3400	150	1	750

3401-S12

HAND OPERATED IMPACT DRIVER SET

- 12 pcs.
- in black metal case with plastic inlet
- for loosening tight screws with help of a hammer
- reversible with anti-slip plastic grip
- male square drive according to DIN 3120-A 12,5, ISO 1174, with locking device



Code	Number	Contents	Pieces	Weight/g
3401500120000	3401-S12	1 Hand Operated Impact Driver ELORA-No. 3400 1 Adaptor 3300-1/2x5/16 1 piece each Screwdriver Insert Bit, Plain Slot, 3100-IS 1,0x5,5, 1,2x6,5, 1,6x8,0, 2,0x12,0 mm 1 piece each Screwdriver Insert Bit, cross slot, 3120-PH 2x32, PH 3x32, PH 4x32 1 piece each Screwdriver Insert Bit, inside hexagon 3110-IN 6, IN 8, IN 10 mm	1	1385





Torque wrenches

Clicking Torque Wrenches _____	Page 236
Clicking Torque Screwdrivers _____	Page 240
Clicking Torque Wrenches and insert tools _____	Page 241
Indicating Torque Wrenches _____	Page 247
Power Multipliers _____	Page 249



ELORA, 5 letters that represent us:
E and **RA** stand for **Erich Rauch**, founder of ELORA. **LO** for **Lüttringhausen**.
Since **Ü** cannot be translated into English, Erich Rauch decided in 1924 on **ELORA**.

Why is controlled fastener tightening important?

Anyone involved in modern engineering will already know how important controlled tightening is. To ensure safe, dependable threaded joints, clearly defined tightening forces are essential, irrespective of whether the forces to be applied are large or small (such as is the case with light-weight materials with a low yield point).

The decision on the correct tightening force is subject to a number of factors. These include the fastener's thread pitch, the friction in the thread and the material under the nut or screw head. Once all the relevant factors have been taken into account, this results in the required tightening force that will ensure the bolted joint will not become loose even under dynamic loading. By the same token, this tightening force must not be too high as this can also cause the bolted joint to fail.

What exactly is torque?

Torque is a physical quantity in mechanics. The international unit of measure for moment of force, or torque, is the newton metre, Nm. Torque is defined as a force acting perpendicular to a moment arm.

$$M = F \cdot r$$

A torque wrench is constructed in such a way that it is operated by applying force to the handle. If the lever ratio is changed in any way, this will result in incorrect torque values – a key issue that is referred to in the documentation for all ELORA torque wrenches.

Screw tightening using torque and tightening angle

In many cases, it is sufficient to tighten a bolt or screw to a certain defined torque. To ensure the application of accurate, defined tightening forces, special expanding screws are used. Screws of this type may only be used once. In the first stage, they are tightened to a defined torque and then a specified tightening angle is applied to tighten the screw beyond the elastic limit of the bolt.

This enables a much more accurate tightening force to be achieved.

In addition to an ELORA torque wrench, angle controlled tightening requires a mechanical angle measuring instrument (ELORA no. 2184...).

Conformity Test and Calibration

The DIN EN ISO 6789:2017 has been divided into 2 parts. Part 1 determines requirements for construction and manufacturing, including contents of the declaration of conformity. Part 2, above all, determines the requirements for traceable calibration certificates and includes a procedure to calculate measurement uncertainties.

The ELORA Torque Wrench Calibration Laboratory is covering both parts. Each torque wrench will be delivered with a declaration of conformance, because for most users, this is absolutely sufficient.

In case of not being differently mentioned within inspection equipment monitoring, the DIN EN 6789:2017 specifies a working life of 12 months or 5000 load changes being the interval for conformity test or calibration. The interval starts with the first use of the torque tool.

05



2179-...

TORQUE WRENCH, WITH VERNIER SCALE

- for controlled torque application from 10 – 335 Nm
- main unit Nm with Nonius, secondary unit ft.lb.
- safe locking of the adjusted torque value by securing button at the handle end
- ELORA-No. 2179-S: exchanging the locking knob through the safety cap, the torque can be fixed tamper-resistant
- for clockwise fixing
- with robust, matt steel tube
- fine tooth ratchet, smallest possible swivel angle 8°
- very noticeable and hearable ("click") signal
- nonslip QUATROLIT®-2C-handle
- according to EN ISO 6789:2017 Part 1, Typ II Class A
- with traceable declaration of conformance
- tripping accuracy +/-3%

Product features

- Broad range of applications
- High degree of availability
- Highly economical
- Very service-friendly
- Complies with DIN EN ISO 6789:2017

10	12,5
3/8"	1/2"



2179-S safety cap



Code	Number	□	Head	Measuring range Nm	Graduation Nm	Measuring range ft.lb.	Graduation ft.lb.	l/mm	Pieces	Weight/g
2179000601000	2179-60	3/8"	Reversible ratchet	10-60	0,25	9-45	4	390	1	1250
2179001251000	2179-125	1/2"	Reversible ratchet	25-125	0,25	20-90	5	440	1	1230
2179002001000	2179-200	1/2"	Reversible ratchet	40-200	0,5	30-150	10	460	1	1366
2179003351000	2179-335	1/2"	Reversible ratchet	65-335	0,75	50-250	10	525	1	1465
2179000001000	2179-S			Safety cap for model 2179 2070 2080 2034					1	10

High availability and economy

ELORA has succeeded in achieving the ambitious objective of increasing the periods of effective use between readjustments to considerably more than 5000 "clicks" with no errors or loss in accuracy. Extensive long-term tests have demonstrated convincingly that the torque wrenches managed 8000 "clicks" with no problems.

ELORA – Declaration of Conformity

Each hand operated torque tool leaves our works with a declaration of conformance according to DIN EN ISO 6789:2017 Part 1.

ELORA services and controls your torque wrenches quickly and cost-saving. On demand also according to DIN EN ISO 6789:2017 part 2.

Wide range of applications

The torque wrench must work accurately even when subjected to extreme fluctuations in temperature and in environments in which dust and moisture are commonly encountered. This is why ELORA torque wrenches are intensively tested under all conceivable operating conditions at ELORA's own calibration laboratory. The ELORA torque wrenches have all passed the tests with flying colours.

A particularly important feature is the temperature from -15 to +40°C. The design of the tool, the torquing mechanism and the choice of components and materials are further evidence of ELORA's innovative approach to professional products enabling efficient working.

This is how you can fix the torque tamper-resistant



Adjust release torque



Fix with locking knob



Untwist locking knob



Tamper-resistant closing by safety cap



No nondestructive removal of the safety cap

2185-...

TORQUE WRENCH 1/2"

- for controlled torque application from 20 - 350 Nm / 15 - 250 ft.-lb.
- dual measurement scale for Nm and ft.lb.
- scale slider and window with magnifier for quick setting of the target torque value
- locking screw for safe locking of the set torque value
- for clockwise fixing
- with robust, matt steel tube
- all models with fine tooth, reversible ratchet
- very noticeable and audible ("click") signal
- according to DIN EN ISO 6789:2017 Part 1, Typ II Class A
- with traceable declaration of conformance
- tripping accuracy +/- 4%

12,5

1/2"



Code	Number	□	Head	Measuring range Nm	Measuring range ft.lb.	l/mm	Pieces	Weight/g
2185001002000	2185-100	1/2"	Reversible ratchet	20-100	15-80	450	1	1473
2185002002000	2185-200	1/2"	Reversible ratchet	40-200	30-150	450	1	1432
2185003502000	2185-350	1/2"	Reversible ratchet	60-350	42-250	590	1	1705

2130 - 2160

TORQUE WRENCH

- for controlled torque application from 2,5 - 2000 Nm
- quad measurement scale for Nm, kgm, in-lb and ft-lb
- click type torque wrench with very noticeable and audible ("click") signal
- bi-directional fixing by turning the torque wrench
- extra solid, matt-chrome plated steel construction
- adjustable and safe lockable by crank and the top end of the handle
- according to DIN EN ISO 6789:2017 Part 1, Typ II Class A
- with traceable declaration of conformance
- tripping accuracy +/- 4%

10

12,5

20

25

3/8"

1/2"

3/4"

1"



Code	Number	□	Measuring range Nm	Graduation Nm	Measuring range kgm	Graduation kgm	Measuring range in.lb.	Graduation in.lb.	Measuring range ft.lb.	Graduation ft.lb.	l/mm	Pieces	Weight/g
2130000112000	2130-11	3/8"	2,5-11	0,5	0,3-1,2	0,2	20-100	10	2-8	1	338	1	672
2130000332000	2130-33	3/8"	7-33	1	0,7-3,4	0,1	60-300	10	5-24	1	425	1	1000
2130000682000	2130-68	3/8"	12-68	2	1,2-7	0,2	100-600	20	10-50	2	500	1	1000
2140000682000	2140-68	1/2"	14-68	2	1,4-7	0,2	125-600	20	10-50	2	500	1	1114
2140001352000	2140-135	1/2"	30-135	5	3-14	1	250-1200	50	40-160	2	556	1	1974
2140002252000	2140-225	1/2"	50-225	10	5-23	1	400-2000	50	40-160	5	600	1	2000
2140003302000	2140-330	1/2"	70-330	10	7-35	1	600-3000	100	50-250	10	805	1	3850
2150008102000	2150-810	3/4"	200-800	20	22-82	2	1800-7200	200	140-600	20	1070	1	9000
2160009402000	2160-940	1"	200-1000	20	22-100	2	1800-8850	200	140-740	20	1400	1	13800
2160020002000	2160-2000	1"	500-2000	50	50-200	5	4500-17500	500	350-1500	50	1410	1	18000

You will find VDE Torque Wrenches on page 321.



2070-...

TORQUE WRENCH 3/4" WITH VERNIER SCALE

- for controlled torque application from 100 - 1000 Nm
- main measurement unit for Nm with vernier scale, auxiliary measurement unit for ft.-lb.
- Safe locking of the adjusted torque value by securing button at the handle end
- ELORA-No. 2179-S: exchanging the locking knob through the safety cap, the torque can be fixed tamper-resistant
- bi-directional fixing by turning the torque wrench
- push through ratchet 3/4" with smallest swivel angle 6°
- with robust, matt steel tube
- with very noticeable and audible ("click") signal
- nonslip QUATROLIT®-2C-handle
- according to EN ISO 6789:2017 Part 1, Typ II Class A
- with traceable declaration of conformance
- tripping accuracy +- 4%

20

3/4"



2179-S safety cap

Code	Number	□	Head	Measuring range Nm	Graduation Nm	Measuring range ft.lb.	Graduation ft.lb.	l/mm	Pieces	Weight/g	
2070005001000	2070-500	3/4"	Push through ratchet	100-500	25	80-400	1,25	910	1	3600	
2070008001000	2070-800	3/4"	Push through ratchet	160-800	40	120-600	2	1220	1	4550	
2070010001000	2070-1000	3/4"	Push through ratchet	200-1000	50	150-750	2,5	1230	1	4550	
2179000001000	2179-S	Safety cap for model 2179 2070 2080 2034								1	10

05

2080-2100

TORQUE WRENCH 1" WITH VERNIER SCALE

- for controlled torque application from 400 - 2100 Nm
- main measurement unit for Nm with vernier scale, auxiliary measurement unit for ft.-lb.
- Safe locking of the adjusted torque value by securing button at the handle end
- ELORA-No. 2179-S: exchanging the locking knob through the safety cap, the torque can be fixed tamper-resistant
- for clockwise fixing
- reversible ratchet 1" with smallest swivel angle 6°
- with very noticeable and audible ("click") signal
- Extension Bar with nonslip QUATROLIT®-2C-handle
- according to EN ISO 6789:2017 Part 1, Typ II Class A
- with traceable declaration of conformance
- tripping accuracy +- 4%

25

1"



2179-S safety cap



Code	Number	□	Head	Measuring range Nm	Graduation Nm	Measuring range ft.lb.	Graduation ft.lb.	l/mm	Pieces	Weight/g	
2080021001000	2080-2100	1"	Reversible ratchet	400-2100	100	300-1500	5	1945	1	10750	
2179000001000	2179-S	Safety cap for model 2179 2070 2080 2034								1	10

2178-20

TORQUE RATCHET, 1/4" WITH VERNIER SCALE

- for controlled torque application from 4 - 20 Nm
- main unit Nm, secondary unit ft.lb, both with Nonius
- safe locking of the set torque value
- for clockwise fixing
- with robust, matt-chrome plated steel tube
- reversible ratchet
- very noticeable and audible ("click") signal
- according to DIN EN ISO 6789:2017 Part 1, Typ II Class A
- Classified according to DIN EN ISO 6789: 2003 Type II Class A
- with traceable declaration of conformance
- Tripping accuracy +- 4%

6,3

1/4"



05

Code	Number	□	Measuring range Nm	Graduation Nm	Measuring range ft.lb.	Graduation ft.lb.	l/mm	Pieces	Weight/g
2178000201000	2178-20	1/4"	4-20	0,1	3,3-14,4	0,07	320	1	900

2011-1000

TORQUE SCREWDRIVER, 1/4" WITH VERNIER SCALE

- for controlled torque application from 2 - 10 Nm
- a disengaging coupler indicates the achievement of the release moment and prevents overtightening of the screw
- 1/4" internal hexagon socket for 1/4" bits according to DIN 3126-C 6,3
- bi-directional tightening
- safe locking of the adjusted torque value by securing button at the handle end
- 1/4" square socket at the end of the screwdriver ensuring support of power transmission
- according to EN ISO 6789:2017 Part 1, Typ II Class D
- with traceable declaration of conformance
- tripping accuracy +- 6% from the set value

6,3

1/4"



Code	Number	Measuring range Nm	Graduation Nm	l/mm	Pieces	Weight/g
2011010001000	2011-1000	2-10	0,2	160	1	330

2033-20

TORQUE WRENCH WITH RECTANGULAR INTAKE

- for use with ELORA interchangeable spanner heads
- main measurement unit for Nm with vernier scale, secondary measurement unit for ft-lb
- safe locking of the set torque value
- bi-directional fixing by turning the torque wrench
- with robust, matt steel tube
- with very noticeable and audible (‘click’) signal
- nonslip QUATROLIT®-2C-handle
- factory depth gauges: $S_s = 17,5$ mm (9 x 12 mm) and $S_s = 25$ mm (14 x 18 mm)
- according to DIN EN ISO 6789:2017 Part 1, Typ II Class A
- with traceable declaration of conformance
- tripping accuracy + - 4%

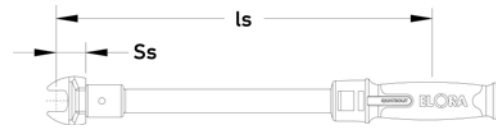

Code	Number	Drive mm	l_s mm	Measuring range Nm	Graduation Nm	Measuring range in.lb.	Graduation in.lb.	l/mm	Pieces	Weight/g
2033000201000	2033-20	9x12	282,5	4-20	0,1	39,8-172,6	0,9	315	1	595

2034-...

TORQUE WRENCH WITH RECTANGULAR INTAKE

- for use with ELORA interchangeable spanner heads
- main measurement unit for Nm with vernier scale, secondary measurement unit for ft.-lb.
- safe locking of the adjusted torque value by securing button at the handle end
- ELORA-No. 2179-S: exchanging the locking knob through the safety cap, the torque can be fixed tamper-resistant
- for clockwise and anti-clockwise tightening by turning the torque wrench
- with robust, matt steel tube
- with very noticeable and audible (‘click’) signal
- nonslip QUATROLIT®-2C-handle
- factory depth gauges: $S_s = 17,5$ mm (9 x 12 mm) and $S_s = 25$ mm (14 x 18 mm)
- according to DIN EN ISO 6789:2017 Part 1, Typ II Class A
- with traceable declaration of conformance
- tripping accuracy + - 4%



Code	Number	Drive mm	l_s mm	Measuring range Nm	Graduation Nm	Measuring range ft.lb.	Graduation ft.lb.	l/mm	Pieces	Weight/g
2034000601000	2034-60	9x12	314,5	10-60	0,25	9-45	4	345	1	1000
2034001251000	2034-125	9x12	370,5	25-125	0,25	20-90	5	438	1	900
2034002001000	2034-200	14x18	410,0	40-200	0,5	30-150	10	455	1	1198
2034003351000	2034-335	14x18	470,0	65-335	0,75	50-250	10	515	1	1305

05

Expert knowledge on insert tools

When using insert tools, it is essential to take into account the stated extension.
 If the extension for the insert tool to be used is exactly the same as the work calibration extension ($S_s = 17,5$ mm for 9 x 12 mm mounts and $S_s = 25$ mm for 14 x 18 mm mounts) of the torque wrench, the torque level you have set will be correct.
 Where insert tools having a different extension value are to be used, the set torque M_I will have to be calculated to ensure that the required target torque (M_s) is, in fact, achieved.

This can be done using the following formula:

$$\frac{M_s \times l_s}{l_s + S_v - S_s} = M_I$$

Where:

- M_s target torque
- l_s lever length of the torque wrench + works calibration extension
- S_v extension of the insert tool
- S_s works calibration extension ($S_s = 17,5$ mm for 9 x 12 mm mounts and $S_s = 25$ mm for 14 x 18 mm mounts)
- M_I torque setting on the wrench

2072-..., 2076-1

RATCHET INSERT TOOL, FINE TOOTH

- with small robust head
- forged, fine tooth gear wheel with handy metal switching disc
- 5° smallest swivel angle
- with locking pin
- chrome vanadium 31CrV3 / 1.2208
- male square according to DIN 3120, ISO 1174, with ball locking device

6,3	10	12,5
1/4"	3/8"	1/2"

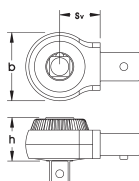

05

Code	Number	■	Drive mm	S _v mm	b mm	h mm	Pieces	Weight/g
2072000010000	2072-1	1/4"	9x12	17,5	25	16	1	80
2072000020000	2072-2	3/8"	9x12	17,5	34	22	1	160
2072000030000	2072-3	1/2"	9x12	17,5	34	23	1	170
2076000010000	2076-1	1/2"	14x18	25	41	30	1	339

2074-..., 2078-1

FIXED SQUARE INSERT TOOL

- forged with locking pin
- chrome-plated
- chrome vanadium 31CrV3 / 1.2208
- male square according to DIN 3120, ISO 1174, with ball locking device

6,3	10	12,5
1/4"	3/8"	1/2"

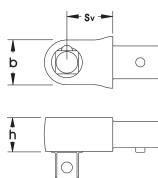

Code	Number	■	Drive mm	S _v mm	b mm	h mm	Pieces	Weight/g
2074000010000	2074-1	1/4"	9x12	17,5	13	12	1	50
2074000020000	2074-2	3/8"	9x12	17,5	19	16	1	89
2074000030000	2074-3	1/2"	9x12	17,5	19	16	1	115
2078000010000	2078-1	1/2"	14x18	25	25	19	1	206

2052-..., 2056-...

OPEN END SPANNER INSERT TOOL

- attention, changes setting value for ELORA-Nr. 2052-14 -19 and 2056-27 - 41
- forged
- with locking pin
- chrome-plated
- chrome vanadium 31CrV3 / 1.2208

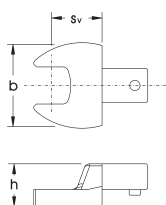

Code	Number	mm	Drive mm	S _v mm	b mm	h mm	Pieces	Weight/g
2052000070000	2052-7	7	9x12	17,5	20,7	14,7	1	46
2052000080000	2052-8	8	9x12	17,5	22	14,7	1	47
2052000090000	2052-9	9	9x12	17,5	23,5	14,7	1	45
2052000100000	2052-10	10	9x12	17,5	24,8	14,7	1	49
2052000110000	2052-11	11	9x12	17,5	26	14,7	1	52
2052000120000	2052-12	12	9x12	17,5	27,5	14,7	1	47
2052000130000	2052-13	13	9x12	17,5	28,8	14,7	1	53
2052000140000	2052-14	14	9x12	20	31,5	14,7	1	64
2052000150000	2052-15	15	9x12	20	33,5	14,7	1	65
2052000160000	2052-16	16	9x12	20	36	14,7	1	71
2052000170000	2052-17	17	9x12	20	37,7	14,7	1	69
2052000180000	2052-18	18	9x12	20	39	14,7	1	70
2052000190000	2052-19	19	9x12	20	41,6	14,7	1	74
2056000130000	2056-13	13	14x18	25	29,6	21,5	1	128
2056000140000	2056-14	14	14x18	25	31,3	21,5	1	125
2056000150000	2056-15	15	14x18	25	33,4	21,5	1	126
2056000160000	2056-16	16	14x18	25	35,8	21,5	1	135
2056000170000	2056-17	17	14x18	25	37	21,5	1	146
2056000180000	2056-18	18	14x18	25	38,6	21,5	1	144
2056000190000	2056-19	19	14x18	25	40,6	21,5	1	147
2056000210000	2056-21	21	14x18	25	45,2	21,5	1	162
2056000220000	2056-22	22	14x18	25	47,3	21,5	1	170
2056000240000	2056-24	24	14x18	25	50,8	21,5	1	187
2056000270000	2056-27	27	14x18	32,5	58,7	21,5	1	252
2056000300000	2056-30	30	14x18	32,5	62,7	21,5	1	266
2056000320000	2056-32	32	14x18	32,5	65,2	21,5	1	265
2056000340000	2056-34	34	14x18	32,5	66,5	21,5	1	252
2056000360000	2056-36	36	14x18	32,5	66,5	21,5	1	255
2056000380000	2056-38	38	14x18	32,5	66,5	21,5	1	244
2056000410000	2056-41	41	14x18	40	82,5	21,5	1	333

2062-..., 2066-...

RING SPANNER INSERT TOOL

- attention, changes setting value for ELORA-Nr. 2066-27 to 41
- forged
- with locking pin
- chrome-plated
- chrome vanadium 31CrV3 / 1.2208

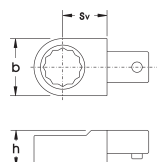

Code	Number	mm	Drive mm	S _v mm	b mm	h mm	Pieces	Weight/g
206200070000	2062-7	7	9x12	17,5	13,1	14,7	1	48
206200080000	2062-8	8	9x12	17,5	13,1	14,7	1	47
2062000100000	2062-10	10	9x12	17,5	17,6	14,7	1	51
2062000110000	2062-11	11	9x12	17,5	19	14,7	1	51
2062000120000	2062-12	12	9x12	17,5	20,3	14,7	1	61
2062000130000	2062-13	13	9x12	17,5	21,1	14,7	1	61
2062000140000	2062-14	14	9x12	17,5	23,4	14,7	1	64
2062000150000	2062-15	15	9x12	17,5	24,4	14,7	1	65
2062000160000	2062-16	16	9x12	17,5	26,4	14,7	1	68
2062000170000	2062-17	17	9x12	17,5	27,4	14,7	1	69
2062000180000	2062-18	18	9x12	17,5	28,9	14,7	1	71
2062000190000	2062-19	19	9x12	17,5	31	14,7	1	74
2062000210000	2062-21	21	9x12	17,5	33,4	14,7	1	81
2062000220000	2062-22	22	9x12	17,5	35	14,7	1	82
2066000130000	2066-13	13	14x18	25	21	21,5	1	135
2066000140000	2066-14	14	14x18	25	23	21,5	1	138
2066000150000	2066-15	15	14x18	25	26	21,5	1	138
2066000160000	2066-16	16	14x18	25	26	21,5	1	139
2066000170000	2066-17	17	14x18	25	27,5	21,5	1	144
2066000180000	2066-18	18	14x18	25	29,5	21,5	1	146
2066000190000	2066-19	19	14x18	25	31	21,5	1	150
2066000210000	2066-21	21	14x18	25	33	21,5	1	160
2066000220000	2066-22	22	14x18	25	35	21,5	1	155
2066000240000	2066-24	24	14x18	25	38	21,5	1	170
2066000270000	2066-27	27	14x18	31	42	21,5	1	217
2066000300000	2066-30	30	14x18	31	45,1	21,5	1	221
2066000320000	2066-32	32	14x18	31	48	21,5	1	224
2066000340000	2066-34	34	14x18	31	51	21,5	1	255
2066000360000	2066-36	36	14x18	31	53	21,5	1	248
2066000410000	2066-41	41	14x18	31	59,3	21,5	1	255

2063-...

OPEN RING SPANNER INSERT TOOL

- forged
- with locking pin
- chrome-plated
- chrome vanadium 31CrV3 / 1.2208



Code	Number	Ø mm	Drive mm	S _v mm	b mm	h mm	Pieces	Weight/g
2063000100000	2063-10	10	9x12	17,5	21,2	14,5	1	63
2063000110000	2063-11	11	9x12	17,5	22,6	14,5	1	63
2063000120000	2063-12	12	9x12	17,5	24,1	14,5	1	65
2063000130000	2063-13	13	9x12	17,5	25,2	14,5	1	64
2063000140000	2063-14	14	9x12	17,5	27,3	14,5	1	68
2063000160000	2063-16	16	9x12	17,5	30,1	14,5	1	71
2063000170000	2063-17	17	9x12	17,5	31,6	14,5	1	73
2063000180000	2063-18	18	9x12	17,5	33,3	15	1	78
2063000190000	2063-19	19	9x12	17,5	34,6	15	1	80
2063000210000	2063-21	21	9x12	17,5	37,7	15	1	81
2063000220000	2063-22	22	9x12	17,5	39,3	15	1	86

05

2071-...

ADAPTER

- attention, changes setting value
- for use with insert tools 9x12 mm and 14x8 mm
- forged
- chrome-plated
- chrome vanadium 31CrV3 / 1.2208



Code	Number	Female Square mm	Male Square	S _v mm	b mm	h mm	Pieces	Weight/g
2071000010000	2071-1	9x12	14x18	22	22	17	1	94
2071000020000	2071-2	14x18	9x12	35,25	30	23	1	127

2034-200 S13M

TORQUE WRENCH SET

- ▶ 13 pcs.
- ▶ in black plastic case with foamed inlay



05

Code	Number	Contents	Pieces	Weight/g
2034501301200	2034-200 S13M	2034-200 Torque Wrench with Rectangular Intake 2076-1 Ratchet Insert Tool, fine tooth 1/2" 14x18 2056- Open End Spanner Insert Tool 13, 14, 16, 17, 18, 19, 22, 24, 27, 30, 32 mm Open End Spanner Insert Tool 14x18	1	3500



2420-...

ELOTRONIC TORQUE WRENCH

- indicating torque wrench for controlled tightening from 20 - 340 Nm
- measurement units: Nm, ft-lb or in-lb
- bi-directional fixing
- huge easy to read 4 digit numerical LCD Display
- audible buzzer and optical signal (3 bright LED's) when target torque is reached
- 2 different measurement modes (Track Mode, Peak Hold)
- Battery operated (4xAA batteries)

12,5

1/2"



- serial computer interface, 2 way communication with computer, printer (protocol RS232C 9600BPS, 8,1,n)
- fine tooth ratchet, smallest possible swivel angle 5°
- male square according to DIN 3120 A 12,5, ISO 1174, with ball locking device
- with robust, matt steel tube with plastic handle
- according to EN ISO 6789:2017 Part 1, Typ I Class B
- with traceable declaration of conformance
- Display deviation +- 2%

Code	Number	■	Measuring range Nm	Measuring range in.lb.	Measuring range ft.lb.	l/mm	Pieces	Weight/g
2420002002000	2420-EDS200	1/2"	20-200	180-1800	15-150	458	1	1260
2420003402000	2420-EDS340	1/2"	34-340	300-3000	25-250	559	1	1550
2420500602000	2420-RS	Contents: 4 rechargeable batteries, cable for serial port RS 232, power supply					1	500

05

2400-...

ELOMETER TORQUE WRENCH WITH DRAG INDICATOR

- indicating torque wrench with dial gauge and drag indicator
- for controlled tightening from 0,7 - 2800 Nm
- measurement units: Nm, ft.-lb. or in.-lb.
- bi-directional fixing
- with fixed head square according to DIN 3120, ISO 1174
- ELORA No. 2400 UDS 1400 and 2400-UDS 2800 with additional audible buzzer
- in dependence EN ISO 6789:2017 part 1, type I class B
- with traceable declaration of conformance
- Display deviation +- 3%

2400-UDS2800

6,3	10	12,5
1/4"	3/8"	1/2"
20	25	
3/4"	1"	



Code	Number	■	Measuring range Nm	Graduation Nm	Measuring range in.lb.	Graduation in.lb.	Measuring range ft.lb.	Graduation ft.lb.	Signal	l/mm	Pieces	Weight/g
240000032000	2400-UDS3	1/4"	0,7-3,5	0,1	6-30	0,5	-	-	-	270	1	725
240000092000	2400-UDS9	1/4"	1,8-9	0,2	15-75	1	-	-	-	270	1	725
240000182000	2400-UDS18	3/8"	4-18	0,5	30-150	2	-	-	-	270	1	725
240000302000	2400-UDS30	3/8"	6-30	0,5	50-250	5	-	-	-	270	1	725
240000702000	2400-UDS70	3/8"	14-70	2	-	-	10-50	1	-	270	1	725
2400002402000	2400-UDS240	1/2"	50-250	5	-	-	35-175	5	-	560	1	1400
2400003502000	2400-UDS350	1/2"	70-350	10	-	-	50-250	5	-	560	1	1400
2400004802000	2400-UDS480	3/4"	100-480	10	-	-	70-350	10	-	675	1	3200
2400008002000	2400-UDS800	3/4"	160-800	20	-	-	120-600	10	-	1180	1	4500
2400014002000	2400-UDS1400	1"	300-1400	25	-	-	200-1000	20	optical and audible	1970	1	9000
2400028002000	2400-UDS2800	1"	600-2800	50	-	-	400-2000	40	optical and audible	3200	1	21000

2184-...

TORQUE ANGLE GAUGE

- for controlled screw tightening with fitting torque wrench at specified torque and torque angle
- torque angle from 0 – 360°
- 1/2" reading accuracy 2 degrees, 3/4" reading accuracy 5 degrees
- maximum load 1/2" 390 Nm, 3/4" 1330 Nm
- with flexible magnetic holder
- square with ball locking device
- **attention, do not exceed the maximum torque of the specific torque wrench!**

12,5

20

1/2"

3/4"



05

Code	Number	□	■	Graduation	∅	l/mm	Pieces	Weight/g
2184000012000	2184-1	1/2"	1/2"	2°	68	360	1	333
2184000022000	2184-2	3/4"	3/4"	5°	90	380	1	865

2601-...

TORQUE MULTIPLIER

- up to 10.000 Nm
- planetary gear (1-, 2- or 3-stepped)
- specially hardened gear wheels
- permanent internal greasing
- sliding bearings on drive side and power take-off side
- overload protection (one additional sun wheel with overload cutout is included)
- exchangeable drive heads
- matt chrome-plated /phosphated surfaces
- torque multipliers 2601-3 until 2601-6 are all fitted with a return stop
- bi-directional actuation
- highest torque, high accuracy better than +-5% tolerance
- **attention, only for static actuation!**
- in waterproof case



- Product-Features:**
- for clockwise and anticlockwise use
 - no extremely long levers required any more
 - uniform transmission of forces protects nuts and bolts
 - reduced risk of personal injury
 - compact, durable construction
 - low weight
 - no external power supply required
 - guaranteed accuracy: ±5%
 - long-term accuracy
 - low-maintenance construction
 - good value for money
 - ideal in conjunction ELORA torque wrenches
 - a range of supports available



05

Code	Number	max. output capacitance Nm	max. input capacitance Nm	○	■	Torque Ratio	Gear reduction	Return stop	Ø mm	l/mm	Weight without case and brace support	Weight with case and brace support	Pieces
2601100010000	2601-1	1500	416	1/2"	1"	1:3,6	4:1	-	90	150	3000	5400	1
2601100020000	2601-2	1500	416	3/4"	1"	1:3,6	4:1	-	90	150	3000	5400	1
2601100030000	2601-3	3500	269	3/4"	1"	1:13	16:1	x	95	200	5200	7400	1
2601100040000	2601-4	4500	264	3/4"	1.1/2"	1:17	20:1	x	120	215	7700	14500	1
2601100050000	2601-5	7000	159	3/4"	1.1/2"	1:44	59:1	x	130	272	13000	25500	1
2601100060000	2601-6	10000	181	3/4"	1.1/2"	1:55	74:1	x	148	272	14500	27000	1

2602

TORQUE MULTIPLIER

- perfect tool for heavy duty vehicles
- 1 step planetary gear
- 2 braces included
- robust construction
- surfaces matt-chrome plated/ gunmetal-finish
- bi-directional actuation
- accuracy better than +-4%
- **attention, only for static actuation!**
- in black plastic case



Code	Number	max. output capacitance Nm	max. output capacitance ft. lb.	○	■	Torque Ratio	Gear reduction	Pieces	Weight/g
2602000001000	2602	2700	2000	3/4"	1"	1:4,33	5:1	1	7400



SCREWDRIVERS

Cranked Keys _____	Page 252
Screwdrivers _____	Page 265
Variant Screwdrivers _____	Page 275
Screwdrivers with wooden handles _____	Page 277



6 shelves on top of each other, 30 next to each other, 2 opposite and this in each of the ten aisles – this is where our 20 warehouse experts find more than 8,000 ELORA items for daily dispatch.

159-..., 159A-...

HEXAGON KEY

- for inside hexagon screws
- ELORA-No. 159-0,7 up to 1,3 gunmetal finished, all other Sizes nickel plated
- ELORA-Chrome-Vanadium 59CrMoV4 / 1.2242
- DIN ISO 2936



Code	Number	l/mm ┌┐	Pieces 📦	Weight/g ⚖️	Code	Number	l/mm ┌┐	Pieces 📦	Weight/g ⚖️
015900003007	159-0,7	33 x 7	48	0,4	0159100023000	159A-1/16	46,5 x 15,5	48	1
015900003009	159-0,9	33 x 11	48	0,5	0159100033000	159A-5/64	52 x 18	48	2
0159000013000	159-1,0	33 x 11	48	0,5	0159100043000	159A-3/32	58,5 x 20,5	48	4
0159000133001	159-1,3	41 x 13	48	0,7	0159100053000	159A-7/64	66 x 23	24	5
0159000153001	159-1,5	46,5 x 15,5	48	1	0159100063000	159A-1/8	66 x 23	24	5
0159000023000	159-2	52 x 18	48	2	0159100073000	159A-9/64	69,5 x 25,5	24	8
0159000253001	159-2,5	58,5 x 20,5	48	4	0159100083000	159A-5/32	74 x 29	24	10
0159000033000	159-3	66 x 23	24	5	0159100093000	159A-3/16	85 x 33	24	18
0159000353001	159-3,5	69,5 x 25,5	24	8	0159100113000	159A-7/32	91 x 36	24	21
0159000043000	159-4	74 x 29	24	10	0159100133000	159A-1/4	96 x 38	24	30
0159000453001	159-4,5	80 x 30,5	24	15	0159100153000	159A-9/32	102 x 41	24	43
0159000053000	159-5	85 x 33	24	18	0159100173000	159A-5/16	108 x 44	12	59
0159000553001	159-5,5	85 x 33	24	24	0159100183000	159A-11/32	114 x 47	12	79
0159000063000	159-6	96 x 38	24	30	0159100193000	159A-3/8	122 x 50	12	103
0159000073000	159-7	102 x 41	24	43	0159100213000	159A-7/16	129 x 53	12	131
0159000083000	159-8	108 x 44	12	59	0159100233000	159A-1/2	145 x 63	12	215
0159000093000	159-9	114 x 47	12	79	0159100243000	159A-9/16	154 x 70	6	260
0159000103000	159-10	122 x 50	12	103	0159100263000	159A-5/8	168 x 76	6	400
0159000113000	159-11	129 x 53	12	131	0159100283000	159A-3/4	199 x 89	3	620
0159000123000	159-12	137 x 57	12	160	0159100313000	159A-7/8	222 x 102	3	950
0159000133000	159-13	145 x 63	12	215	0159100343000	159A-1	277 x 127	1	1740
0159000143000	159-14	154 x 70	6	260					
0159000153000	159-15	161 x 73	6	290					
0159000163000	159-16	168 x 76	6	400					
0159000173000	159-17	177 x 80	6	430					
0159000183000	159-18	188 x 84	6	510					
0159000193000	159-19	199 x 89	3	620					
0159000203000	159-20	200 x 90	3	650					
0159000213000	159-21	211 x 96	3	860					
0159000223000	159-22	222 x 102	3	950					
0159000243000	159-24	248 x 114	1	1250					
0159000273000	159-27	277 x 127	1	1740					
0159000303000	159-30	315 x 142	1	2460					
0159000323000	159-32	347 x 157	1	3080					
0159000363000	159-36	391 x 176	1	4370					

159L-..., 159LA-...

HEXAGON KEY, EXTRA LONG

- ▶ for inside hexagon screws
- ▶ extra long
- ▶ nickel plated
- ▶ ELORA-Chrome-Vanadium
59CrMoV4 / 1.2242
- ▶ DIN ISO 2936



Code	Number	l/mm	Pieces	Weight/g
0159010153001	159L-1,5	91,5 x 15,5	48	2
0159010023000	159L-2	102 x 18	48	4
0159010253001	159L-2,5	114,5 x 20,5	48	6
0159010033000	159L-3	129 x 23	24	9
0159010043000	159L-4	144 x 29	24	19
0159010053000	159L-5	165 x 33	24	33
0159010063000	159L-6	186 x 38	24	54
0159010073000	159L-7	197 x 41	24	80
0159010083000	159L-8	208 x 44	12	115
0159010093000	159L-9	219 x 47	12	148
0159010103000	159L-10	234 x 50	12	185
0159010113000	159L-11	247 x 53	12	247
0159010123000	159L-12	262 x 57	12	295
0159010133000	159L-13	277 x 63	12	370
0159010143000	159L-14	294 x 70	6	460
0159010173000	159L-17	337 x 80	6	750
0159010193000	159L-19	379 x 89	3	1100

Code	Number	l/mm	Pieces	Weight/g
0159110023000	159LA-1/16	91,5 x 15,5	48	2
0159110033000	159LA-5/64	102 x 18	48	4
0159110043000	159LA-3/32	114,5 x 20,5	48	6
0159110063000	159LA-1/8	129 x 23	24	9
0159110083000	159LA-5/32	144 x 29	24	19
0159110093000	159LA-3/16	165 x 33	24	33
0159110133000	159LA-1/4	186 x 38	24	54
0159110153000	159LA-9/32	197 x 41	24	80
0159110173000	159LA-5/16	208 x 44	12	115
0159110183000	159LA-11/32	219 x 47	12	148
0159110193000	159LA-3/8	234 x 50	12	185
0159110213000	159LA-7/16	247 x 53	12	247
0159110233000	159LA-1/2	277 x 63	12	370
0159110263000	159LA-5/8	337 x 80	6	750
0159110283000	159LA-3/4	379 x 89	3	1100
further sizes on request				

159S-...M, 159S-...A

HEXAGON KEY SET

- ▶ for inside hexagon screws
- ▶ in black plastic wallet
- ▶ nickel plated
- ▶ ELORA-Chrome-Vanadium
59CrMoV4 / 1.2242
- ▶ DIN ISO 2936



Code	Number	Contents	Pieces	Weight/g
0159500803000	159S-8M	159- 1,5, 2, 2,5, 3, 4, 5, 6, 8 mm	12	135
0159501003000	159S-10M	159- 1,5, 2, 2,5, 3, 4, 5, 6, 8, 10, 12 mm	6	410
0159501403000	159S-14M	159- 1,5, 2, 2,5, 3, 4, 5, 6, 8, 10, 12, 14, 17, 19, 22 mm	1	2720

Code	Number	Contents	Pieces	Weight/g
0159600803000	159S-8A	159A- 1/16, 5/64, 3/32, 1/8, 5/32, 3/16, 7/32, 1/4 AF	12	96
0159601003000	159S-10A	159A- 1/16, 5/64, 3/32, 1/8, 5/32, 3/16, 7/32, 1/4, 5/16, 3/8 AF	6	250
0159601403000	159S-14A	159A- 1/16, 5/64, 3/32, 1/8, 5/32, 3/16, 7/32, 1/4, 5/16, 3/8, 1/2, 9/16, 5/8, 3/4 AF	1	1814

159SK-9M, 159SK-10M

HEXAGON KEY SET

- ▶ for inside hexagon screws
- ▶ in plastic holder
- ▶ nickel plated
- ▶ ELORA-Chrome-Vanadium
59CrMoV4 / 1.2242
- ▶ DIN ISO 2936

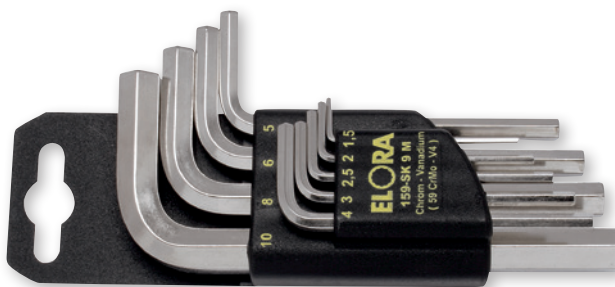

Code	Number	Contents	Pieces	Weight/g
0159500093000	159SK-9M	159- 1,5, 2, 2,5, 3, 4, 5, 6, 8, 10 mm	3	250
0159500103000	159SK-10M	159- 1,5, 2, 2,5, 3, 4, 5, 6, 8, 10, 12 mm	3	415

159S-...L-9L, 159S-...LA

HEXAGON KEY SET, EXTRA LONG

- ▶ for inside hexagon screws
- ▶ in plastic holder
- ▶ nickel plated
- ▶ ELORA-Chrome-Vanadium
59CrMoV4 / 1.2242
- ▶ DIN ISO 2936



Code	Number	Contents	Pieces	Weight/g	Code	Number	Contents	Pieces	Weight/g
0159510703000	159S-7L	159L- 1,5, 2, 2,5, 3, 4, 5, 6 mm	1	148	0159610903000	159 S-9LA	159LA- 1/16, 5/64, 3/32, 1/8, 5/32, 3/16, 1/4, 5/16, 3/8 AF	1	428
0159510903000	159S-9L	159L- 1,5, 2, 2,5, 3, 4, 5, 6, 8, 10 mm	1	428					

159S-8P

HEXAGON KEY SET

- ▶ for inside hexagon screws
- ▶ in plastic storage box
- ▶ nickel plated
- ▶ ELORA-Chrome-Vanadium
59 CrMoV 4 / 1.2242
- ▶ DIN ISO 2936



Code	Number	Contents	Pieces	Weight/g
0159500901000	159S-8P	159- 2, 2,5, 3, 4, 5, 6, 8, 10 mm	1	336

159SK-...

HEXAGON KEY SET

- ▶ for inside hexagon screws
- ▶ metal holder
- ▶ nickel plated
- ▶ ELORA-Chrome-Vanadium 59CrMoV4 / 1.2242
- ▶ DIN ISO 2936



Code	Number	Contents	l/mm	Pieces	Weight/g
0159500013000	159SK-1	2,5, 3, 4, 5, 6, 8 mm	115	3	235
0159500023000	159SK-2	2,5, 3, 4, 5, 6, 8, 10 mm	115	3	320
0159500033000	159SK-3	1,5, 2, 2,5, 3, 4, 5, 6 mm	95	3	150
0159500043000	159SK-4	3, 4, 5, 6, 8, 10 mm	115	3	360

Code	Number	Contents	l/mm	Pieces	Weight/g
0159500053000	159SK-5	1/16, 5/64, 3/32, 1/8, 5/32, 3/16, 7/32 AF	95	3	165
0159500063000	159SK-6	1/8, 5/32, 3/16, 7/32, 1/4, 5/16 AF	110	3	220
0159500073000	159SK-7	3/16, 7/32, 1/4, 5/16, 3/8 AF	120	3	360
0159500083000	159SK-8	3/32, 3/16, 7/32, 1/4, 5/16, 3/8 AF	120	3	370

159S-KK...

HEXAGON KEY SET

- ▶ for inside hexagon screws
- ▶ plastic holder with elevating mechanism
- ▶ nickel plated
- ▶ ELORA-Chrome-Vanadium 59CrMoV4 / 1.2242
- ▶ DIN ISO 2936



Code	Number	Contents	l/mm	Pieces	Weight/g
0159510013000	159S-KK-1	2,5, 3, 4, 5, 6, 8 mm	120	3	150
0159510023000	159S-KK-2	2,5, 3, 4, 5, 6, 8, 10 mm	130	3	220
0159510033000	159S-KK-3	1,5, 2, 2,5, 3, 4, 5, 6 mm	130	3	320

158R-...

HEXAGON KEY SET

- ▶ for inside hexagon screws
- ▶ sorted on metal ring
- ▶ nickel plated
- ▶ ELORA-Chrome-Vanadium 59CrMoV4 / 1.2242
- ▶ DIN ISO 2936



Code	Number	Contents	Pieces	Weight/g
0158500803000	158R-1	2, 2,5, 3, 4, 5, 6, 8, 10 mm	1	257
0158500813000	158R-2	1,5, 2, 2,5, 3, 4, 5, 6 mm	1	75
0158600803000	158R-3	1/16, 5/64, 3/32, 1/8, 5/32, 3/16, 7/32, 1/4 AF	1	105

155-...

HEXAGON KEY WITH T-HANDLE

- ▶ for inside hexagon screws
- ▶ blades nickel plated
- ▶ with black T-Handle and suspension hole
- ▶ ELORA-Chrome-Vanadium 59CrV4 / 1.2242
- ▶ DIN ISO 2936

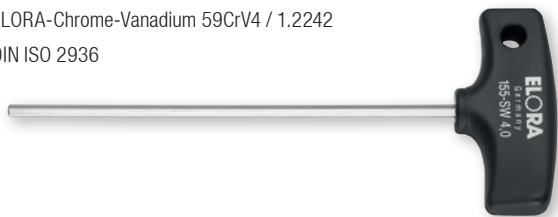

Code	Number	DIN 912	l/mm	Pieces	Weight/g
0155002091200	155-2-90	M 2,5	90	6	27
0155002101200	155-2,5-100	M 3	100	6	28
0155003101200	155-3-100	M 4	100	6	32
0155003151200	155-3-150	M 4	150	6	36
0155003201200	155-3-200	M 4	200	6	40
0155004101200	155-4-100	M 5	100	6	38
0155004151200	155-4-150	M 5	150	6	54
0155004201200	155-4-200	M 5	200	6	50
0155005101200	155-5-100	M 6	100	6	46
0155005151200	155-5-150	M 6	150	6	54
0155005201200	155-5-200	M 6	200	6	62
0155006101200	155-6-100	M 8	100	6	82
0155006151200	155-6-150	M 8	150	6	94
0155006201200	155-6-200	M 8	200	6	106
0155008101200	155-8-100	M 10	100	6	108
0155008151200	155-8-150	M 10	150	6	130
0155008201200	155-8-200	M 10	200	6	150
0155010101200	155-10-100	M 12	100	6	120
0155010201200	155-10-200	M 12	200	6	215
0155012101200	155-12-100	M 14	100	6	160
0155012201200	155-12-200	M 14	200	6	275
0155012251200	155-12-250	M 14	250	6	320
0155014301200	155-14-300	M 16	250	6	490

159W-...

HEXAGON KEY WITH T-HANDLE

- ▶ for inside hexagon screws
- ▶ blades nickel plated
- ▶ 2C T-handle with lateral drive and suspension hole
- ▶ ELORA-Chrome-Vanadium 59CrV4 / 1.2242
- ▶ DIN ISO 2936



Code	Number	DIN 912	l/mm	Pieces	Weight/g
0159005023000	159W-2	M 2,5	100 x 13	12	18
0159005023005	159W-2,5	M 3	100 x 13	12	20
0159005033000	159W-3	M 4	100 x 13	12	23
0159005043000	159W-4	M 5	150 x 15	12	45
0159005053000	159W-5	M 6	150 x 15	12	58
0159005063000	159W-6	M 8	200 x 17	6	100
0159005083000	159W-8	M 10	200 x 17	6	150
0159005103000	159W-10	M 12	200 x 22	6	240

159SW

HEXAGON KEY SET

- ▶ for inside hexagon screws
- ▶ in workshop stand
- ▶ blades nickel plated
- ▶ 2C T-Handle with lateral drive and suspension hole
- ▶ ELORA-Chrome-Vanadium 59CrV4 / 1.2242



Code	Number	Contents	Pieces	Weight/g
0159600701000	159-SW	159W- 2x100, 2,5x100, 3x100, 4x150, 5x150, 6x200, 8x200	1	1100

159Z-...

HEXAGON KEY WITH PIN

- ▶ for inside hexagon screws with bore hole
- ▶ nickel plated
- ▶ Chrome-Vanadium 59CrV4 / 1.2242



Code	Number	l/mm	Pieces	Weight/g
0159020033000	159Z-3	66 x 23	24	5
0159020043000	159Z-4	74 x 29	24	10
0159020053000	159Z-5	85 x 33	24	18
0159020063000	159Z-6	96 x 38	24	30
0159020073000	159Z-7	102 x 41	24	43
0159020083000	159Z-8	108 x 44	12	59
0159020093000	159Z-9	105 x 38	12	75
0159020103000	159Z-10	122 x 50	12	103
0159020123000	159Z-12	137 x 57	12	160
0159020243000	159Z-24	248 x 114	1	1238
0159020273000	159Z-27	277 x 127	1	1740

You will find the matching OMS-26 module on page no. 34

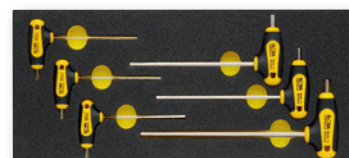

159KU-..., 159KUA-...

BALL END HEXAGON KEY, EXTRA LONG

- for inside hexagon screws
- for use in awkward areas
- swivel angel up to 30°
- ball profile on the long side
- nickel plated
- Chrome-Vanadium 59CrMoV4 / 1.2242
- DIN ISO 2936



mm

AF"

Code	Number	DIN 912	l/mm	Pieces	Weight/g	Code	Number	l/mm	Pieces	Weight/g
0159030153000	159KU-1,5	M 1,6 M 2	81,5 x 14,5	48	2	0159130023000	159KUA-1/16	81,5 x 14,5	48	2
0159030023000	159KU-2	M 2,5	87 x 18	48	3	0159130033000	159KUA-5/64	87 x 18	48	4
0159030253000	159KU-2,5	M 3	92,5 x 9,5	48	5	0159130043000	159KUA-3/32	92,5 x 19,5	48	6
0159030033000	159KU-3	M 4	103 x 22	24	7	0159130063000	159KUA-1/8	103 x 22	24	9
0159030043000	159KU-4	M 5	114 x 29	24	15	0159130083000	159KUA-5/32	114 x 29	24	18
0159030053000	159KU-5	M 6	133 x 32	24	27	0159130093000	159KUA-3/16	133 x 32	24	27
0159030063000	159KU-6	M 8	156 x 36	24	46	0159130113000	159KUA-7/32	142,5 x 32,5	24	40
0159030083000	159KU-8	M 10	178 x 43	12	92	0159130133000	159KUA-1/4	156 x 36	12	48
0159030103000	159KU-10	M 12	200 x 50	12	128	0159130173000	159KUA-5/16	178 x 43	12	97
0159030123000	159KU-12	M 14	226 x 57	12	265	0159130193000	159KUA-3/8	200 x 50	12	133
						0159130233000	159KUA-1/2	293 x 63	12	360

159SKU E

BALL END HEXAGON KEY SET, EXTRA LONG

- in plastic holder
- for inside hexagon screws
- for use in awkward areas
- swivel angel up to 30°
- ball profile on the long side
- nickel plated
- Chrome-Vanadium 59CrMoV4 / 1.2242
- DIN ISO 2936



mm



Code	Nummer	Contents	Pieces	Weight/g
0159530903002	159SKU E	159KU E- 1,5, 2, 2,5, 3, 4, 5, 6, 8, 10 mm	3	380

159SKU

BALL END HEXAGON KEY SET, EXTRA LONG

- in 2C-plastic holder
- for inside hexagon screws
- for use in awkward areas
- swivel angel up to 30°
- ball profile on the long side
- nickel plated
- Chrome-Vanadium 59CrMoV4 / 1.2242
- DIN ISO 2936



mm



Code	Nummer	Contents	Pieces	Weight/g
0159530903000	159SKU	159KU- 1,5, 2, 2,5, 3, 4, 5, 6, 8, 10 mm	3	414

159SKU C

BALL END HEXAGON KEY SET, EXTRA LONG

- in plastic holder
- every size is assigned to its own colour
- for inside hexagon screws
- for use in awkward areas
- swivel angel up to 30°
- ball profile on the long side
- nickel plated
- Chrome-Vanadium 59CrMoV4 / 1.2242
- DIN ISO 2936



Code	Number	Contents	Pieces	Weight/g
0159535903001	159SKU C	159KU C- 1,5, 2, 2,5, 3, 4, 5, 6, 8, 10 mm	3	430

159S-KUB

BALL END HEXAGON KEY SET, EXTRA LONG

- in foldable plastic holder
- for inside hexagon screws
- for use in awkward areas
- swivel angel up to 30°
- ball profile on the long side
- nickel plated
- Chrome-Vanadium 59CrMoV4 / 1.2242
- DIN ISO 2936



Code	Number	Contents	Pieces	Weight/g
0159535903000	159S-KUB	159KU- 1,5, 2, 2,5, 3, 4, 5, 6, 8, 10 mm	3	430

162S-TXKU

TORX®-BALL END KEY SET

- in plastic holder
- for inside TORX® screws
- for use in awkward areas
- swivel angle up to 25°
- ball profile on the long side
- gunmetal finished
- Chrome-Vanadium 59CrMoV4 / 1.2242
- TORX® = reg. trademark of Acument Intellectual Properties, LLC. USA



Code	Number	Contents	Pieces	Weight/g
0162530805100	162S-TXKU	162TXKU- 9, 10, 15, 20, 25, 27, 30, 40	1	181

162TX-...

TORX®-KEY, SHORT

- for inside TORX® screws
- gunmetal finished
- Chrome-Vanadium 59CrMoV4 / 1.2242
- TORX® = reg. trademark of Acument Intellectual Properties, LLC. USA



Code	Number	★mm	l/mm	mm	Pieces	Weight/g
0162000055100	162TX-5	1,42	44,5 x 18,5	M 1,8	12	2
0162000065100	162TX-6	1,69	44,5 x 18,5	M 2	12	2
0162000075100	162TX-7	1,99	50,5 x 18,5	M 2,5	12	2
0162000085100	162TX-8	2,31	51 x 19	M 2,5	12	3
0162000095100	162TX-9	2,50	51 x 19	M 3	12	3
0162000105100	162TX-10	2,79	54 x 20	M 3	12	4
0162000155100	162TX-15	3,27	57,5 x 21,5	M 3,5	12	5
0162000205100	162TX-20	3,86	61 x 23	M 4	12	7
0162000255100	162TX-25	4,43	64,5 x 24,5	M 5	12	10
0162000275100	162TX-27	4,99	69,5 x 26,5	M 5	12	15
0162000305100	162TX-30	5,52	76 x 30	M 6	12	20
0162000405100	162TX-40	6,65	83 x 33	M 8	12	30
0162000455100	162TX-45	7,82	91 x 37	M 8	12	43
0162000505100	162TX-50	8,83	104 x 41	M 10	12	65
0162000555100	162TX-55	11,22	120 x 47	M 12	12	120
0162000605100	162TX-60	13,25	134 x 52	M 14	12	190

162LTX...

TORX®-KEY, LONG

- for inside TORX® screws
- gunmetal finished
- Chrome-Vanadium 59CrMoV4 / 1.2242
- TORX® = reg. trademark of Acument Intellectual Properties, LLC. USA



Code	Number	★mm	l/mm	mm	Pieces	Weight/g
0162010055100	162LTX-5	1,42	72 x 13	M 1,8	12	4
0162010065100	162LTX-6	1,69	80 x 15	M 2	12	4
0162010075100	162LTX-7	1,99	88 x 18	M 2,5	12	4
0162010085100	162LTX-8	2,31	101 x 20	M 2,5	12	6
0162010095100	162LTX-9	2,5	111 x 21	M 3	12	6
0162010105100	162LTX-10	2,74	121 x 23	M 3	12	6
0162010155100	162LTX-15	3,27	136 x 27	M 3,5	12	9
0162010205100	162LTX-20	3,86	148 x 29	M 4	12	12
0162010255100	162LTX-25	4,43	163 x 33	M 5	12	17
0162010275100	162LTX-27	4,99	170 x 36	M 5	12	24
0162010305100	162LTX-30	5,52	178 x 38	M 6	12	40
0162010405100	162LTX-40	6,65	188 x 43	M 8	12	59
0162010455100	162LTX-45	7,82	195 x 46		12	93
0162010505100	162LTX-50	8,83	200 x 50	M 10	12	130

162SLTX

TORX®-KEY SET, LONG

- in plastic holder
- for inside TORX® screws
- gunmetal finished
- Chrome-Vanadium 59CrMoV4 / 1.2242
- TORX® = reg. trademark of Acument Intellectual Properties, LLC. USA



Code	Number	Contents	Pieces	Weight/g
0162511305100	162S-LTX	162LTX- 5, 6, 7, 8, 9, 10, 15, 20, 25, 27, 30, 40, 50	3	440

162S-KTX

TORX®-KEY SET

- ▶ metal holder, nickel plated
- ▶ for inside TORX® screws
- ▶ gunmetal finished
- ▶ Chrome-Vanadium 59CrMoV4 / 1.2242
- ▶ TORX® = reg. trademark of Acument Intellectual Properties, LLC. USA



Code	Number	Contents	l/mm	Pieces	Weight/g
0162500005100	162S-KTX	162TX- 9, 10, 15, 20, 25, 27, 30, 40	110	1	273

162-KKTX

TORX®-KEY SET

- ▶ plastic holder with elevating mechanism
- ▶ for inside TORX® screws
- ▶ gunmetal finished
- ▶ Chrome-Vanadium 59CrMoV4 / 1.2242
- ▶ TORX® = reg. trademark of Acument Intellectual Properties, LLC. USA



Code	Number	Contents	l/mm	Pieces	Weight/g
0162500105100	162S-KKTX	162TX- 9, 10, 15, 20, 25, 27, 30, 40	130	1	241

762TX-...

TORX®-KEY WITH T-HANDLE

- ▶ for inside TORX® screws
- ▶ blade matt chrome plated, tip gunmetal finished
- ▶ black plastic-T-handle with suspension hole
- ▶ TX-6 to TX-45: Chrome-Vanadium 61CrSiV5 / 1.2243
- ▶ TX-50 and TX-60: Chrome-Vanadium 59CrV4 / 1.2242
- ▶ TORX® = reg. trademark of Acument Intellectual Properties, LLC. USA



Code	Number	★ mm	l/mm	mm	Pieces	Weight/g
0762000065100	762TX-6	1,69	80	M 2	6	34
0762000075100	762TX-7	1,99	80	M 2,5	6	34
0762000085100	762TX-8	2,31	80	M 2,5	6	34
0762000095100	762TX-9	2,5	80	M 3	6	34
0762000105100	762TX-10	2,74	100	M 3	6	38
0762000155100	762TX-15	3,27	100	M 3,5	6	38
0762000205100	762TX-20	3,86	100	M 4	6	38
0762000255100	762TX-25	4,43	105	M 5	6	72
0762000275100	762TX-27	4,99	105	M 5	6	74
0762000305100	762TX-30	5,52	125	M 6	6	102
0762000405100	762TX-40	6,65	125	M 8	6	116
0762000455100	762TX-45	7,82	125	M 8	6	130
0762000505100	762TX-50	8,83	125	M 8	6	130
0762000605100	762TX-60	13,25	125	M 10	6	150

762-TX20/300

TORX®-KEY WITH T-HANDLE, EXTRA LONG

- ▶ for inside TORX® screws
- ▶ gunmetal finished
- ▶ black plastic-T-handle with suspension hole
- ▶ Chrome-Vanadium 61CrSiV5 / 1.2243
- ▶ TORX® = reg. trademark of Acument Intellectual Properties, LLC. USA



Code	Number	★ mm	l/mm	mm	Pieces	Weight/g
0762000205101	762TX-20/300	5,52	350	M 4	6	120

762-TX30/300

TORX®-KEY WITH T-HANDLE, EXTRA LONG

- ▶ for inside TORX® screws
- ▶ blade matt chrome plated, tip gunmetal finished
- ▶ black plastic-T-handle with suspension hole
- ▶ Chrome-Vanadium 61CrSiV5 / 1.2243
- ▶ TORX® = reg. trademark of Acument Intellectual Properties, LLC. USA



Code	Number	★ mm	l/mm	mm	Pieces	Weight/g
0762000305101	762TX-30/300	5,52	300	M 6	6	110

162WTX-...

TORX®-KEY WITH T-HANDLE

- for inside TORX® screws
- blade matt chrome plated, tip gunmetal finished
- 2C T-handle with lateral drive and suspension hole
- Chrome-Vanadium 59CrMoV4 / 1.2242
- TORX® = reg. trademark of Acument Intellectual Properties, LLC. USA



Code	Number	★ mm	l/mm	mm	Pieces	Weight/g
0162020095100	162WTX-9	2,50	100 x 13	M 3	12	22
0162020105100	162WTX-10	2,74	100 x 13	M 3	12	22
0162020155100	162WTX-15	3,27	100 x 13	M 3,5	12	26
0162020205100	162WTX-20	3,86	150 x 15	M 4	12	44
0162020255100	162WTX-25	4,43	150 x 15	M 5	12	49
0162020275100	162WTX-27	4,99	150 x 15	M 5	12	62
0162020305100	162WTX-30	5,52	150 x 17	M 6	12	82
0162020405100	162WTX-40	6,65	150 x 17	M 8	12	100

162-SWTX

TORX®-KEY SET WITH T-HANDLE

- Workshop display
- for inside TORX® screws
- blade matt chrome plated, tip gunmetal finished
- 2C T-handle with lateral drive and suspension hole
- Chrome-Vanadium 59CrMoV4 / 1.2242
- TORX® = reg. trademark of Acument Intellectual Properties, LLC. USA



Code	Number	Contents	Pieces	Weight/g
0162600801000	162-SWTX	TORX®-Hexagon Keys 162WTX- 9x100, 10x100, 15x100, 20x150, 25x150, 27x150, 30x150, 40x150	1	1091

You will find the matching OMS-27 module on page no. 34

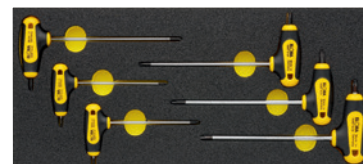

162S-KTTX

TORX®-KEY SET

- ▶ metal holder, nickel plated
- ▶ for inside TORX® safety screws
- ▶ with hole at drive end
- ▶ gunmetal finished
- ▶ Chrome-Vanadium 59 CrMoV 4 / 1.2242
- ▶ TORX® = reg. trademark of Acument Intellectual Properties, LLC. USA



Code	Number	Contents	l/mm	Pieces	Weight/g
0162540805100	162S-KTTX	162-TTX- 9, 10, 15, 20, 25, 27, 30, 40	110	1	273

162S-KKTTX

TORX®-KEY SET

- ▶ plastic holder with elevating mechanism
- ▶ for inside TORX® safety screws
- ▶ with hole at drive end
- ▶ gunmetal finished
- ▶ Chrome-Vanadium 59CrMoV4 / 1.2242
- ▶ TORX® = reg. trademark of Acument Intellectual Properties, LLC. USA



Code	Number	Contents	l/mm	Pieces	Weight/g
0162550805100	162S-KKTTX	162TTX- 9, 10, 15, 20, 25, 27, 30, 40	130	1	260

762TTX-...

TORX®-KEY WITH T-HANDLE

- ▶ for inside TORX® safety screws
- ▶ with hole at drive end
- ▶ blade matt chrome plated, tip gunmetal finished
- ▶ black plastic-T-handle with suspension hole
- ▶ Chrome-Vanadium 61CrSiV5 / 1.2243
- ▶ TORX® = reg. trademark of Acument Intellectual Properties, LLC. USA



Code	Number	★mm	l/mm	mm	Pieces	Weight/g
0762010085100	762TTX-8	2,31	80	M2,5	6	34
0762010095100	762TTX-9	2,5	80	M3	6	34
0762010105100	762TTX-10	2,74	100	M3	6	38
0762010155100	762TTX-15	3,27	100	M3,5	6	38
0762010205100	762TTX-20	3,86	100	M4	6	38
0762010255100	762TTX-25	4,43	105	M5	6	72
0762010275100	762TTX-27	4,99	105	M5	6	74
0762010305100	762TTX-30	5,52	125	M6	6	102
0762010405100	762TTX-40	6,65	125	M8	6	116
0762010455100	762TTX-45	7,82	125	M8	6	130

160S-KXZN

OFFSET KEY SET

- for inside multi-point B&S and XZN screws
- metal holder with elevating mechanism
- nickel plated
- Chrome-Vanadium 59CrV4 / 1.2242

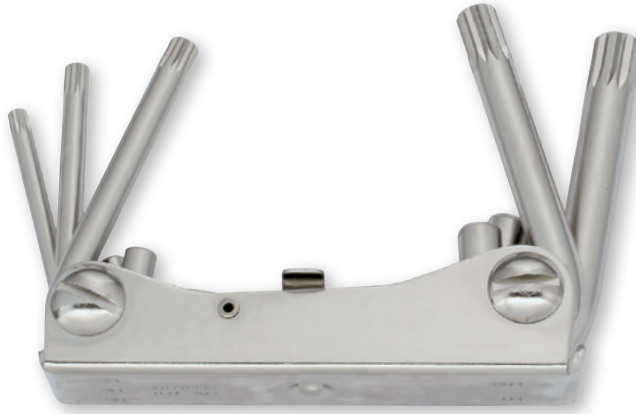

Code	Number	Contents	l/mm	Pieces	Weight/g
0160500003000	160S-KXZN	Winkelschraubendreher 5, 6, 8, 10, 12	120	3	420

730-...

OFFSET KEY

- for cross slotted screws
- matt chrome plated, tip gunmetal finished
- Chrome-Vanadium 59CrV4 / 1.2242
- according to DIN 5208,
blade according to DIN ISO 8764-1 PH



Code	Number	Number	l/mm	Pieces	Weight/g
0730000011001	730-1	1+2	100	6	26
0730000031001	730-3	3+4	200	6	116

740-...

OFFSET KEY

- for plain slotted screws
- matt chrome plated
- Chrome-Vanadium 59CrV4 / 1.2242
- according to DIN 5200,
blade according to DIN ISO 2380







Code	Number	Edge	l/mm	Pieces	Weight/g
0740000041001	740-4	4,0 x 0,8	100	6	18
0740000051001	740-5,5	5,5 x 1,0	125	6	34
0740000081001	740-8	8,0 x 1,2	150	6	52

539/1-IS...

SCREWDRIVER

- for plain slotted screws
- matt chrome plated hexagon blade with forged hexagon section
- through hardened
- blade edge gunmetal finished
- nonslip QUATROLIT®-2C-handle
- with suspension hole
- blade made from ELORA-Special steel 73MoV5 / 1.2381
- according to DIN ISO 2380-2, blade tip according to DIN ISO 2380-1







Code	Number	Edge mm	 mm	 mm	Hexagon mm	Pieces 	Weight/g 
0539021005600	539/1-IS 100	1,0 × 5,5	100	190	10	6	74
0539021255600	539/1-IS 125	1,2 × 6,5	125	220	13	6	115
0539021505600	539/1-IS 150	1,2 × 8,0	150	260	13	6	175
0539021755600	539/1-IS 175	1,6 × 10,0	175	290	13	6	190
0539022005600	539/1-IS 200	2,0 × 12,0	200	325	16	6	300
0539022505600	539/1-IS 250	2,5 × 14,0	250	375	16	6	340

539-IS

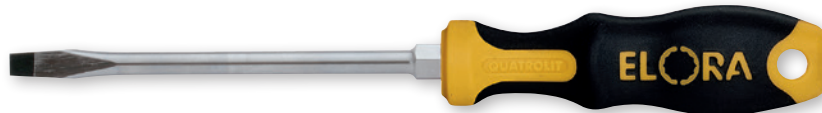
SCREWDRIVER

- for plain slotted screws
- matt chrome plated forged blade with forged hexagon section
- through hardened
- blade edge gunmetal finished
- nonslip QUATROLIT®-2C-handle
- with suspension hole
- blade made from ELORA-Chrome-Vanadium 59CrV4 / 1.2242
- according to DIN ISO 2380-2, blade tip according to DIN ISO 2380-1





Code	Number	Edge mm	 mm	 mm	Hexagon mm	Pieces 	Weight/g 
0539020755500	539-IS 75	0,6 × 3,5	75	160	6	6	38
0539020905500	539-IS 90	0,8 × 4,0	90	175	6	6	40
0539021005500	539-IS 100	1,0 × 5,5	100	190	8	6	52
0539021255500	539-IS 125	1,2 × 6,5	125	220	10	6	86
0539021505500	539-IS 150	1,2 × 8,0	150	260	13	6	132
0539021755500	539-IS 175	1,6 × 10,0	175	290	13	6	174
0539022005500	539-IS 200	2,0 × 12,0	200	325	16	6	275
0539022505500	539-IS 250	2,5 × 14,0	250	375	16	6	317

545-ST IS...

SCREWDRIVER, "STAINLESS"

- for plain slotted screws
- forged blade
- through hardened
- no galvanic surface treatment
- nonslip QUATROLIT®-2C-handle
- with suspension hole
- blade made from ELORA-Stainless Steel X46Cr13 / 1.4034
- according to DIN ISO 2380-2, blade tip according to DIN ISO 2380-1







Code	Number	Edge mm	 mm	 mm	Pieces 	Weight/g 
0545020757000	545-ST IS 75	0,6 × 3,5	75	160	6	38
0545021007000	545-ST IS 100	0,8 × 4,0	100	190	6	40
0545021257000	545-ST IS 125	1,0 × 5,5	125	215	6	52
0545021507000	545-ST IS 150	1,2 × 6,5	150	250	6	86
0545021757000	545-ST IS 175	1,6 × 8,0	175	280	6	132
0545022007000	545-ST IS 200	1,6 × 10,0	200	315	6	174

545-IS...

SCREWDRIVER

- ▶ for plain slotted screws
- ▶ matt chrome plated forged blade
- ▶ through hardened
- ▶ blade edge gunmetal finished
- ▶ nonslip QUATROLIT®-2C-handle
- ▶ with suspension hole
- ▶ blade made from ELORA-Chrome-Vanadium 59CrV4 / 1.2242
- ▶ according to DIN ISO 2380-2, blade tip according to DIN ISO 2380-1







Code	Number	Edge mm	 mm	 mm	Pieces 	Weight/g 
0545020755500	545-IS 75	0,6 × 3,5	75	160	6	38
0545021005500	545-IS 100	0,8 × 4,0	100	190	6	40
0545021255500	545-IS 125	1,0 × 5,5	125	210	6	60
0545021505500	545-IS 150	1,2 × 6,5	150	245	6	78
0545021755500	545-IS 175	1,6 × 8,0	175	280	6	127
0545022005500	545-IS 200	1,6 × 10,0	200	315	6	150
0545022505500	545-IS 250	2,0 × 12,0	250	375	6	220
0545023005500	545-IS 300	2,0 × 14,0	300	425	6	285

649-IS...

ELECTRICIANS SCREWDRIVER

- ▶ for plain slotted screws
- ▶ matt chrome plated forged blade
- ▶ through hardened
- ▶ blade edge gunmetal finished
- ▶ nonslip QUATROLIT®-2C-handle
- ▶ with suspension hole
- ▶ up to IS 75: blade made from ELORA-Special steel 73MoV5 / 1.2381
- ▶ all other made from ELORA-Chrome-Vanadium 59CrV4 / 1.2242
- ▶ according to DIN ISO 2380-2, blade tip according to DIN ISO 2380-1







Code	Number	Edge mm	 mm	 mm	Pieces 	Weight/g 
0649020605500	649-IS 60	0,4 × 2,5	60	145	6	30
0649020755500	649-IS 75	0,5 × 3,0	75	160	6	32
0649021005500	649-IS 100	0,6 × 3,5	100	185	6	36
0649021085500	649-IS 108	0,8 × 4,0	100	185	6	40
0649021255500	649-IS 125	1,0 × 5,5	125	210	6	60
0649021505500	649-IS 150	1,0 × 5,5	150	235	6	66
0649021755500	649-IS 175	1,0 × 5,5	175	260	6	70
0649022005500	649-IS 200	1,0 × 5,5	200	295	6	84
0649023005500	649-IS 4,5x300	0,8 × 4,5	300	385	6	70
0649023005501	649-IS 6,0x300	1,0 × 6,0	300	395	6	114

559/1-PH...

SCREWDRIVER

- ▶ for cross slotted screws
- ▶ matt chrome plated hexagon blade with forged hexagon section
- ▶ through hardened
- ▶ tip gunmetal finished
- ▶ nonslip QUATROLIT®-2C-handle
- ▶ with suspension hole
- ▶ blade made from ELORA-Special steel 73MoV5 / 1.2381
- ▶ according to DIN ISO 8764, tip according to DIN ISO 8764-1 PH







Code	Number	 mm	 mm	Hexagon mm	Pieces 	Weight/g 
0559020015600	559/1-PH 1	80	165	8	6	72
0559020025600	559/1-PH 2	100	195	10	6	106
0559020035600	559/1-PH 3	150	255	13	6	175
0559020045600	559/1-PH 4	200	325	16	6	295

559-PH...

SCREWDRIVER

- for cross slotted screws
- matt chrome plated forged blade with forged hexagon section
- through hardened
- tip gunmetal finished
- nonslip QUATROLIT®-2C-handle
- with suspension hole
- blade made from ELORA-Chrome-Vanadium 59CrV4 / 1.2242
- according to DIN ISO 8764, tip according to DIN ISO 8764-1 PH







Code	Number	 mm	 mm	Hexagon mm	Pieces 	Weight/g 
0559020015500	559-PH 1	80	165	6	6	40
0559020025500	559-PH 2	100	195	10	6	74
0559020035500	559-PH 3	150	255	13	6	131
0559020045500	559-PH 4	200	325	16	6	277

547-ST PH...

SCREWDRIVER, "STAINLESS"

- for cross slotted screws
- forged blade
- through hardened
- no galvanic surface treatment
- nonslip QUATROLIT®-2C-handle
- with suspension hole
- blade made from ELORA-Stainless Steel X46Cr13 / 1.4034
- according to DIN ISO 8764, tip according to DIN ISO 8764-1 PH







Code	Number	 mm	 mm	Pieces 	Weight/g 
0547020007000	547-ST PH 0	60	145	6	23
0547020017000	547-ST PH 1	80	165	6	40
0547020027000	547-ST PH 2	100	195	6	65
0547020037000	547-ST PH 3	150	265	6	128

547-PH...

SCREWDRIVER

- for cross slotted screws
- matt chrome plated forged blade
- through hardened
- tip gunmetal finished
- nonslip QUATROLIT®-2C-handle
- with suspension hole
- PH0 = blade made of ELORA-Special steel 73MoV52 / 1.2381
- PH1-4 = blade made of ELORA-Chrome-Vanadium 59CrV4 / 1.2242
- according to DIN ISO 8764, tip according to DIN ISO 8764-1 PH



Code	Number	 mm	 mm	Pieces 	Weight/g 
0547020005500	547-PH 0	60	145	6	23
0547020015500	547-PH 1	80	165	6	40
0547020025500	547-PH 2	100	195	6	65
0547020035500	547-PH 3	150	255	6	128
0547020045500	547-PH 4	200	315	6	212
0547020015530	547-PH 1x300*	300	395	6	187
0547020025530	547-PH 2x300*	300	405	6	250

569-PZ...

SCREWDRIVER

- for cross slotted screws
- matt chrome plated forged blade with forged hexagon section
- through hardened
- tip gunmetal finished
- nonslip QUATROLIT®-2C-handle
- with suspension hole
- blade made from ELORA-Chrome-Vanadium 59CrV4 / 1.2242
- according to DIN ISO 8764, tip according to DIN ISO 8764-1 PZ



Code	Number	mm	mm	Hexagon mm	Pieces 	Weight/g
0569020015500	569-PZ 1	80	165	6	6	40
0569020025500	569-PZ 2	100	195	10	6	68
0569020035500	569-PZ 3	150	255	13	6	129
0569020045500	569-PZ 4	200	325	16	6	212

549-PZ...

SCREWDRIVER

- for cross slotted screws
- matt chrome plated blade
- through hardened
- tip gunmetal finished
- nonslip QUATROLIT®-2C-handle
- with suspension hole
- PZ0 = blade made of ELORA-Special steel 73MoV52 / 1.2381
- PZ1-3 = blade made of ELORA-Chrome-Vanadium 61CrSiV5 / 1.2243
- PZ4 = blade made of ELORA-Chrome-Vanadium 59CrV4 / 1.2242
- according to DIN ISO 8764, tip according to DIN ISO 8764-1 PZ



Code	Number	mm	mm	Pieces 	Weight/g
0549020005500	549-PZ 0	60	145	6	23
0549020015500	549-PZ 1	80	165	6	40
0549020025500	549-PZ 2	100	195	6	68
0549020035500	549-PZ 3	150	255	6	129
0549020045500	549-PZ 4	200	315	6	212
0549020015530	549-PZ 1x300*	300	395	6	187
0549020025530	549-PZ 2x300*	300	405	6	250

543-IS...

SCREWDRIVER, SHORT VERSION

- for plain slotted screws
- matt chrome plated blade
- through hardened
- blade edge gunmetal finished
- plastic handle
- with suspension hole
- ELORA-Chrome-Vanadium 59CrV4 / 1.2242
- according to DIN ISO 2380-2A, blade edge according to DIN ISO 2380-1



Code	Number	Edge mm	mm	mm	Pieces 	Weight/g
0543020455500	543-IS 45	0,6 × 3,5	25	85	6	42
0543020605500	543-IS 60	1,0 × 5,5	25	85	6	42
0543020805500	543-IS 80	1,2 × 6,5	25	85	6	42

555-PH...

SCREWDRIVER, SHORT VERSION

- for cross slotted screws
- matt chrome plated blade
- through hardened
- tip gunmetal finished
- plastic handle
- with suspension hole
- ELORA-Chrome-Vanadium 59CrV4 / 1.2242
- according to DIN ISO 8764, tip according to DIN ISO 8764-1 PH



554-PZ...

SCREWDRIVER, SHORT VERSION

- for cross slotted screws
- matt chrome plated blade
- through hardened
- tip gunmetal finished
- plastic handle
- with suspension hole
- ELORA-Chrome-Vanadium 59CrV4 / 1.2242
- according to DIN ISO 8764, tip according to DIN ISO 8764-1 PZ



Code	Number	mm	mm	Pieces	Weight/g
0555020015500	555-PH 1	25	85	6	42
0555020025500	555-PH 2	25	85	6	42
0555020035500	555-PH 3	25	85	6	42

Code	Number	mm	mm	Pieces	Weight/g
0554020015500	554-PZ 1	25	85	6	42
0554020025500	554-PZ 2	25	85	6	42
0554020035500	554-PZ 3	25	85	6	42

575-...

SCREWDRIVER WITH BALL END

- for inside hexagon screws
- matt chrome plated blade
- through hardened
- tip gunmetal finished
- maximum swivel angle 20°
- nonslip QUATROLIT®-2C-handle
- with suspension hole
- blade made of ELORA-Chrome-Vanadium 59CrV4 / 1.2242
- according to DIN ISO 2936



Code	Number	mm	mm	mm	Pieces	Weight/g
0575020027100	575-2	M 2,5	100	185	6	25
0575020257100	575-2,5	M3	100	175	6	27
0575020037100	575-3	M4	100	185	6	30
0575020047100	575-4	M5	100	185	6	51
0575020057100	575-5	M6	100	185	6	75
0575020067100	575-6	M8	125	220	6	90
0575020087100	575-8	M10	140	255	6	145
0575020107100	575-10	M12	140	265	6	220
0575020127100	575-12	M14	150	275	6	310

573TX-...

SCREWDRIVER WITH BALL END

- for inside TORX® screws
- matt chrome plated blade
- through hardened
- tip gunmetal finished
- maximum swivel angle 20°
- nonslip QUATROLIT®-2C-handle
- with suspension hole
- blade made of ELORA-Chrom-Vanadium 61CrSiV5 / 1.2243
- TORX® = reg. trademark of Acument Intellectual Properties, LLC. USA



Code	Number	mm	mm	mm	mm	Pieces	Weight/g
0573020091000	573-9	2,50	60	135	M3	6	33
0573020101000	573-10	2,74	80	165	M3	6	47
0573020151000	573-15	3,27	80	165	M3,5	6	45
0573020201000	573-20	3,86	100	185	M4	6	50
0573020251000	573-25	4,43	100	185	M5	6	52
0573020271000	573-27	4,99	115	200	M5	6	62
0573020301000	573-30	5,52	115	200	M6	6	70
0573020401000	573-40	6,65	130	235	M8	6	118

760TX-...

SCREWDRIVER

- for inside TORX® screws
- matt chrome plated blade
- through hardened
- tip gunmetal finished
- nonslip QUATROLIT®-2C-handle
- with suspension hole
- blade made of ELORA-Chrome-Vanadium 61CrSiV5 / 1.2243
- TORX® = reg. trademark of Acument Intellectual Properties, LLC. USA



Code	Number	mm	mm	mm	mm	Pieces	Weight/g
0760020031000	760TX-3	1,13	60	135	M1,2 - M1,4	6	30
0760020041000	760TX-4	1,29	60	135	M1,4	6	30
0760020051000	760TX-5	1,42	60	135	M1,8	6	30
0760020061000	760TX-6	1,69	60	135	M2	6	32
0760020071000	760TX-7	1,99	60	135	M2,5	6	32
0760020081000	760TX-8	2,31	60	135	M2,5	6	33
0760020091000	760TX-9	2,50	60	135	M3	6	33
0760020101000	760TX-10	2,74	80	165	M3	6	47
0760020151000	760TX-15	3,27	80	165	M3,5	6	45
0760020201000	760TX-20	3,86	100	185	M4	6	50
0760020251000	760TX-25	4,43	100	185	M5	6	52
0760020271000	760TX-27	4,99	115	200	M5	6	62
0760020301000	760TX-30	5,52	115	200	M6	6	70
0760020401000	760TX-40	6,65	130	235	M8	6	118

760 TX-30/300

SCREWDRIVER, EXTRA LONG

- for inside TORX® screws
- for low placed screw connections for e.g. instrument board and car body
- matt chrome plated blade
- through hardened
- tip gunmetal finished
- with suspension hole
- blade made of ELORA-Chrome-Vanadium 61CrSiV5 / 1.2243
- TORX® = reg. trademark of Acument Intellectual Properties, LLC. USA



Code	Number	mm	mm	mm	mm	Pieces	Weight/g
0760000301001	760TX- 30/300	5,52	320	430	M6	6	120

761TTX-...

SCREWDRIVER

- for inside TORX® safety screws
- with bore hole in tip
- matt chrome plated blade
- through hardened
- tip gunmetal finished
- nonslip QUATROLIT®-2C-handle
- with suspension hole
- blade made of ELORA-Chrome-Vanadium 61CrSiV5 / 1.2243
- TORX® = reg. trademark of Acument Intellectual Properties, LLC. USA

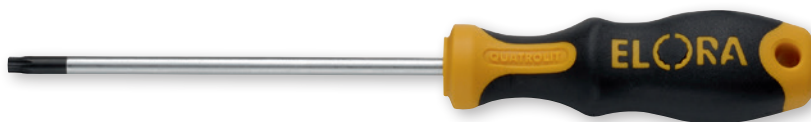

Code	Number	mm	mm	mm	mm	Pieces	Weight/g
0761020091000	761TTX-6	1,69	60	135	M2	6	33
0761020091000	761TTX-7	1,99	60	135	M2,5	6	33
0761020091000	761TTX-8	2,31	60	135	M2,5	6	33
0761020091000	761TTX-9	2,50	60	135	M3	6	33
0761020101000	761TTX-10	2,74	80	165	M3	6	33
0761020151000	761TTX-15	3,27	80	165	M3,5	6	45
0761020201000	761TTX-20	3,86	100	185	M4	6	50
0761020251000	761TTX-25	4,43	100	185	M5	6	52
0761020271000	761TTX-27	4,99	115	200	M5	6	62
0761020301000	761TTX-30	5,52	115	200	M6	6	70
0761020401000	761TTX-40	6,65	130	235	M8	6	118

237

MAGNETIZER-DEMAGNETIZER

- to magnetize and demagnetize screwdriver blades, tweezers and similar tools
- to magnetize direct the tool slowly through the "+" opening, to demagnetize tool direct slowly through the "-" opening
- high-quality plastic, shock resistant, cadmium free, with two C8-Industrial permanent magnets

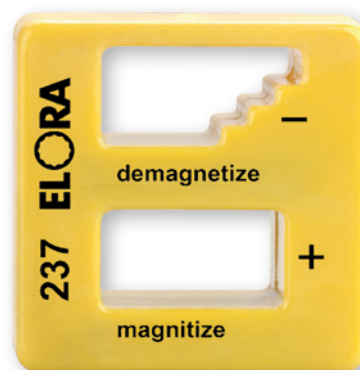

Code	Number	Pieces	Weight/g
0237000000000	237	6	85

579 S5-K, 581 S5-K

SCREWDRIVER SET

- 5 pcs.
- carton box packed
- matt chrome plated hexagon blade with forged hexagon section
- tip gunmetal finished
- nonslip QUATROLIT®-2C-handle
- with suspension hole



Code	Number	Contents	Pieces	Weight/g
0579520505500	579 S5-K	Screwdriver for plain slotted screws 539-IS 100, 125, 150 Screwdriver for cross slotted screws 559-PH 1, PH 2	1	520
0581520505500	581 S5-K	Screwdrivers for plain slotted screws 539-IS 100, 125, 150 Screwdriver for cross slotted screws 569-PZ 1, PZ 2	1	520

582 S5-K...

SCREWDRIVER SET

- 5 pcs.
- carton box packed
- matt chrome plated blade
- through hardened
- tip gunmetal finished
- nonslip QUATROLIT®-2C-handle
- with suspension hole



Code	Number	Contents	Pieces	Weight/g
0582520505501	582 S5-K-1	Screwdriver for plain slotted screws 545-IS 100, 125, 150 Screwdriver for cross slotted screws 549-PZ 1, PZ 2	1	400
0582520505502	582 S5-K-2	Screwdriver for plain slotted screws 545-IS 100, 125, 150 Screwdriver for cross slotted screws 547-PH1, PH2	1	400

583 S...

SCREWDRIVER SET

- 583 S5K=5 pcs.
- 583 S6K=6 pcs.
- in black plastic packaging with transparent cover
- matt chrome plated hexagon blade with forged hexagon section
- tip gunmetal finished
- nonslip QUATROLIT®-2C-handle
- with suspension hole



Code	Number	Contents	Pieces	Weight/g
0583520505500	583 S5-K	Screwdriver for plain slotted screws 539/1-IS 100, 125, 150 Screwdriver for cross slotted screws 559/1-PH 1, PH 2	1	380
0583520505501	583 S5-K-1	Screwdriver for plain slotted screws 539/1-IS 100, 125, 150 Screwdriver for cross slotted screws 559/1-PH 1, PH 2	1	660
0583520605500	583 S6-K	Screwdriver for plain slotted screws 545-IS 100, 125, 150 Screwdriver for cross slotted screws 547-PH 1, PH 2 Screwdriver, short version 543-IS 45	1	380

583 S6K-ST

SCREWDRIVER SET "STAINLESS"

- 6 pcs.
- carton box packed
- forged blade
- through hardened
- no galvanic surface treatment
- nonslip QUATROLIT®-2C-handle
- with suspension hole



Code	Number	Contents	Pieces	Weight/g
0583520607000	583 S6K-ST	Screwdriver for plain slotted screws 545-ST IS 75, 100, 125, 150 Screwdriver for cross slotted screws 547-ST PH 1, PH 2	1	440

583 S7-K...

SCREWDRIVER SET

- 7 pcs.
- carton box packed
- matt chrome plated hexagon blade with forged hexagon section
- tip gunmetal finished
- nonslip QUATROLIT®-2C-handle
- with suspension hole



Code	Number	Contents	Pieces	Weight/g
0583520705501	583 S7-K-1	Screwdriver for plain slotted screws 545-IS 75, 100, 125, 150 Screwdriver for cross slotted screws 549-PZ 1, PZ 2 Voltage Tester 561	1	460
0583520705502	583 S7-K-2	Screwdriver for plain slotted screws 545-IS 75, 100, 125, 150 Screwdriver for cross slotted screws 547-PH 1, PH 2 Voltage Tester 561	1	450

583 S6K...

SCREWDRIVER SET

- 6 pcs.
- carton box packed
- matt chrome plated blade
- through hardened
- tip gunmetal finished
- nonslip QUATROLIT®-2C-handle
- with suspension hole



Code	Number	Contents	Pieces	Weight/g
0583520605501	583 S6-K-1	Screwdriver for plain slotted screws 545-IS 75, 100, 125, 150 Screwdriver for cross slotted screws 549-PZ 1, PZ 2	1	440
0583520605502	583 S6-K-2	Screwdriver for plain slotted screws 545-IS 75, 100, 125, 150 Screwdriver for cross slotted screws 547-PH 1, PH 2	1	440

760/761STX-...

SCREWDRIVER SET

- 6 pcs.
- STX = for inside TORX® screws
- STTX = for inside TORX® safety screws
- matt chrome plated blade
- through hardened
- tip gunmetal finished
- nonslip QUATROLIT®-2C-handle
- with suspension hole
- blade made of ELORA-Chrome-Vanadium 61CrSiV5 / 1.2243
- TORX® = reg. trademark of Acument Intellectual Properties, LLC. USA



Code	Number	Contents	Pieces	Weight/g
0760520605501	760 STX-6K-1	Screwdriver 760-TX 6, 7, 8, 9, 10, 15	1	338
0760520605502	760 STX-6K-2	Screwdriver 760-TX 10, 15, 20, 25, 27, 30	1	396
0761520605501	761STTX-6K-1	Screwdrivers 761-TTX 6, 7, 8, 9, 10, 15	1	342
0761520605502	761STTX-6K-2	Screwdrivers 761-TTX 10, 15, 20, 25, 27, 30	1	397

06



You will find the matching OMS-modules on page no. 35-37



You will find the matching MS-modules on page no. 46-47



520

SCREWDRIVER HANDLE VARIANT

- hexagon bolster for 10 mm spanner drive and 6 mm hexagon chuck
- nonslip QUATROLIT®-2C-handle
- chuck and bolster made from special tool steel WX 69



Code	Number	l/mm	Pieces	Weight/g
0520020005500	520	95	6	42

535-IS 4

SCREWDRIVER BLADE VARIANT

- for plain slotted screws
- suitable for ELORA-No. 520
- hexagon blade matt chrome-plated
- through hardened
- ELORA-special steel 73MoV5 / 1.2381
- blade edge according to DIN ISO 2380-1



Code	Number	Hexagon Size mm	l/mm	Pieces	Weight/g
0535000405500	535-IS 4	6	175	6	39

551-PH...

SCREWDRIVER BLADE VARIANT

- for plain and cross slotted screws
- suitable for ELORA-No. 520
- hexagon blade matt chrome-plated
- through hardened
- ELORA-special steel 73MoV5 / 1.2381
- blade edge according to DIN ISO 2380-1
- tip according to DIN ISO 8764-1 PH

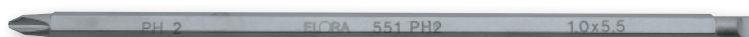

Code	Number	Hexagon Size mm	l/mm	Pieces	Weight/g
0551000015500	551-PH 1	6	175	6	39
0551000025500	551-PH 2	6	175	6	39
0551000035500	551-PH 3	6	175	6	39

557-PH 12

SCREWDRIVER BLADE VARIANT

- for cross slotted screws
- suitable for ELORA-No. 520
- hexagon blade matt chrome-plated
- through hardened
- ELORA-special steel 73MoV5 / 1.2381
- tip according to DIN ISO 8764-1 PH

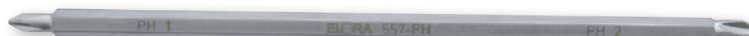

Code	Number	Hexagon Size mm	l/mm	Pieces	Weight/g
0557000005500	557-PH 12	6	175	6	39

552-PZ...

SCREWDRIVER BLADE VARIANT

- for plain and cross slotted screws
- suitable for ELORA-No. 520
- hexagon blade matt chrome-plated
- through hardened
- ELORA-special steel 73MoV5 / 1.2381
- blade edge according to DIN ISO 2380-1
- tip according to DIN ISO 8764-1 PZ

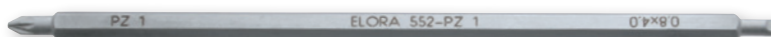

Code	Number	Hexagon Size mm	l/mm	Pieces	Weight/g
0552000015500	552-PZ 1	6	175	6	39
0552000025500	552-PZ 2	6	175	6	39
0552000035500	552-PZ 3	6	175	6	39

567-PZ 12

SCREWDRIVER BLADE VARIANT

- for cross slotted screws
- suitable for ELORA-No. 520
- hexagon blade matt chrome-plated
- through hardened
- ELORA-special steel 73MoV5 / 1.2381
- tip according to DIN ISO 8764-1 PZ



Code	Number		Hexagon Size mm	l/mm		Pieces	Weight/g
0567000005500	567-PZ 12	PZ1	6	175	PZ2	6	39

577-...

SCREWDRIVER BLADE VARIANT

- for inside hexagon screws
- suitable for ELORA-No. 520
- hexagon blade matt chrome-plated
- through hardened
- ELORA-special steel 73MoV5 / 1.2381
- according to DIN ISO 2936



Code	Number		Hexagon Size mm	l/mm		Pieces	Weight/g
0577000305500	577-3	KU3	6	175	IN3	6	38
0577000405500	577-4	KU4	6	175	IN4	6	39
0577000505500	577-5	KU5	6	175	IN5	6	40
0577000605500	577-6	KU6	6	175	IN6	6	40

527-TX...

SCREWDRIVER BLADE VARIANT

- for inside TORX® screws
- suitable for ELORA-No. 520
- hexagon blade matt chrome-plated
- through hardened
- ELORA-special steel 73MoV5 / 1.2381
- TORX® = reg. trademark of Acument Intellectual Properties, LLC. USA



Code	Number		Hexagon Size mm	l/mm		Pieces	Weight/g
0527000065500	527-TX 6,	TX 6	6	175	TX 8	6	39
0527000075500	527-TX 7	TX 7	6	175	TX 9	6	39
0527000105500	527-TX 10	TX 10	6	175	TX 15	6	39
0527000205500	527-TX 20	TX 20	6	175	TX 25	6	39
0527000305500	527-TX 30	TX 30	6	175	TX 40	6	39

527 S4

SCREWDRIVER SET VARIANT

- 4 pcs.
- for inside TORX® screws
- in black plastic wallet
- hexagon bolster for 10 mm spanner drive and 6 mm hexagon chuck
- nonslip QUATROLIT®-2C-handle
- with suspension hole
- hexagon blade matt chrome-plated
- through hardened
- ELORA-special steel 73MoV5 / 1.2381
- TORX® = reg. trademark of Acument Intellectual Properties, LLC. USA







Code	Number	Contents	Pieces	Weight/g
0527510405500	527 S4	Variant handle 520 Variant blade 527-TX 10 × TX 15 527-TX 20 × TX 25 527-TX 30 × TX 40	1	231

636-IS...

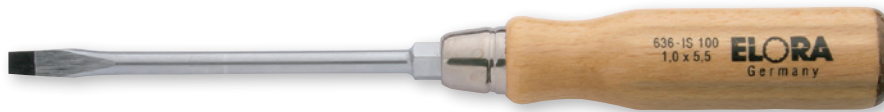
SCREWDRIVER

- for plain slotted screws
- matt chrome plated blade with forged hexagon section
- through hardened
- blade edge gunmetal finished
- wooden handle, clear lacquered with leather cap
- blade made from ELORA-Chrome-Vanadium 59CrV4 / 1.2242
- similar DIN ISO 2380-2, blade edge according to DIN ISO 2380-1







Code	Number	Edge mm			Hexagon mm	Pieces 	Weight/g 
0636000751000	636-IS 75	0,6 x 3,5	75	170	6	6	43
0636000901000	636-IS 90	0,8 x 4,5	90	185	6	6	50
0636001001000	636-IS 100	1,0 x 5,5	100	200	8	6	50
0636001251000	636-IS 125	1,2 x 6,5	125	235	10	6	110
0636001501000	636-IS 150	1,2 x 8,0	150	270	13	6	155
0636001751000	636-IS 175	1,6 x 10,0	175	300	13	6	200
0636002001000	636-IS 200	2,0 x 12,0	200	330	16	6	280
0636002501000	636-IS 250	2,5 x 14,0	250	390	16	6	340

656-PH...

SCREWDRIVER

- for cross slotted screws
- matt chrome plated blade with forged hexagon section
- through hardened
- tip gunmetal finished
- wooden handle, clear lacquered with leather cap
- blade made from ELORA-Chrome-Vanadium 59CrV4 / 1.2242
- similar DIN ISO 8764-2, tip according to DIN ISO 8764-1 PH







Code	Number			Hexagon mm	Pieces 	Weight/g 
0656000011000	656-PH 1	85	180	6	6	50
0656000021000	656-PH 2	100	210	10	6	85
0656000031000	656-PH 3	150	270	13	6	165
0656000041000	656-PH 4	200	330	16	6	280

658-PZ...

SCREWDRIVER

- for cross slotted screws
- matt chrome plated blade with forged hexagon section
- through hardened
- tip gunmetal finished
- wooden handle, clear lacquered with leather cap
- blade made from ELORA-Chrome-Vanadium 59CrV4 / 1.2242
- similar DIN ISO 8764-2, tip according to DIN ISO 8764-1 PZ



Code	Number			Hexagon mm	Pieces 	Weight/g 
0658000011000	658-PZ 1	85	180	6	6	50
0658000021000	658-PZ 2	100	210	10	6	85
0658000031000	658-PZ 3	150	270	13	6	165
0658000041000	658-PZ 4	200	330	16	6	280

676 S5-K / 677 S5-K

SCREWDRIVER SET

- 5 pcs.
- carton box packed
- matt chrome plated blade with forged hexagon section
- through hardened
- tip gunmetal finished
- wooden handle, clear lacquered with leather cap



Code	Number	Contents	Pieces	Weight/g
0676500509000	676 S5-K	Screwdriver for plain slotted screws 636-IS 100, 125, 150 Screwdriver for cross slotted screws 656-PH 1, PH 2	1	602
0677500509000	677 S5-K	Screwdriver for plain slotted screws 636-IS 100, 125, 150 Screwdriver for cross slotted screws 658-PZ 1, PZ 2	1	585

676 S7-K, 673 S7-K

SCREWDRIVER SET

- 7 pcs.
- carton box packed
- matt chrome plated blade with forged hexagon section
- through hardened
- tip gunmetal finished
- wooden handle, clear lacquered with leather cap



Code	Number	Contents	Pieces	Weight/g
0670500709000	670 S7-K	Screwdriver for plain slotted screws 636-IS 90, 100, 125, 150, 175 Screwdriver for cross slotted screws 656-PH 1, PH 2	1	844
0673500709000	673 S7-K	Screwdriver for plain slotted screws 636-IS 90, 100, 125, 150, 175 Screwdriver for cross slotted screws 658-PZ 1, PZ 2	1	850

You will find the matching OMS-16 module on page no. 37

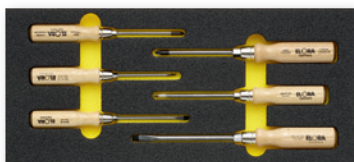

You will find the matching MS-41 module on page no. 48



You will find the matching OMS-17 module on page no. 38

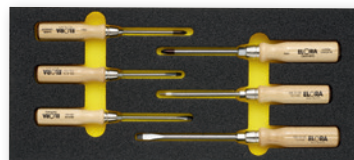

You will find the matching MS-40 module on page no. 48







ELECTRICIANS- AND FINE MECHANICS TOOLS

ESD-Tools _____	Page 282
Electronic and Fine Mechanics Tools _____	Page 298
Wire Stripping Tools and Cable Shears _____	Page 303
Electricians Safety Tools _____	Page 309



Some tasks require very specific tools. With our special tool sets, you are perfectly equipped for every application and have your helpers always at hand.



07

ESD stands for Electro Static Discharge. This means a brief, high discharge of electrical current, which results from large potential differences in an electrically insulating material. Often, the cause of this potential difference is the result of charging owing to static electricity that is not noticed by a human. Even the smallest charges can result in lasting damage to electronic components.

A complex set of measures contributes to countering this danger. For example, an EPA (Electrostatic Protected Area) workstation always aims at getting the electrostatic charge discharged to earth potential in a controlled manner.



ESD

Dissipative working clothes, the typical ESD armband with a spiral cable and electrostatically safe tools are standard components of such a workplace. These tools are marked accordingly.

Note:
ESD-tools from ELORA are not suitable for working on electrically live parts!

ESD tools from ELORA conform to the ESD-standard DIN IEC 61340-5-1. They are fitted with handles of special conductive material, whose surface resistance is in the range 10^6 to 10^9 Ohm. The handle size provides the required contact surface to the hand of the user to ensure that the discharging takes place in a “soft” manner that is gentle on the materials – sensitive components and assemblies remain fully functional despite the mechanical intervention of humans.

ELORA-ESD SPECIAL PLIERS. WELL THOUGHT-OUT TO THE SMALLEST DETAIL.

The comprehensive ELORA range of pliers meets the requirements of professional users. The antistatic, ergonomic and slip-resistant two-component handles facilitate safe guidance of the pliers and optimum transmission of force. ELORA ESD pliers are available with the most varied range of heads or jaws.

Production specification

The plier blanks are hot-forged in separate high-precision special dies within narrow tolerances. The result is a material quality which, because of its molecular structure, is far superior to punched or cold-formed blanks. We align the individual choice of materials according to the different demands of gripping or cutting pliers.

Gripping pliers are subject to torsional and bending forces as well as a greater stress on the surfaces and edges. Through the use of carbon steel C45, we achieve the optimum hardness value of 45 HRC.

Cutting pliers are highly stressed especially in the area of the cutting edges, apart from the torsional and bending forces. In order to ensure sufficient cutting edge hardness with high flexibility and load-bearing capacity, we use high-alloy steels between carbon steel C 60 and chrome-vanadium. The maximum cutting edge hardness is 65 HRC.

For the superior processing of extremely hard or tough materials, we equip a part of our side cutter and diagonal cutter range with carbide cutting edges. These are ideally suitable for cutting through piano wire, nickel wire or diode wire as well as for glass fibre, which are being increasingly used in the electronics and aviation industry.

We achieve perfection of form and no-compromise cutting edge sharpness in the traditional hand-grinding process – an impressive finished look through the subsequent surface treatment or surface finishing. Piece by piece.

anti-slip surface optimizes contact with hand

double leaf spring suspension

box joint giving long and lasting cutting performance without the risk of getting loose

glare-free by gun metal and mirror finish

antistatic derivating, ergonomic handle





The VDE GS symbol

This symbol indicates that the tools so marked have been tested for safety regarding potential hazards from electricity, physical danger, heat, radiation and other hazards. The symbol is equivalent to the German VDE requirements and comparable with harmonised standards in the EU and around the world and confirms that the defined tolerance limits have been adhered to.



Double triangle and voltage range

Markings for insulated tools consisting of the double triangle show their suitability for work on electrical systems that are still “live”. The voltage or voltage range given shows the maximum safe load in volts.

Safety checks to IEC standards using a pair of ELORA pliers as an example

1. Voltage test

ELORA VDE tools are individually tested to 10,000 V AC and are approved for work in systems carrying a live voltage of up to 1,000 V AC or 1,500 V DC.

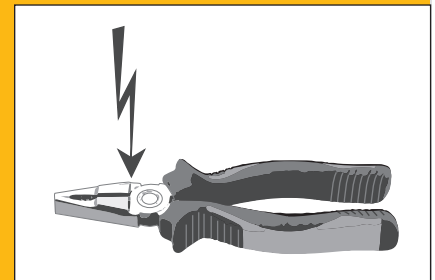

2. Impact test

The insulating material of ELORA VDE tools is subjected to an impact test. At an ambient temperature of +23 °C and after storage for 2 hours at -25 °C, an impact test is performed to see whether the insulation material can withstand jolts and impacts after being subjected to these fluctuations in temperature. The test must not cause any of the insulation to crack, rupture or peel off.

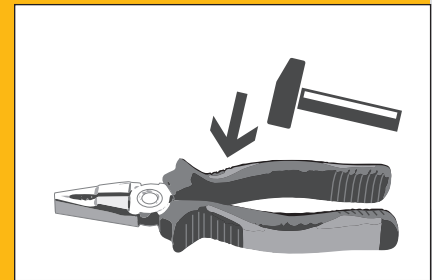

3. Adhesion test

Even under high loads, the insulation material must remain firmly bonded to the tool. First, the tool is stored for 168 hours at a temperature of 70 °C. Then the adhesive strength of the insulation material is subjected to a tensile force of 500 N.

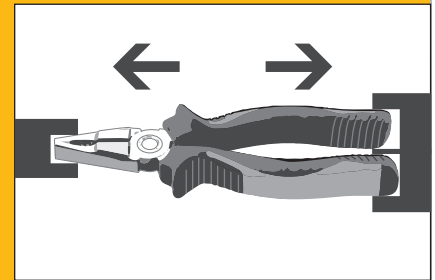

4. Testing resistance to fire

A test flame is aimed at the tool for a duration of 10 seconds. Once the flame is removed, the flame emitted by the insulation must not exceed 120 mm for a period of 20 seconds.

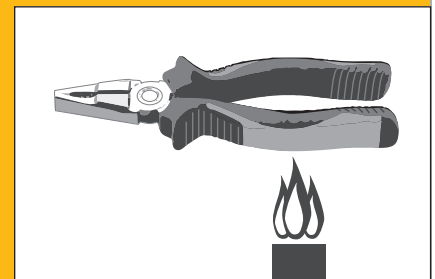

5. Pressure test

After being stored for 2 hours at 70 °C, the insulation material of the ELORA VDE tools is subjected to a compressive force of 20 N and a testing voltage of 5,000 V AC for three minutes. During this time, there must be no disruptive discharge or arcing on the surface or in the air.

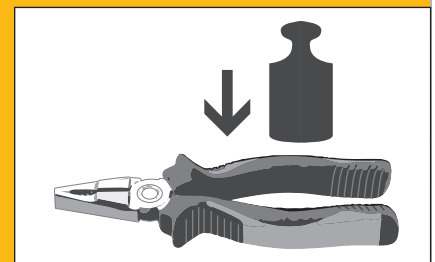

4510

ELECTRONIC SIDE CUTTER ESD

- for cutting in places difficult to access, for work with endangered electronic components
- pointed, narrow head, small version with fine bevel, maximum stability under load of the cutting edges by additional inductive hardening and box joint, with double opening leaf spring, polished and high gloss gunmetal-finish, with 2-C ESD handles, surface resistance 10^6-10^9 Ohm
- cutting edge hardness 61-63 HRC
- ELORA-high grade tool steel C60 / 1.0601
- DIN ISO 9654, ESD: DIN IEC 614340-5-1

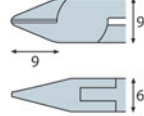

Code	Number	Medium mm / AWG	Soft mm / AWG	l/mm	Pieces	Weight/g
4510010001000	4510-F E 2K	0,8 / 20	1,5 / 15	120	1	91

4520-...

ELECTRONIC SIDE CUTTER ESD

- for all work with electrostatic endangered components
- pointed head, maximum stability under load by additional inductive hardening and box joint, with double opening leaf spring, polished and high gloss gunmetal-finished, with 2-C ESD handles, surface resistance 10^6-10^9 Ohm
- F= with fine bevel
- O= without bevel
- cutting edge hardness 61-63 HRC
- ELORA-high grade tool steel C60 / 1.0601
- DIN ISO 9654, ESD: DIN IEC 614340-5-1

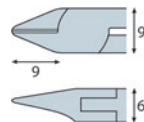

Code	Number	Medium mm / AWG	Soft mm / AWG	l/mm	Pieces	Weight/g
4520010001000	4520-F E 2K	0,8 / 20	1,5 / 15	120	1	91
4520030001000	4520-O E 2K	0,6 / 22	1,5 / 15	120	1	92

4550-...

ELECTRONIC SIDE CUTTER ESD

- for all work with electrostatic endangered components
- pointed head, maximum stability under load by additional inductive hardening and box joint, with double opening leaf spring, polished and high gloss gunmetal-finish, with 2-C ESD handles, surface resistance 10^6-10^9 Ohm
- M= with bevel
- F= with fine bevel
- O= without bevel
- cutting edge hardness 61-63 HRC
- ELORA-high grade tool steel C60 / 1.0601
- DIN ISO 9654, ESD: DIN IEC 614340-5-1

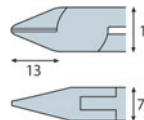

Code	Number	Hard mm / AWG	Medium mm / AWG	Soft mm / AWG	l/mm	Pieces	Weight/g
4550020001000	4550-M E 2K	0,3 / 28	1,0 / 18	1,5 / 15	125	1	96
4550010001000	4550-F E 2K	-	1,0 / 18	1,5 / 15	125	1	95
4550030001000	4550-O E 2K	-	0,8 / 20	1,5 / 15	125	1	95

4760

ELECTRONIC SIDE CUTTER ESD

- for all work with electrostatic endangered components
- pointed head, maximum stability under load by additional inductive hardening and box joint, with double opening leaf spring, polished and high gloss gunmetal-finish, with 2-C ESD handles, surface resistance 10^9-10^9
- cutting edge hardness 61-63 HRC
- ELORA -high grade tool steel C60 / 1.0601
- DIN ISO 9654, ESD: DIN IEC 614340-5-1

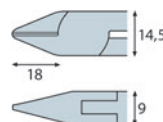

Code	Number	Medium mm / AWG	Soft mm / AWG	l/mm	Pieces	Weight/g
4760010001000	4760-F E 2K	1,5 / 15	2,0 / 12	135	1	143

4530-...

ELECTRONIC SIDE CUTTER ESD

- for all work with electrostatic endangered components
- oval head, maximum stability under load by additional inductive hardening and box joint, with double opening leaf spring, polished and high gloss gunmetal-finish, with 2-C ESD handles, surface resistance 10^6 - 10^9 Ohm
- M= with bevel
- F= with fine bevel
- O= without bevel
- cutting edge hardness 61-63 HRC
- ELORA-high grade tool steel C60 / 1.0601
- DIN ISO 9654, ESD: DIN IEC 614340-5-1

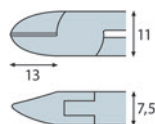

Code	Number	Hard mm / AWG	Medium mm / AWG	Soft mm / AWG	l/mm	Pieces	Weight/g
4530020001000	4530-M E 2K	0,4 / 26	1,0 / 18	1,5 / 15	125	1	98
4530010001000	4530-F E 2K	-	1,0 / 18	1,5 / 15	125	1	95
4530030001000	4530-O E 2K	-	0,8 / 20	1,5 / 15	125	1	98

4540

ELECTRONIC SIDE CUTTER WITH WIRE TRAPPING SPRING ESD

- with trapping wire to cut off wire, for all work with electrostatic endangered components
- oval head with wire trapping spring, with bevel, maximum stability under load by additional inductive hardening and box joint, with double opening leaf spring, polished and high gloss gunmetal-finish, with 2-C ESD handles, surface resistance 10^6 - 10^9 Ohm
- cutting edge hardness 61-63 HRC
- ELORA-high grade tool steel C60 / 1.0601
- DIN ISO 9654, ESD: DIN IEC 614340-5-1

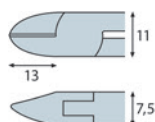

Code	Number	Hard mm / AWG	Medium mm / AWG	Soft mm / AWG	l/mm	Pieces	Weight/g
4540020001000	4540-M E 2K	0,4 / 26	1,0 / 18	1,5 / 15	125	1	96

4730

ELECTRONIC SIDE CUTTER ESD

- for all work with electrostatic endangered components
- oval head, with bevel, maximum stability under load by additional inductive hardening and box joint, with double opening leaf spring, polished and high gloss gunmetal-finish, with 2-C ESD handles, surface resistance 10^6 - 10^9 Ohm
- cutting edge hardness 61-63 HRC
- ELORA-high grade tool steel C60 / 1.0601
- DIN ISO 9654, ESD: DIN IEC 614340-5-1

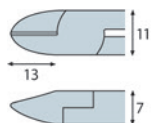

Code	Number	Hard mm / AWG	Medium mm / AWG	Soft mm / AWG	l/mm	Pieces	Weight/g
4730020001000	4730-M E 2K	0,4 / 26	1,0 / 18	1,5 / 15	120	1	101

4560

ELECTRONIC SIDE CUTTER ESD

- for all work with electrostatic endangered components
- oval head, with bevel, maximum stability under load by additional inductive hardening and box joint, with double opening leaf spring, polished and high gloss gunmetal-finish, with 2-C ESD handles, surface resistance 10^6 - 10^9 Ohm
- cutting edge hardness 61-63 HRC
- ELORA-high grade tool steel C60 / 1.0601
- DIN ISO 9654, ESD: DIN IEC 614340-5-1

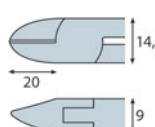

Code	Number	Hard mm / AWG	Medium mm / AWG	Soft mm / AWG	l/mm	Pieces	Weight/g
4560020001000	4560-M E 2K	0,7 / 21	1,5 / 15	2,0 / 12	135	1	155

4620

ELECTRONIC TUNGSTEN CARBIDE SIDE CUTTER ESD

- ▶ for cutting very hard materials with coincident maximum stability under load, for all work with electrostatic endangered components
- ▶ oval head, with bevel, maximum stability under load due to carbide inlay and box joint, with double opening leaf spring, polished and high gloss gunmetal-finish, with 2-C ESD handles, surface resistance 10^8 - 10^9 Ohm
- ▶ cutting edge hardness 84-86 HRA
- ▶ ELORA-Chrome-Vanadium 80 CrV2 / 1.2235 and special carbide metal
- ▶ DIN ISO 9654, ESD: DIN IEC 614340-5-1

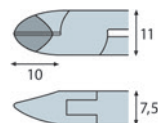

Code	Number	Piano mm / AWG	Hard mm / AWG	Medium mm / AWG	l/mm	Pieces	Weight/g
4620020001000	4620-M E 2K	0,6 / 22	1,0 / 18	2,0 / 12	125	1	98

4640

ELECTRONIC TUNGSTEN CARBIDE OBLIQUE CUTTER ESD

- ▶ for frontal virtually flush cutting of very hard wires, can be used horizontally and vertically for work with electrostatic endangered components
- ▶ straight, compact, solid head, maximum stability under load by carbide inlay and box joint, with double opening leaf spring, polished and high gloss gunmetal-finish, with 2-C ESD handles, surface resistance 10^8 - 10^9 Ohm
- ▶ cutting edge hardness 84-86 HRA
- ▶ ELORA-Chrome-Vanadium 80 CrV2 / 1.2235 and special carbide metal
- ▶ DIN ISO 9654, ESD: DIN IEC 614340-5-1

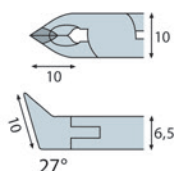

Code	Number	Piano mm / AWG	Hard mm / AWG	Medium mm / AWG	l/mm	Pieces	Weight/g
4640010001000	4640-F E 2K	0,6 / 22	1,0 / 18	2,0 / 12	120	1	93

4630

ELECTRONIC TUNGSTEN CARBIDE SIDE CUTTER ESD

- ▶ for cutting very hard wires which are difficult to access, for all work with electrostatic endangered components
- ▶ pointed, narrow head with groove and fine bevel, small version, maximum stability under load by carbide inlay and box joint, with double opening leaf spring, polished and high gloss gunmetal-finish, with 2-C ESD handles, surface resistance 10^8 - 10^9 Ohm
- ▶ cutting edge hardness 84-86 HRA
- ▶ ELORA-Chrome-Vanadium 80 CrV2 / 1.2235 and special carbide metal
- ▶ DIN ISO 9654, ESD: DIN IEC 614340-5-1

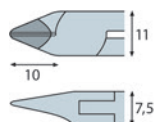

Code	Number	Piano mm / AWG	Hard mm / AWG	Soft mm / AWG	l/mm	Pieces	Weight/g
4630010001000	4630-F E 2K	0,4 / 26	0,8 / 20	1,8 / 13	125	1	99

4590

ELECTRONIC OBLIQUE CUTTER ESD

- ▶ for frontal virtually flush cutting of wires, can be used horizontally and vertically for work with electrostatic endangered components
- ▶ wide head, long cutting edges, with fine bevel, maximum stability under load by additional inductive hardening and box joint, with double opening leaf spring, polished and high gloss gunmetal-finish, with 2-C ESD handles, surface resistance 10^6 - 10^9 Ohm
- ▶ cutting edge hardness 61-63 HRC
- ▶ ELORA-high grade tool steel C60 / 1.0601
- ▶ DIN ISO 9654, ESD: DIN IEC 614340-5-1

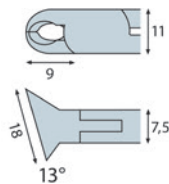

Code	Number	Hard mm / AWG	Medium mm / AWG	Soft mm / AWG	l/mm	Pieces	Weight/g
4590010001000	4590-F E 2K	0,5 / 24	1,2 / 16	1,6 / 14	125	1	126

4580-...

ELECTRONIC OBLIQUE CUTTER ESD

- ▶ for frontal virtually flush cutting of wires, can be used horizontally and vertically for work with electrostatic endangered components
- ▶ straight, compact, solid head, maximum stability under load by additional inductive hardening and box joint, with double opening leaf spring, polished and high gloss gunmetal-finish, with 2-C ESD handles, surface resistance 10^6 - 10^9 Ohm
- ▶ F= with fine bevel
- ▶ O= without bevel
- ▶ cutting edge hardness 61-63 HRC
- ▶ ELORA-high grade tool steel C60 / 1.0601
- ▶ DIN ISO 9654, ESD: DIN IEC 614340-5-1

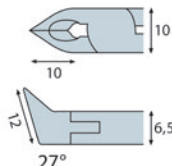

Code	Number	Hard mm / AWG	Medium mm / AWG	Soft mm / AWG	l/mm	Pieces	Weight/g
4580010001000	4580-F E 2K	0,4 / 26	1,0 / 18	1,2 / 16	120	1	94
4580030001000	4580-O E 2K	-	0,8 / 20	1,0 / 18	120	1	94

4570

ELECTRONIC OBLIQUE TIP CUTTER ESD

- ▶ for virtually flush cutting of thin, soft wires in places difficult to access, for work with electrostatic endangered components
- ▶ extra narrow head, fine bevel, maximum stability under load by additional inductive hardening and box joint, with double opening leaf spring, polished and high gloss gunmetal-finish, with 2-C ESD handles, surface resistance 10^6 - 10^9 Ohm
- ▶ cutting edge hardness 61-63 HRC
- ▶ ELORA-Chrome-Vanadium 80CrV2 / 1.2235
- ▶ DIN ISO 9654, ESD: DIN IEC 614340-5-1

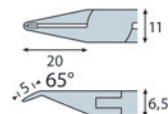

Code	Number	Medium mm / AWG	Soft mm / AWG	l/mm	Pieces	Weight/g
4570010001000	4570-F E 2K	0,6 / 22	0,8 / 20	130	1	96

4770

ELECTRONIC WIRE STRIPPING PLIER ESD

- ▶ for wire stripping of PVC, Teflon etc., for work with electrostatic endangered components
- ▶ brass adjustment screw inside jaws, inlaid joint, with double opening leaf spring, polished and high gloss gunmetal-finish, with 2-C ESD handles, surface resistance 10^6 - 10^9 Ohm
- ▶ ELORA-high grade tool steel C45 / 1.0503
- ▶ ESD: DIN IEC 61340-5-1

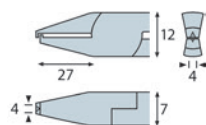

Code	Number	Ø mm	l/mm	Pieces	Weight/g
4770000001000	4770-1 E 2K	0,1 - 0,8	150	1	128

4710-...

ELECTRONIC FLAT NOSE PLIER ESD

- for fine precision gripping and bending work, for work with electrostatic endangered components
- straight, short jaws, flat tips, box joint, with double opening leaf spring, polished and high gloss gunmetal-finish, with 2-C ESD handles, surface resistance 10^6 - 10^9 Ohm
- OH= smooth gripping surface, without cut
- MH= serrated gripping surface, with cut
- ELORA-high grade tool steel C45 / 1.0503
- DIN ISO 9655, ESD: DIN IEC 61340-5-1

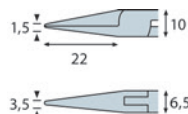

Code	Number	serrated	smooth	l/mm	Pieces	Weight/g
4710050001000	4710-OH E 2K	-	x	130	1	92
4710040001000	4710-MH E 2K	x	-	130	1	95

4740

ELECTRONIC FLAT NOSE PLIER ESD

- for fine precision gripping and bending work, for work with electrostatic endangered components
- straight, long jaws, flat tips, box joint, with double opening leaf spring, polished and high gloss gunmetal-finish, with 2-C ESD handles, surface resistance 10^6 - 10^9 Ohm
- smooth gripping surface
- ELORA-high grade tool steel C45 / 1.0503
- DIN ISO 9655, ESD: DIN IEC 61340-5-1

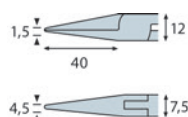

Code	Number	smooth	l/mm	Pieces	Weight/g
4740050001000	4740-OH E 2K	x	150	1	132

4720

ELECTRONIC ROUND NOSE PLIER ESD

- for fine precision gripping and bending work, for work with electrostatic endangered components
- short jaws, round tips, box joint, with double opening leaf spring, polished and high gloss gunmetal-finish, with 2-C ESD handles, surface resistance 10^6 - 10^9 Ohm
- smooth gripping surface
- ELORA-high grade tool steel C45 / 1.0503
- DIN ISO 9655, ESD: DIN IEC 61340-5-1

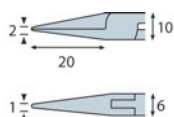

Code	Number	smooth	l/mm	Pieces	Weight/g
4720050001000	4720-OH E 2K	x	130	1	94

4670

ELECTRONIC SNIPE NOSE PLIER ESD

- for fine precision gripping and bending work, for work with electrostatic endangered components
- angled, short jaws, half round tips, box joint, with double opening leaf spring, polished and high gloss gunmetal-finish, with 2-C ESD handles, surface resistance 10^6 - 10^9 Ohm
- smooth gripping surface
- ELORA-high grade tool steel C45 / 1.0503
- DIN ISO 9655, ESD: DIN IEC 61340-5-1

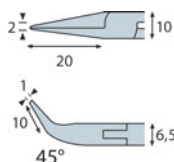

Code	Number	smooth	l/mm	Pieces	Weight/g
4670050001000	4670-OH E 2K	x	130	1	96

4660-...

ELECTRONIC SNIPE NOSE PLIER ESD

- ▶ for fine precision gripping and bending work, for work with electrostatic endangered components
- ▶ short, straight jaws, half round tips, box joint, with double opening leaf spring, polished and high gloss gunmetal-finish, with 2-C ESD handles, surface resistance 10^6-10^9 Ohm
- ▶ OH: smooth gripping surface
- ▶ MH: serrated gripping surface
- ▶ ELORA-high grade tool steel C45 / 1.0503
- ▶ DIN ISO 9655, ESD: DIN IEC 61340-5-1

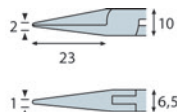

Code	Number	serrated	smooth	l/mm	Pieces	Weight/g
4660050001000	4660-OH E 2K	-	x	130	1	96
4660040001000	4660-MH E 2K	x	-	130	1	97

4680

ELECTRONIC SNIPE NOSE PLIER ESD

- ▶ for fine precision gripping and bending work, for work with electrostatic endangered components
- ▶ long, straight jaws, half round tips, box joint, with double opening leaf spring, polished and high gloss gunmetal-finish, with 2-C ESD handles, surface resistance 10^6-10^9 Ohm
- ▶ serrated gripping surface
- ▶ ELORA-high grade tool steel C45 / 1.0503
- ▶ DIN ISO 9655, ESD: DIN IEC 61340-5-1

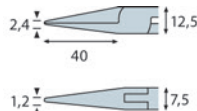

Code	Number	serrated	l/mm	Pieces	Weight/g
4680040001000	4680-MH E 2K	x	155	1	129

4690

ELECTRONIC SNIPE NOSE PLIER ESD

- ▶ for fine precision gripping and bending work, for work with electrostatic endangered components
- ▶ angled, straight long jaws, half round tips, box joint, with double opening leaf spring, polished and high gloss gunmetal-finish, with 2-C ESD handles, surface resistance 10^6-10^9 Ohm
- ▶ serrated gripping surface
- ▶ ELORA-high grade tool steel C45 / 1.0503
- ▶ DIN ISO 9655, ESD: DIN IEC 61340-5-1

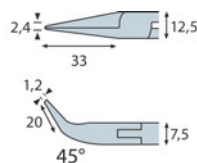

Code	Number	serrated	l/mm	Pieces	Weight/g
4690040001000	4690-MH E 2K	x	155	1	129

4700

ELECTRONIC SNIPE NOSE PLIER ESD

- ▶ for fine precision gripping and bending work, for work with electrostatic endangered components
- ▶ very fine, slim, long, straight jaws, half round tips, box joint, with double opening leaf spring, polished and high gloss gunmetal-finish, with 2-C ESD handles, surface resistance 10^6-10^9 Ohm
- ▶ smooth gripping surface
- ▶ ELORA-high grade tool steel C45 / 1.0503
- ▶ DIN ISO 9655, ESD: DIN IEC 61340-5-1

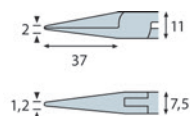

Code	Number	smooth	l/mm	Pieces	Weight/g
4700050001000	4700-OH E 2K	x	150	1	128

You will find more Electronic Side Cutters on page no. 297







600-IS...ESD

ELECTRONIC SCREWDRIVER ESD

- for plain slotted screws
- for work with electrostatic endangered components
- blade through hardened and chrome-plated, tip gunmetal-finish
- ESD precision handle with rotating cap, surface resistance 10^6-10^9 Ohm
- blade made of high quality ELORA-Chrome-Vanadium-Molybdenum steel
- DIN 91953, DIN EN 100-015/1
- ESD: DIN IEC 61340-5-1







Code	Number	Edge mm			Pieces 	Weight/g 
0600086002000	600-IS 0,8x60 ESD	0,2 x 0,8	60	157	6	16
0600126002000	600-IS 1,2x60 ESD	0,2 x 1,2	60	157	6	16
0600156002000	600-IS 1,5x60 ESD	0,25 x 1,5	60	157	6	16
0600186002000	600-IS 1,8x60 ESD	0,3 x 1,8	60	157	6	16
0600256002000	600-IS 2,5x60 ESD	0,4 x 2,5	60	157	6	16
0600257502000	600-IS 2,5x75 ESD	0,4 x 2,5	75	172	6	20
0600301002000	600-IS 3,0x100 ESD	0,5 x 3,0	100	197	6	20
0600301502000	600-IS 3,0x150 ESD	0,5 x 3,0	150	247	6	23
0600302402000	600-IS 3,0x240 ESD	0,5 x 3,0	240	337	6	30
0600401002000	600-IS 4,0x100 ESD	0,8 x 4,0	100	197	6	25
0600401502000	600-IS 4,0x150 ESD	0,8 x 4,0	150	247	6	30
0600452502000	600-IS 4,5x250 ESD	0,8 x 4,5	250	347	6	33

610-PH...ESD

ELECTRONIC SCREWDRIVER ESD

- for cross slotted screws
- for work with electrostatic endangered components
- blade through hardened and chrome-plated, tip gunmetal-finish
- ESD precision handle with rotating cap, surface resistance 10^6-10^9 Ohm
- blade made of high quality ELORA-Chrome-Vanadium-Molybdenum steel
- DIN 91953, DIN EN 100-015/1
- ESD: DIN IEC 61340-5-1







Code	Number			Pieces 	Weight/g 
0610000002002	610-PH 000 ESD	60	157	6	12
0610000002001	610-PH 00 ESD	60	157	6	12
0610000002000	610-PH 0 ESD	60	157	6	13
0610000012000	610-PH 1 ESD	60	157	6	23
0610000012001	610-PH 1x185 ESD	185	282	6	45
0610000012002	610-PH 1x285 ESD	285	382	6	60

625-...ESD

ELECTRONIC SCREWDRIVER ESD

- for inside hexagon screws
- for work with electrostatic endangered components
- blade through hardened and chrome-plated, tip gunmetal-finish
- ESD precision handle with rotating cap, surface resistance 10^6-10^9 Ohm
- blade made of high quality ELORA-Chrome-Vanadium-Molybdenum steel
- DIN 91953, DIN EN 100-015/1
- ESD: DIN IEC 61340-5-1



Code	Number			Pieces 	Weight/g 
0625000072000	625-0,7 ESD	50	147	6	14
0625000092000	625-0,9 ESD	50	147	6	14
0625000132000	625-1,3 ESD	50	147	6	14
0625000152000	625-1,5 ESD	50	147	6	14
0625000202000	625-2,0 ESD	50	147	6	14
0625000252000	625-2,5 ESD	60	157	6	16
0625000302000	625-3,0 ESD	60	157	6	16
0625000352000	625-3,5 ESD	60	157	6	17
0625000402000	625-4,0 ESD	60	157	6	19

625-KU...ESD

ELECTRONIC BALL END SCREWDRIVER ESD

- for inside hexagon screws
- for work with electrostatic endangered components
- blade through hardened and chrome-plated, tip gunmetal-finish
- ESD precision handle with rotating cap, surface resistance 10^6 – 10^9 Ohm
- blade made of high quality ELORA-Chrome-Vanadium-Molybdenum steel
- DIN 91953, DIN EN 100-015/1
- ESD: DIN IEC 61340-5-1



Code	Number	mm	mm	Pieces 	Weight/g
0625000151000	625-KU 1,5 ESD	50	147	6	14
0625000201000	625-KU 2,0 ESD	50	147	6	14
0625000251000	625-KU 2,5 ESD	60	157	6	14
0625000301000	625-KU 3,0 ESD	60	157	6	14

630-...ESD

ELECTRONIC SOCKET SPANNER ESD

- for outside hexagon screws
- for work with electrostatic endangered components
- blade through hardened and chrome-plated, tip gunmetal-finish
- ESD precision handle with rotating cap, surface resistance 10^6 – 10^9 Ohm
- blade made of high quality ELORA-Chrome-Vanadium-Molybdenum steel
- DIN 91953, DIN EN 100-015/1
- ESD: DIN IEC 61340-5-1



Code	Number	mm	mm	Pieces 	Weight/g
0630000252000	630-2,5 ESD	60	157	6	21
0630000302000	630-3,0 ESD	60	157	6	22
0630000322000	630-3,2 ESD	60	157	6	22
0630000352000	630-3,5 ESD	60	157	6	23
0630000402000	630-4,0 ESD	60	157	6	24
0630000452000	630-4,5 ESD	60	157	6	25
0630000502000	630-5,0 ESD	60	157	6	26
0630000552000	630-5,5 ESD	60	157	6	27

620-TTX...ESD

ELECTRONIC SCREWDRIVER ESD

- suitable for smallest inside TORX® screws with locking pin, for work with electrostatic endangered components
- blade through hardened and chrome-plated, tip gunmetal-finish
- ESD precision handle with rotating cap, surface resistance 10^6 – 10^9 Ohm
- blade made of high quality ELORA-Chrome-Vanadium-Molybdenum steel
- DIN 91953, DIN EN 100-015/1
- ESD: DIN IEC 61340-5-1
- TORX® = reg. trade mark of Acument Intellectual Properties, LLC. USA



Code	Number	mm	mm	mm	Pieces 	Weight/g
0620000073000	620-TTX 7 ESD	1,99	50	147	6	13
0620000083000	620-TTX 8 ESD	2,31	60	157	6	13
0620000093000	620-TTX 9 ESD	2,50	60	157	6	13
0620000103000	620-TTX10 ESD	2,74	80	177	6	13
0620000153000	620-TTX15 ESD	3,27	80	177	6	13

620-TX...ESD

ELECTRONIC SCREWDRIVER ESD

- for smallest inside TORX® screws
- for work with electrostatic endangered components
- blade through hardened and chrome-plated, tip gunmetal-finish
- ESD precision handle with rotating cap, surface resistance 10^6 – 10^9 Ohm
- blade made of high quality ELORA-Chrome-Vanadium-Molybdenum steel
- DIN 91953, DIN EN 100-015/1
- ESD: DIN IEC 61340-5-1
- TORX® = reg. trademark of Acument Intellectual Properties, LLC. USA



Code	Number	★ mm	mm	mm	Pieces	Weight/g
0620000012000	620-TX 1 ESD	0,84	50	147	6	13
0620000022000	620-TX 2 ESD	0,94	50	147	6	13
0620000032000	620-TX 3 ESD	1,12	50	147	6	13
0620000042000	620-TX 4 ESD	1,30	50	147	6	13
0620000052000	620-TX 5 ESD	1,42	50	147	6	13
0620000062000	620-TX 6 ESD	1,67	50	147	6	13
0620000072000	620-TX 7 ESD	1,99	50	147	6	13
0620000082000	620-TX 8 ESD	2,31	60	157	6	13
0620000092000	620-TX 9 ESD	2,50	60	157	6	13
0620000102000	620-TX 10 ESD	2,74	80	177	6	13
0620000152000	620-TX 15 ESD	3,27	80	177	6	15
0620000202000	620-TX 20 ESD	3,86	100	197	6	15

07

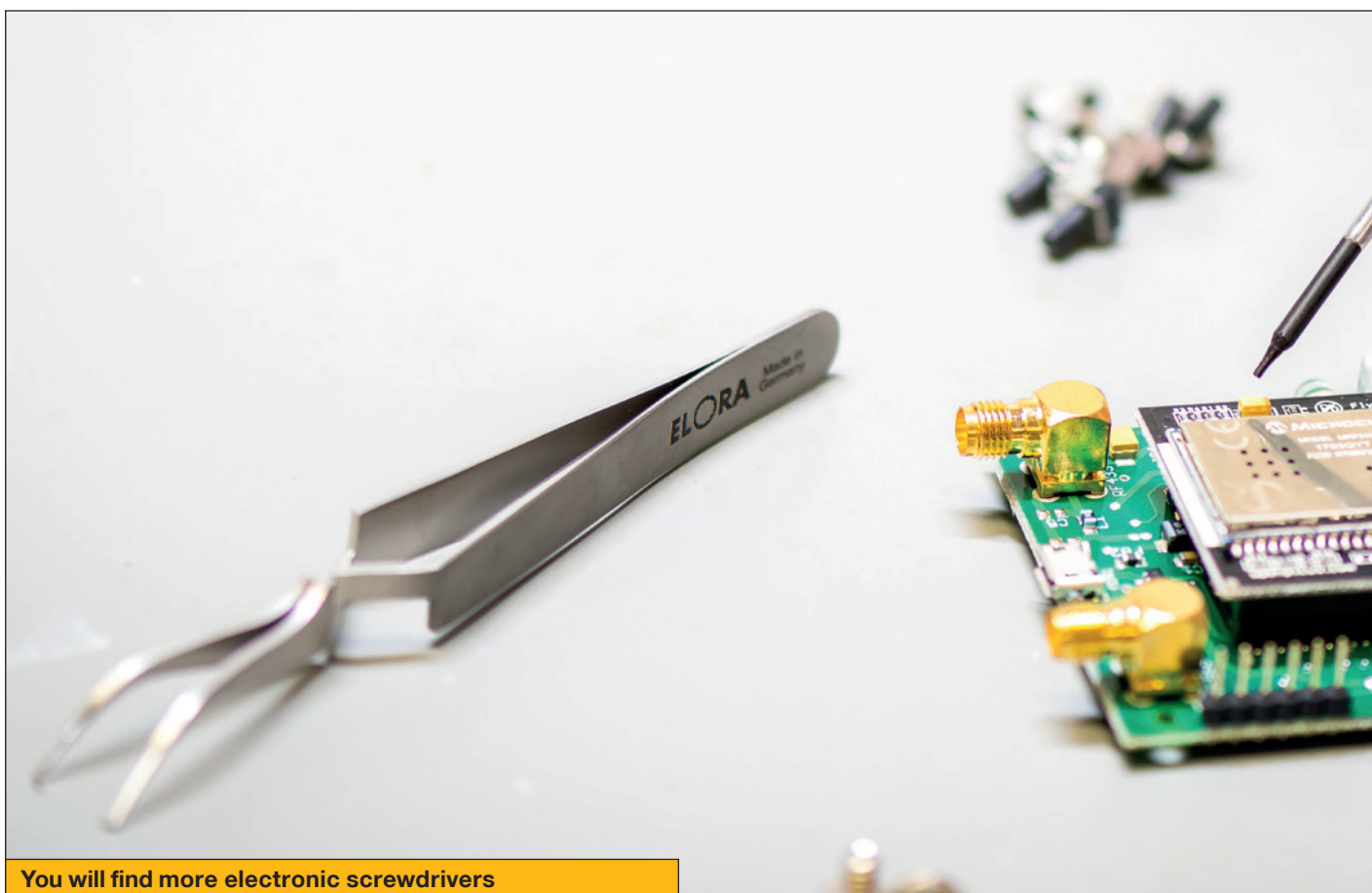

You will find more electronic screwdrivers on page no. 298



5170-STE, 5180-STE, 5190-STE

POSITIONING TWEEZERS ESD

- ▶ for holding, positioning and unsoldering of vertical and horizontal cylindrical devices
- ▶ anti-glare black finish, grooved gripping surfaces, surface resistance 10⁶-10⁹ Ohm
- ▶ stainless, antimagnetic, acid-proof
- ▶ ELORA-Special-Chrome-Nickel-steel
- ▶ ESD: DIN IEC 61340-5-1



Code	Number	Points	l/mm	Pieces	Weight/g
5170000007000	5170-STE	Ø 0,8 mm, oval	120	6	14
5180000007000	5180-STE	Ø 1,5 mm, oval	120	6	14
5190000007000	5190-STE	Ø 1,5 mm oblique, half round	120	6	14

5210-STE

POSITIONING TWEEZERS ESD

- ▶ for all fine gripping and assembly work
- ▶ anti-glare black finish, inside vertical concave, until Ø 2mm, grooved gripping surfaces, surface resistance 10⁶-10⁹ Ohm
- ▶ stainless, antimagnetic, acid-proof
- ▶ ELORA-Special-Chrome-Nickel-steel
- ▶ ESD: DIN IEC 61340-5-1



Code	Number	l/mm	Pieces	Weight/g
5210000007000	5210-STE	120	6	14

5160-STE, 5240-STE

ELECTRONIC TWEEZERS ESD

- ▶ for all fine gripping and assembly work
- ▶ anti-glare black finish, smooth gripping and grab surfaces, extremely fine, straight tips, surface resistance 10⁶-10⁹ Ohm
- ▶ stainless, antimagnetic, acid-proof
- ▶ ELORA-Special-Chrome-Nickel-steel
- ▶ ESD: DIN IEC 61340-5-1



Code	Number	l/mm	Pieces	Weight/g
5160000007000	5160-STE	120	6	14
5240000007000	5240-STE	140	6	20

5260-STE, 5280-STE

ELECTRONIC TWEEZERS ESD

- ▶ for all fine gripping and assembly work
- ▶ anti-glare black finish, smooth gripping and grab surfaces, surface resistance 10⁶-10⁹ Ohm
- ▶ stainless, antimagnetic, acid-proof
- ▶ ELORA-Special-Chrome-Nickel-steel
- ▶ ESD: DIN IEC 61340-5-1



Code	Number	Points	l/mm	Pieces	Weight/g
5260000007000	5260-STE	curved, extremely fine	122	6	20
5280000007000	5280-STE	double curved and bent, extremely fine	122	6	20

5330-STE, 5340-STE

ELECTRONIC TWEEZERS ESD

- for all fine gripping and assembly work
- satin antiglare black finish, smooth gripping surfaces, surface resistance 10^6 - 10^9 Ohm, antimagnetic, acid-proof, stainless
- ELORA-Special-Chrome-Nickel-steel
- ESD: DIN IEC 61340-5-1



Code	Number	Points	l/mm	Pieces	Weight/g
5330000007000	5330-STE	bent, extreme fine	108	6	12
5340000007000	5340-STE	straight, extreme fine	108	6	12

5350-STE

ELECTRONIC TWEEZERS ESD

- for all fine gripping and assembly work
- anti-glare black finish, smooth gripping and grab surfaces, flat, extremely long, fine tips, surface resistance 10^6 - 10^9 Ohm
- stainless, antimagnetic, acid-proof
- ELORA-Special-Chrome-Nickel-steel
- ESD: DIN IEC 61340-5-1



Code	Number	l/mm	Pieces	Weight/g
5350000007000	5350-STE	130	6	20

07

600-S15

ESD-SET

- 15 pcs.
- in black plastic box with 2-colour foam material
- TORX® = reg. trade mark of Acument Intellectual Properties, LLC. USA



Code	Number	Contents	Pieces	Weight/g
0600500151000	600-S15	Electronic Side Cutter, ESD 4560-ME 2K, 4530-OE 2K Electronic Flat Nose Plier, ESD 4710-OH E 2K Electronic Snipe Nose Plier, ESD 4660-OH E 2K Electronic Screwdriver, ESD 600-IS 0,8x60, 1,5x60, 2,5x60 Electronic Screwdriver, ESD 610-PH 000x60, 00x60, 0x60 Electronic Screwdriver for TORX®-Screws, ESD 620-TX 5, 6, 7 Electronic Tweezers, ESD 5330-STE, 5340-STE	1	2100

432

ELECTRONIC SIDE CUTTER

- oval head, lap joint, with double leaf spring
- with dip insulated PVC handles
- gunmetal-finish, polished head
- ELORA-high grade tool steel C60 / 1.0601



Code	Number	Art.-Indication	l/mm	Pieces	Weight/g
0432000000000	432	with bevel edge	110	1	83

435

ELECTRONIC SIDE CUTTER

- pointed head, lap joint, with double leaf spring
- with dip insulated PVC handles
- gunmetal-finish, polished head
- ELORA-high grade tool steel C60 / 1.0601



Code	Number	Art.-Indication	l/mm	Pieces	Weight/g
0435000000000	435	with bevel edge	110	1	83

07

You will find ESD-pliers and -side cutters on page no. 286-291







600-IS...

ELECTRONIC SCREWDRIVER

- for plain slotted screws
- dull chrome plated blade with additionally coated blade tip
- 2 component grip, revolving end-cap, non-slip micro-surface
- blade made of ELORA-Chrome-Vanadium-Molybdenum steel 73MoV5 / 1.2381







Code	Number	Edge mm			Pieces 	Weight/g 
0600012601000	600-IS 1,2x60	0,25 x 1,2	60	153	6	11
0600015601000	600-IS 1,5x60	0,23 x 1,5	60	153	6	11
0600018601000	600-IS 1,8x60	0,3 x 1,8	60	153	6	11
0600020601000	600-IS 2,0x60	0,4 x 2,0	60	153	6	11
0600025751000	600-IS 2,5x75	0,4 x 2,5	75	168	6	11
0600030101000	600-IS 3,0x100	0,5 x 3,0	100	193	6	16
0600030151000	600-IS 3,0x150	0,5 x 3,0	150	243	6	19
0600035101000	600-IS 3,5x100	0,6 x 3,5	100	193	6	20
0600040101000	600-IS 4,0x100	0,8 x 4,0	100	193	6	24
0600040151000	600-IS 4,0x150	0,8 x 4,0	150	243	6	31

610-PH...

ELECTRONIC SCREWDRIVER

- for cross slotted screws
- dull chrome plated blade with grey tip
- 2-C handle with revolving end-cap, non-slip resistant micro-surface
- blade made of ELORA-Chrome-Vanadium-Molybdenum steel 75MoV5 / 1.2381







Code	Number			Pieces 	Weight/g 
0610000001003	610-PH 000	60	153	6	12
0610000001002	610-PH 00	60	153	6	12
0610000001000	610-PH 0	60	153	6	13
0610000011000	610-PH 1	80	173	6	23

612-PZ...

ELECTRONIC SCREWDRIVER

- for cross slotted screws
- dull chrome plated blade with additionally coated blade tip
- 2 component grip, revolving end-cap, non-slip micro-surface
- blade made of ELORA-Chrome-Vanadium-Molybdenum steel 73MoV5 / 1.2381







Code	Number			Pieces 	Weight/g 
0612000001000	612-PZ 0	60	153	6	13
0612000011000	612-PZ 1	80	173	6	23

620-TX...

ELECTRONIC SCREWDRIVER

- for inside TORX® screws
- dull chrome plated blade with additionally coated blade tip
- 2 component grip, revolving end-cap, non-slip micro-surface
- blade made of Chrome-Vanadium-Molybdenum steel 73MoV5 / 1.2381
- TORX® = reg. trademark of Acument Intellectual Properties, LLC. USA



Code	Number				Pieces 	Weight/g 
0620000051000	620-TX 5	1,42	60	153	6	13
0620000061000	620-TX 6	1,67	60	153	6	13
0620000071000	620-TX 7	1,99	60	153	6	13
0620000081000	620-TX 8	2,31	60	153	6	13
0620000091000	620-TX 9	2,5	60	153	6	13
0620000101000	620-TX 10	2,74	60	153	6	13
0620000151000	620-TX 15	3,27	60	153	6	15
0620000201000	620-TX 20	3,86	80	173	6	22

616-S6

ELECTRONIC SCREWDRIVER SET

- 6 pcs.
- in plastic box
- dull chrome plated blade with additionally coated blade tip
- 2 component grip, revolving end-cap, non-slip micro-surface
- blade made of ELORA-Chrome-Vanadium-Molybdenum steel 73MoV5 / 1.2381



Code	Number	Contents	Pieces	Weight/g
0616500601000	616-S6	Electronic Screwdriver 600-IS 1,5x60, 1,8x60, 2,5x75, 3,0x100 610-PH 0x60, 00x60	1	299

617-S6

ELECTRONIC SCREWDRIVER SET

- 6 pcs.
- in plastic box
- dull chrome plated blade with additionally coated blade tip
- 2 component grip, revolving end-cap, non-slip micro-surface
- blade made of ELORA-Chrome-Vanadium-Molybdenum steel 73MoV5 / 1.2381

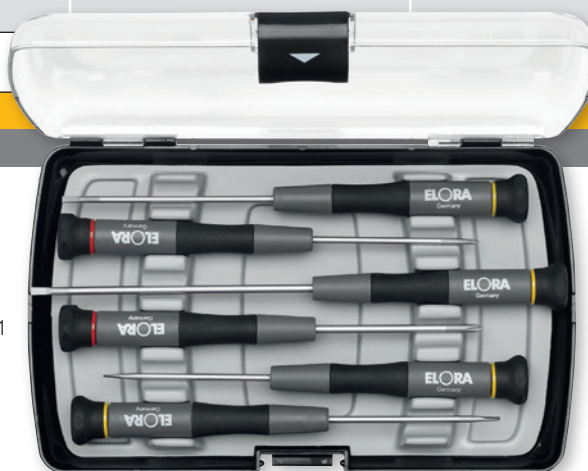

Code	Number	Contents	Pieces	Weight/g
0617500601000	617-S6	Electronic Screwdriver 600-IS 2,5x75, 3,0x100, 4,0x100 610-PH 0x60, 00x60, 1x80	1	325

618-S6

ELECTRONIC SCREWDRIVER SET

- 6 pcs.
- in plastic box
- dull chrome plated blade with additionally coated blade tip
- 2 component grip, revolving end-cap, non-slip micro-surface
- blade made of ELORA-Chrome-Vanadium-Molybdenum steel 73MoV5 / 1.2381
- TORX® = reg. trademark of Acument Intellectual Properties, LLC. USA

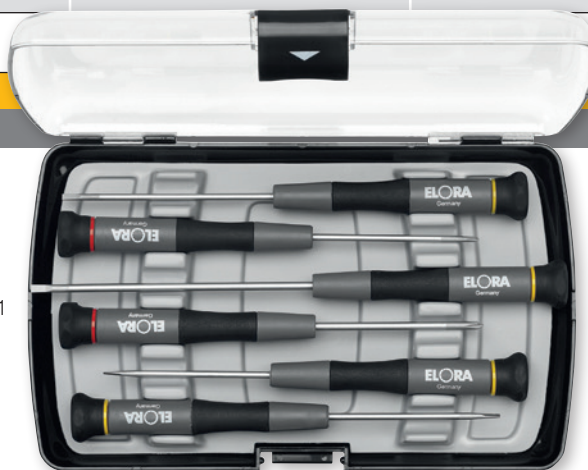

Code	Number	Contents	Pieces	Weight/g
0618500601000	618-S6	Electronic Screwdriver 620-TX 6x60, 7x60, 8x60, 9x60, 10x60, 15x60	1	305

You will find the fitting (De-)Magnetizer on page no. 271



You will find ESD-electronic-screwdrivers on page no. 292-294



5170-ST, 5180-ST, 5190-ST

ELECTRONIC POSITIONING TWEEZERS

- for holding, positioning and unsoldering of vertical and horizontal cylindrical devices
- anti-glare satin finish, grooved gripping surfaces
- stainless, anti-magnetic, acid-proof
- ELORA-Special-Chrome-Nickel-steel



Code	Number	Points	l/mm	Pieces	Weight/g
5170000001000	5170-ST	Ø 0,8 mm, oval	120	6	14
5180000001000	5180-ST	Ø 1,5 mm, oval	120	6	14
5190000001000	5190-ST	Ø 1,5 mm oblique, half round	120	6	14

5110-ST, 5130-ST

ELECTRONIC POSITIONING TWEEZERS

- for holding, positioning and unsoldering of vertical and horizontal cylindrical devices
- anti-glare satin finish, grooved gripping surfaces
- stainless, anti-magnetic, acid-proof
- ELORA-Special-Chrome-Nickel-steel



Code	Number	Points	l/mm	Pieces	Weight/g
5110000001000	5110-ST	Ø 5 mm, inside round	145	6	28
5130000001000	5130-ST	Ø 5 mm oblique, half round	145	6	28

5210-ST

ELECTRONIC POSITIONING TWEEZERS

- for all fine gripping and assembly work
- anti-glare satin finish, inside vertical concave, until Ø 2mm, grooved gripping surfaces
- stainless, antimagnetic, acid-proof
- ELORA-Special-Chrome-Nickel-steel



Code	Number	l/mm	Pieces	Weight/g
5210000001000	5210-ST	120	6	24

5120-ST

ELECTRONIC POSITIONING TWEEZERS

- for all fine gripping and assembly work
- for holding, positioning and unsoldering of vertical and horizontal cylindrical devices
- anti-glare satin finish, tips angled 90°, grooved gripping surfaces
- stainless, anti-magnetic, acid-proof
- ELORA-Special-Chrome-Nickel-steel



Code	Number	l/mm	Pieces	Weight/g
5120000001000	5120-ST	145	6	28

5160-ST, 5240-ST

ELECTRONIC POSITIONING TWEEZERS

- for all fine gripping and assembly work
- anti-glare satin finish, extremely fine, straight tips, grooved gripping and grab surfaces
- stainless, antimagnetic, acid-proof
- ELORA-Special-Chrome-Nickel-steel



Code	Number	l/mm	Pieces	Weight/g
5160000001000	5160-ST	120	6	16
5240000001000	5240-ST	140	6	20

5260-ST, 5270-ST, 5280-ST

ELECTRONIC TWEEZERS

- for all fine gripping and assembly work
- anti-glare satin finish, grooved gripping surfaces
- stainless, antimagnetic, acid-proof
- ELORA-Special-Chrome-Nickel-steel



Code	Number	Points	l/mm	Pieces	Weight/g
5260000001000	5260-ST	curved, extremely fine	122	6	20
5270000001000	5270-ST	curved and bent, extremely fine	122	6	20
5280000001000	5280-ST	curved and bent, extremely fine, counter bending	122	6	20

5330-ST, 5340-ST

ELECTRONIC TWEEZERS

- for all fine gripping and assembly work
- anti-glare satin finish, grooved gripping surfaces
- stainless, antimagnetic, acid-proof
- ELORA-Special-Chrome-Nickel-steel



Code	Number	Points	l/mm	Pieces	Weight/g
5330000001000	5330-ST	curved, extremely fine	108	6	12
5340000001000	5340-ST	straight, extremely fine	108	6	12

5350-ST

ELECTRONIC TWEEZERS

- for all fine gripping and assembly work
- anti-glare satin finish, smooth gripping surfaces, flat, extreme fine, long tips
- stainless, antimagnetic, acid-proof
- ELORA-Special-Chrome-Nickel-steel



Code	Number	l/mm	Pieces	Weight/g
5350000001000	5350-ST	130	6	20

5250

ELECTRONIC TWEEZERS

- for all fine gripping and assembly work
- anti-glare satin finish, rectangular, smooth gripping and grab surfaces, 2 mm width
- stainless, antimagnetic, acid-proof
- ELORA-Special-Chrome-Nickel-steel



Code	Number	l/mm	Pieces	Weight/g
5250000000000	5250	122	6	14

5200-ST

ELECTRONIC IC-TWEEZERS

- for all fine gripping and assembly work
- anti-glare satin finish, grooved gripping surfaces, with IC-tip
- stainless, antimagnetic, acid-proof
- ELORA-Special-Chrome-Nickel-Stainless steel



Code	Number	l/mm	Pieces	Weight/g
5200000001000	5200-ST	120	6	14

5220-ST, 5290-ST, 5300-ST

ELECTRONIC GRIPPING TWEEZERS

- for all fine gripping and assembly work
- anti-glare satin finish, grooved gripping surfaces
- stainless, antimagnetic, acid-proof
- Special-Chrome-Nickel-steel



Code	Number	Surfaces	l/mm	Pieces	Weight/g
5220000001000	5220-ST	rectangular, smooth reaching, 5 mm wide points	120	6	14
5290000001000	5290-ST	rectangular, smooth reaching, 5 mm wide points	145	6	28
5300000001000	5300-ST	rectangular, smooth reaching, 5 mm wide points, red PVC coated	145	6	28

5370-ST

ELECTRONIC SMD REVERSE ACTION TWEEZERS

- for handling of SMD's on PCB's, SOT packages and monolithic chips
- anti-glare satin finish, smooth gripping surfaces
- stainless, antimagnetic, acid-proof
- ELORA-Special-Chrome-Nickel-Stainless steel



Code	Number	l/mm	Pieces	Weight/g
5370000000000	5370-ST	115	6	12

5140-ST, 5150-ST, 5360-ST

UNIVERSAL TWEEZERS

- for all fine gripping and assembly work
- anti-glare satin finish, grooved gripping surface, serrated reaching surface
- serrated grab surfaces, stainless, antimagnetic, acid-proof
- ELORA-Special-Chrome-Nickel-steel



Code	Number	Points	l/mm	Pieces	Weight/g
5140000001000	5140-ST	straight, serrated inside, rounded, 3 mm wide	120	6	14
5150000001000	5150-ST	straight, serrated inside, rounded, 3 mm wide	145	6	24
5360000001000	5360-ST	small and round 2,5 mm, inside serrated, long handle	140	6	20

5310-ST, 5320-ST

UNIVERSAL TWEEZERS

- for all fine gripping and assembly work
- anti-glare satin finish, grooved gripping surfaces, serrated reaching surface
- stainless, antimagnetic, acid-proof
- Special-Chrome-Nickel-steel



Code	Number	Points	l/mm	Pieces	Weight/g
5310000001000	5310-ST	point end, bent, fine serrated inside, with guide pin	155	6	18
5320000001000	5320-ST	point end, straight, fine serrated inside, with guide pin	155	6	18

You will find the fitting (De-)Magnetizer on page no. 271



You will find ESD-tweezers on page no. 295-296



1095

WIRE STRIPPER

- for wire cross section 0,5-6,0 mm²
- for automatic stripping of inner conductors
- with scale for stripping length from 5-12 mm
- integrated side cutter
- blades made of hardened special steel
- black plastic handles



Code	Number	l/mm	Pieces	Weight/g
1095000000000	1095	150	1	112

1094

AUTOMATIC WIRE STRIPPER

- for wire diameter 0,2-6,0 mm²
- automatic adjustment to wire diameter
- with length stop for stripping length from 5-12 mm
- integrated side cutter for wire up to Ø 2,0 mm
- blades made of hardened special steel
- black plastic handles



Code	Number	l/mm	Pieces	Weight/g
1094000000000	1094	200	1	126

1080, 1081, 1082

UNIVERSAL CABLE KNIFE

- 1080-1081: for wire of 4-28 mm Ø
- 1082: for wire of 8-28 mm Ø
- for precise, quick and safe stripping of all kind of round wires, round and length cut in one operation
- blade with transparent plastic safety cover
- hardened special purpose steel blade, black plastic handle



Code	Number	Blade	l/mm	Pieces	Weight/g
1080000000000	1080	dual blade, straight and hook pattern	170	1	80
1081000000000	1081	single blade, straight	170	1	80
1082000000000	1082	inside blade	130	1	70

You will find more wire stripping pliers on page no. 312



You will find ESD-electronic-wire stripping pliers on page no. 289



1083

ROUND WIRE STRIPPER

- for round wire of 8-13 mm Ø (e.g. NYM 3 x 1,5 mm² up to 5x2,5 mm²)
- for flush cutting-off even in difficult to access areas like for example distribution boxes
- automatic adjustment of the cutting depth
- hardened special purpose steel blades, black plastic handle



Code	Number	l/mm	Pieces	Weight/g
1083000000000	1083	128	1	44

281-KZ

CABLE KNIFE

- two-parts, with blade and awl, retractable
- blade 65 mm, awl 70 mm
- blade hardness 54-56 HRC
- with wooden handle
- spring steel C67 / 1.0603



Code	Number	l/mm	Pieces	Weight/g
0281000021000	281-KZ	165	6	83

281

CABLE KNIFE

- folding blade
- blade length 90 mm
- blade hardness 54-56 HRC
- with wooden handle
- spring steel C67 / 1.0603



Code	Number	l/mm	Pieces	Weight/g
0281000000000	281	200	6	74

You will find VDE-electronic-wire stripping pliers on page no. 316



496

WIRE SNIP

- for copper-, steel-, and aluminium wire
- maximum wire cross section 16 mm²
- polished head
- black dip insulated handles
- ELORA-Chrome-Vanadium special purpose steel



Code	Number	l/mm	l/Inch	Pieces	Weight/g
0496000003000	496	210	8,5	1	361

498-7

WIRE SNIP

- for wires up to 10 mm Ø
- self-opening, one hand locking function
- with red, impact resistant plastic handles
- stainless steel



Code	Number	l/mm	l/Inch	Pieces	Weight/g
0498000076000	498-7	160	6,25	1	120

You will find VDE-snips on page no. 316



467-...

CRIMPING PLIER

- for Western plugs
- for cutting and stripping of flat, unshielded cables by one operation
- high crimping quality due to integrated locking (self-releasing mechanism)
- additional stripping function for round wires
- hardened, gunmetal-finish, yellow plastic handles
- ELORA-Chrome-Vanadium special purpose steel



Code	Number	Art.-Indication	l/mm	Pieces	Weight/g
0467000012000	467-1	for crimping 8P8C/RJ-45, 6P6C/RJ-12, 6P4C/RJ-11, 6P2C/RJ-11	190	1	363
0467000022000	467-2	for crimping 8P8C/RJ-45, 6P6C/RJ-12, 6P4C/RJ-11, 4P4C & 4P2C	190	1	384
0467000017000	467-E1	Spare blade for 467-1	15	1	1
0467000027000	467-E2	Spare blade for 467-2	15	1	1

466A-...

CABLE END SLEEVE PLIER

- for pressing of end-sleeves according to DIN 46228 part 1 and 4
- with side cutter and wire stripping mechanism for soft wire
- red handles, PVC dip insulated
- ELORA-high grade steel C45 / 1.0503



Code	Number	for cable terminals Ø mm	l/mm	Pieces	Weight/g
0466000255100	466A-2,5	0,25-2,5	155	1	198
0466001605100	466A-16,0	0,50-16,0	220	1	310

466I-...

CABLE END SLEEVES

- tin-plated pattern
- deoxidized copper, (SF-Cu) according to DIN 1787
- DIN 46228, part 1
- sales unit 1000 pcs.



Code	Number	Section mm ²	l/mm	Pieces	Weight/g
0466010051000	466I-0,5	0,5	6	1	36
0466010071000	466I-0,75	0,75	6	1	39
0466010101000	466I-1,0	1,0	6	1	42
0466010151000	466I-1,5	1,5	7	1	60
0466010251000	466I-2,5	2,5	7	1	78

466IH-...

CABLE END SLEEVES

- ▶ tin-plated pattern, insulated by plastic collar
- ▶ heat resistant up to 110 C°
- ▶ copper (E-Cu) according to DIN 1787
- ▶ DIN 46228, part 4
- ▶ sales unit 500 pcs.



Code	Number	Section mm ²	l/mm	Pieces	Weight/g
0466020051000	466IH-0,5	0,5	8	1	40
0466020071000	466IH-0,75	0,75	8	1	43
0466020101000	466IH-1,0	1,0	8	1	51
0466020151000	466IH-1,5	1,5	8	1	55
0466020251000	466IH-2,5	2,5	8	1	87

466S-...

CABLE END SLEEVES ASSORTMENT

- ▶ in transparent plastic box
- ▶ according to DIN 46228



Code	Number	Contents	Pieces	Weight/g
0466500105100	466S-1	Cable End Sleeves 500x 466I-0,25 500x 466I-0,34 500x 466I-0,5 500x 466I-0,75 500x 466I-1,0	1	159
0466500255100	466S-2,5	Cable End Sleeves 500x 466I-0,5 500x 466I-0,75 400x 466I-1,0 300x 466I-1,5 200x 466I-2,5	1	162
0466500405100	466S-4,0	Cable End Sleeves 400x 466I-0,75 300x 466I-1,0 200x 466I-1,5 150x 466I-2,5 100x 466I-4,0	1	173
0466501605100	466S-16,0	Cable End Sleeves 150x 466I-4,0 75x 466I-6,0 75x 466I-10,0 50x 466I-16,0	1	178
0466510255100	466SH-2,5	Cable End Sleeves insulated 50x 466IH-0,5 100x 466IH-0,75 100x 466IH-1,0 100x 466IH-1,5 50x 466IH-2,5	1	96
0466511605100	466SH-16,0	Cable End Sleeves insulated 50x 466IH-4,0 20x 466IH-6,0 20x 466IH-10,0 10x 466IH-16,0	1	127

466S 210, 466S 309

CABLE END SLEEVES ASSORTMENT

- in transparent plastic box
- for pressing of end-sleeves according to DIN 46228 part 1 and 4
- with side cutter and wire stripping mechanism for soft wire
- red handles, PVC dip insulated
- ELORA-high grade steel C45 / 1.0503



Code	Number	Contents	Pieces	Weight/g
0466502105100	466S 210	Crimping Plier 466A-2,5 VDE-Screwdriver 900IS-100 Cable end sleeves 30 pcs. each 466I-0,25, 0,34, 0,5, 0,75, 1,0, 1,5, 2,5	1	442
0466503095100	466S 309	Crimping Plier 466A-16,0 VDE-Screwdriver 900IS-100 Cable end sleeves 50 pcs. each 466I-0,5, 0,75, 1,0, 1,5 40x 466I-2,5 25x 466I-4,0 20x 466I-6,0 12 pcs. each 466I-10,0, 16,0	1	608

564N

VDE-VOLTAGE TESTER, TWO-POLE

- to detect AC voltage between 6V-1000V and DC voltage between 6V-1400V
- optical, audible and vibration alert if life-threatening voltage occurs starting from 35V
- polarity phase indication at DC
- automatic selection of measurement range, 1 pole single phase detection, two-pole 3 phase control
- continuity test 0-200 kOhm (optical and audible)
- Diode test
- FI/RCD-control test (30mA) via two feelers
- white LED metering monitor light
- easily operated click system to adjust the power socket size
- optimum one-hand operation
- special tips also fit to WAGO-clamps
- unscrewable 4 mm test tip adapter and GS 38 test attachments
- non-volatile test tip covers
- black rubber grips
- dust- and water-jet-proof
- CAT IV 1000V according to IEC/EN 61243-3:2014 (DIN VDE 0682-401)
- WAGO= reg. Trademark of company WAGO Kontakttechnik GmbH & Co. KG, Minden / Germany

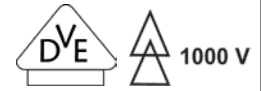

Code	Number	l/mm	Pieces	Weight/g
0564000102100	564N	300	1	408

566-...

VDE VOLTAGE TESTER

- for 100-250V AC
- contact sensor for activating test function
- with plastic clip and pin hole
- zincked blade
- according to DIN VDE 0680 Teil 6 1977-02



Code	Number	l/mm	Pieces	Weight/g
0566001500000	566-150	150	6	30
0566001900000	566-190	190	6	40

561

VOLTAGE TESTER

- for 120-230V AC
- contact sensor in plastic head for activating test function
- transparent plastic handle with lens and red plastic head
- nickel-plated blade and plastic sheathed



Code	Number	Edge mm	l/mm	Pieces	Weight/g
0561000000000	561	0,3x3	65	6	15

563

VOLTAGE TESTER

- for 120-230V AC
- contact sensor in brass head for activating test function
- transparent plastic handle with lens and brass head
- nickel-plated blade and plastic sheathed







Code	Number	Edge mm	l/mm	Pieces	Weight/g
0563000000000	563	0,5x3,5	100	6	34

900IS-...

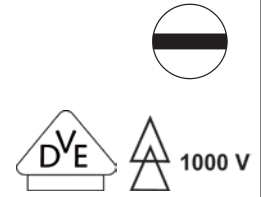
VDE SCREWDRIVER

- for plain slotted screws
- blade gunmetal-finish
- impact resistant handle with suspension hole
- up to ELORA-No. 900IS-100 ELORA-Chrome-Vanadium 73MoV52 / 1.2381 else ELORA-Chrome-Vanadium 59CrV4 / 1.2242
- VDE insulated up to 1.000V, according to EN 60900/IEC 60900, fully insulated blade
- blade according to DIN ISO 2380-1







Code	Number	Edge mm	 mm	 mm	Pieces 	Weight/g 
0900004252100	900IS-75	0,4 x 2,5	75	150	6	31
0900005302100	900IS-100	0,5x 3,0	100	175	6	37
0900008552100	900IS-12508	0,8 x 5,5	125	220	6	84
0900006352100	900IS-106	0,6 x 3,5	100	175	6	38
0900008402100	900IS-108	0,8 x 4,0	100	175	6	42
0900006282100	900IS-7506	0,6 x 2,8	75	150	6	32
0900010552100	900IS-12510	1,0 x 5,5	125	210	6	84
0900012652100	900IS-150	1,2 x 6,5	150	245	6	104
0900012802100	900IS-175	1,2 x 8,0	175	280	6	160
0900016102100	900IS-200	1,6 x 10,0	200	325	6	270

910PH-...

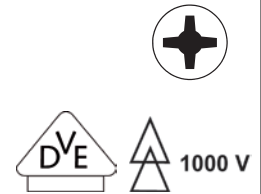
VDE SCREWDRIVER

- for cross slotted screws
- blade gunmetal-finish
- impact resistant handle with suspension hole
- up to ELORA-No. 910PH-0 ELORA-Chrome-Vanadium 73MoV52 / 1.2381, otherwise ELORA-Chrome-Vanadium 59CrV4 / 1.2242
- VDE insulated up to 1.000V, according to EN 60900/IEC 60900, fully insulated blade
- tip according to DIN ISO 8764-1 PH







Code	Number	Number	 mm	 mm	Pieces 	Weight/g 
0910000002100	910PH-0	PH-0	60	140	6	32
0910000012100	910PH-1	PH-1	80	170	6	52
0910000022100	910PH-2	PH-2	100	200	6	86
0910000032100	910PH-3	PH-3	140	255	6	150
0910000042100	910PH-4	PH-4	200	325	6	275

912PZ-...

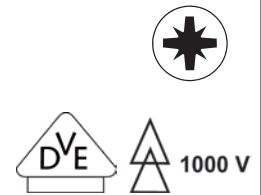
VDE SCREWDRIVER

- for cross slotted screws
- blade gunmetal-finish
- impact resistant handle with suspension hole
- ELORA-Chrome-Vanadium 73MoV52 / 1.2381
- VDE insulated up to 1.000V, according to EN 60900/IEC 60900, fully insulated blade
- tip according to DIN ISO 8764-1 PZ



Code	Number	 mm	 mm	Pieces 	Weight/g 
0912000002100	912PZ-0	60	140	6	32
0912000012100	912PZ-1	80	170	6	52
0912000022100	912PZ-2	100	200	6	86
0912000032100	912PZ-3	140	255	6	150
0912000042100	912PZ-4	200	325	6	275

07

959-L...

HEXAGON KEY

- for inside hexagon screws
- nickel-plated
- ELORA-Chrome-Vanadium steel
- DIN ISO 2936
- 2-color-multilayer insulation (yellow, red) for easy identification of insulation damages
- insulated, tested according to EN/IEC 60900, individually tested with 10.000V and approved for 1.000V

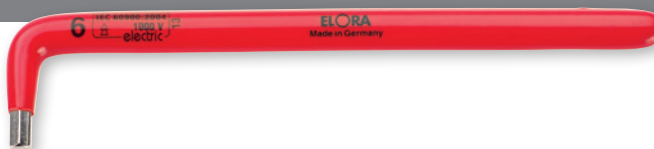

Code	Number	mm	l/mm	Pieces	Weight/g
0959010032100	959-L3	3	130	6	20
0959010042100	959-L4	4	140	6	30
0959010052100	959-L5	5	160	6	50
0959010062100	959-L6	6	180	6	80
0959010082100	959-L8	8	200	6	140
0959010102100	959-L10	10	225	6	230
0959010122100	959-L12	12	250	6	245

956-...

HEXAGON KEY WITH T-HANDLE

- for inside hexagon screws
- nickel-plated
- ELORA-Chrome-Vanadium steel
- DIN ISO 2936
- insulated, tested according to EN/IEC 60900, individually tested with 10.000V and approved for 1.000V



Code	Number	mm	l/mm	Pieces	Weight/g
0956000042100	956-4	4	200	6	87
0956000052100	956-5	5	200	6	93
0956000062100	956-6	6	200	6	110
0956000082100	956-8	8	200	6	128

979S-5K

VDE SCREWDRIVER SET

- 5 pcs.
- in an environmentally friendly carton package



Code	Number	Contents	Pieces	Weight/g
0979500509000	979 S-5K	VDE-Screwdrivers for plain 900-IS 75, 106, 12508 Cross slotted VDE-Screwdrivers 910-PH 1, PH 2	1	358

You will find the fitting (De-)Magnetizer on page no. 271



You will find the fitting module VDE-screwdrivers on page no. 38, 48



970-160

VDE WIRE STRIPPER WITH HANDLE INSULATION

- self-opening by spring
- V-shaped jaws for stripping of plastic insulation from single and multi-wire conductors
- adjustment of opening position to required diameter by adjustable screw with locknut
- for wires from Ø 0,8-6,0 mm
- chrome-plated, polished, with nonslip QUATROLIT®-2C-handles
- handles VDE insulated up to 1.000V, according to EN 60900/IEC 60900
- ELORA-high grade tool steel C45 / 1.0503

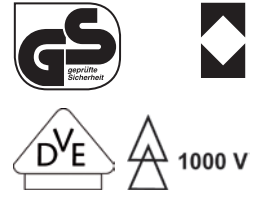

Code	Number	l/mm	Pieces	Weight/g
0970021602100	970-160	160	1	160

980-165

VDE WIRE STRIPPER WITH HANDLE INSULATION

- self-adjusting blades in respect of diameter to be stripped
- for wires from 0,5-5,0 mm
- for stripping of single or multi-wire conductors
- chrome-plated, polished, with QUATROLIT®-2C-handles
- handles VDE insulated up to 1.000V, according to EN 60900/IEC 60900
- ELORA-high grade tool steel C45 / 1.0503

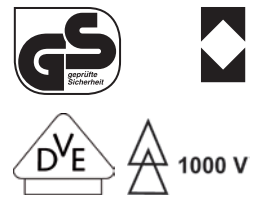

Code	Number	l/mm	Pieces	Weight/g
0980021652100	980-165	165	1	216

950-...

VDE UNIVERSAL SIDE CUTTER WITH HANDLE INSULATION

- high cutting performance with minimal effort
- maximum stability under load by additional inductive hardening
- cutting edge hardness: 63-65 HRC
- for hardened steel wire, piano wire (tensile strength 2300 N/mm²)
- chrome-plated, polished, with nonslip QUATROLIT®-2C-handles
- handles VDE insulated up to 1.000V, according to EN 60900/IEC 60900
- ELORA-high grade tool steel C45 / 1.0503



Code	Number	Ø mm	Ø mm	l/mm	Pieces	Weight/g
0950021452100	950-145	2,5	1,8	145	1	174
0950021602100	950-160	2,8	2,0	160	1	228
0950021802100	950-180	3,0	2,5	180	1	297

955-...

VDE HEAVY DUTY SIDE CUTTER WITH HANDLE INSULATION

- high cutting performance with minimal effort
- maximum stability under load by additional inductive hardening
- cutting edge hardness: 63-65 HRC
- for hardened steel wire, piano wire (tensile strength 2300 N/mm²)
- chrome-plated, polished, with nonslip QUATROLIT®-2C-handles
- handles VDE insulated up to 1.000V, according to EN 60900/IEC 60900
- ELORA-high grade tool steel C45 / 1.0503



Code	Number	Ø mm	Ø mm	l/mm	Pieces	Weight/g
0955021652100	955-165	2,5	2,0	160	1	233
0955022002100	955-200	3,0	2,5	200	1	310

960-...

VDE COMBINATION PLIER WITH HANDLE INSULATION

- German pattern
- strong edition for tough conditions
- lay on cutter box for better cutting
- maximum stability of the blades under load by inductive hardening
- cutting edge hardness: 63-64 HRC
- for medium hard wire, steel wire (tensile strength 1600 N/mm²)
- serrated gripping surface and burner hole
- chrome plated, polished, with nonslip QUATROLIT®-2C-handles
- Plier acc. to DIN ISO 5746
- handles VDE insulated up to 1.000V, according to EN 60900/IEC 60900
- ELORA-high grade tool steel C45 / 1.0503



Code	Number	○ Ø mm	◐ Ø mm	l/mm	Pieces ☞	Weight/g ⚖
0960021652100	960-165	2,5	1,8	165	1	235
0960021852100	960-185	2,8	2,0	185	1	274
0960022052100	960-205	3,0	2,5	205	1	354

930-...

VDE SNIPE NOSE PLIER WITH HANDLE INSULATION

- serrated gripping surface, burner hole and side cutter
- maximum stability under load of the blades by inductive hardening
- chrome plated, polished, with nonslip QUATROLIT®-2C-handles
- Plier acc. to DIN ISO 5745
- handles VDE insulated up to 1.000V, according to EN 60900/IEC 60900
- ELORA-high grade tool steel C45 / 1.0503



Code	Number	l/mm	Pieces ☞	Weight/g ⚖
0930021652100	930-165	165	1	168
0930022052100	930-205	205	1	237

935-45...

VDE SNIPE NOSE PLIER WITH HANDLE INSULATION

- 45° bent, serrated gripping surface, burner hole and side cutter
- maximum stability under load of the blades by inductive hardening
- chrome plated, polished, with nonslip QUATROLIT®-2C-handles
- acc. to DIN ISO 5745
- handles VDE insulated up to 1.000V, according to EN 60900/IEC 60900
- ELORA-high grade tool steel C45 / 1.0503



Code	Number	l/mm	Pieces ☞	Weight/g ⚖
0935201652100	935-45 165	165	1	167
0935202052100	935-45 205	205	1	238

935-90 205

VDE SNIPE NOSE PLIER WITH HANDLE INSULATION

- 90° bent, serrated gripping surface, burner hole and side cutter
- maximum stability under load of the blades by inductive hardening
- chrome plated, polished, with nonslip QUATROLIT®-2C-handles
- Plier similar to DIN ISO 5745
- handles VDE insulated up to 1.000V, according to EN 60900/IEC 60900
- ELORA-high grade tool steel C45 / 1.0503



Code	Number	l/mm	Pieces ☞	Weight/g ⚖
0935292052100	935-90 205	205	1	240

920-165

VDE FLAT NOSE PLIER WITH HANDLE INSULATION

- for holding and bending
- short jaws, serrated gripping surface
- chrome plated, polished, with nonslip QUATROLIT®-2C-handles
- Plier acc. to DIN ISO 5745
- handles VDE insulated up to 1.000V, according to EN 60900/IEC 60900
- ELORA-high grade tool steel C45 / 1.0503



Code	Number	l/mm	Pieces	Weight/g
0920021652100	920-165	165	1	146

940-165

VDE ROUND NOSE PLIER WITH HANDLE INSULATION

- with short jaws, serrated gripping surface
- chrome plated, polished, with nonslip QUATROLIT®-2C-handles
- Plier acc. to DIN ISO 5745
- handles VDE insulated up to 1.000V, according to EN 60900/IEC 60900
- ELORA-high grade tool steel C45 / 1.0503



Code	Number	l/mm	Pieces	Weight/g
0940021652100	940-165	165	1	142

135-5 VDE

WATERPUMP PLIER WITH DIP INSULATION

- continuously variable to any diameter
- self-locking due to gripping surfaces staggered in reverse order and burner hole
- box joint, trap protection
- dull chrome-plated
- handles tested according to EN/IEC 60900, individually tested with 10.000V and approved for 1.000V
- similar to DIN ISO 8976
- ELORA-Chrome-Vanadium 31CrV3 / 1.2208



Code	Number	l/mm	Pieces	Weight/g
0135000052100	135-5 VDE	260	1	622

904-S3

VDE PLIER SET

- 3 pcs.
- carton box packed
- handles VDE insulated up to 1.000V, according to EN 60900/IEC 60900



Code	Number	Contents	Pieces	Weight/g
0904500301000	904-S3	VDE Snipe Nose Plier with handle insulation 930-205 VDE Combination Plier with handle insulation 960-185 VDE Iniversal Side Cutter with handle insulation 950-160	1	720



904-S10

VDE SET

- 10 pcs.
- in red plastic box with 2-colour plastic inlay
- VDE insulated up to 1.000V, according to EN 60900/IEC 60900



Code	Number	Contents	Pieces	Weight/g
0904501001000	904-S10	VDE Voltage Tester 566-150 VDE Snipe Nose Plier with handle insulation 930-205 VDE Universal Side Cutter with handle insulation 950-160 VDE Combination Plier with handle insulation 960-185 VDE Wire stripper with handle insulation 970-160 VDE Screwdriver, plain slotted 900IS-75, 900IS-106, 900IS-12508 VDE Screwdriver, cross slotted 910PH-1 and 2	1	2400

You will find the fitting module VDE-pliers on page no. 40, 49

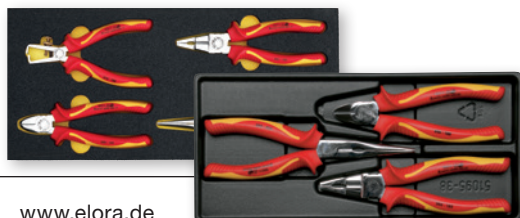

You will find more cable snips on page no. 305



985

VDE CABLE SNIP WITH DIP INSULATION

- maximum stability under load of the blades by inductive hardening
- cutting edge hardness: 65 HRC
- for copper and aluminium wire
- gunmetal-finish
- 2-colour-multilayer safety handles isolation (yellow, red) for easy identification of insulation damages
- VDE insulated up to 1.000V, according to EN 60900/IEC 60900
- ELORA-high grade tool steel C60 / 1.0601

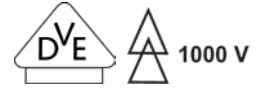

Code	Number	for Wire up to Ø mm	l/mm	Pieces	Weight/g
0985002052100	985	20	205	1	413

977

VDE CABLE KNIFE

- with straight blade, hardened
- with blade protector cap and pin hole
- blade made of stainless steel, with red, impact resistant insulated handle
- VDE insulated up to 1.000V, according to EN 60900/IEC 60900

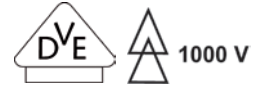

Code	Number	l/mm	Pieces	Weight/g
0977000000000	977	185	6	66

977H

VDE CABLE KNIFE

- with hook blade, hardened
- with blade protector cap and pin hole
- blade made of stainless steel, with red, impact resistant insulated handle
- VDE insulated up to 1.000V, according to EN 60900/IEC 60900



Code	Number	l/mm	Pieces	Weight/g
0977000100000	977H	185	6	64

977A

VDE CABLE KNIFE

- blade with blunt end to protect inner conductors, hardened
- with blade protector cap and pin hole
- blade made of stainless steel, with red, impact resistant insulated handle
- VDE insulated up to 1.000V, according to EN 60900/IEC 60900



Code	Number	l/mm	Pieces	Weight/g
0977000200000	977A	180	6	73

989-...

METAL SAW

- for pinned saw blades 150 mm
- tested according to EN/IEC 60900, individually tested with 10.000V and approved for 1.000 V
- 989-E = Spare blade



Code	Number	l/mm	Pieces	Weight/g
0989000001000	989	265	6	180
0989000001001	989-E	150	6	30

988-...

VDE SINGLE END RING SPANNER, DEEP CRANKED

- 2-colour-multilayer isolation (yellow, red) for easy identification of insulation damages
- VDE insulation up to 1.000V, according to EN 60900/IEC 60900
- tested according to EN/IEC 60900, individually tested with 10.000V and approved for 1.000V
- ELORA Chrome-Vanadium 31CrV3 / 1.2208

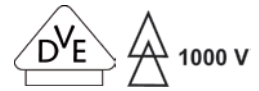

Code	Number	Ø mm	1000 V	VDE	GS	l/mm	Pieces	Weight/g
0988000102100	988-10	10	x	x	x	165	6	80
0988000112100	988-11	11	x	x	x	175	6	100
0988000122100	988-12	12	x	x	x	185	6	110
0988000132100	988-13	13	x	x	x	195	6	120
0988000142100	988-14	14	x	x	x	200	6	150
0988000152100	988-15	15	x	x	x	205	6	155
0988000172100	988-17	17	x	x	x	210	6	180
0988000192100	988-19	19	x	x	x	230	6	245
0988000222100	988-22	22	x	x	x	250	6	353
0988000242100	988-24	24	x	x	x	260	6	357
0988000272100	988-27	27	x	-	-	280	6	438
0988000302100	988-30	30	x	-	-	280	6	454
0988000322100	988-32	32	x	-	-	300	6	580

986-...

RING RATCHET SPANNER

- 2-colour-multilayer isolation (yellow, red) for easy identification of insulation damages
- smallest possible swivel angle 5°
- tested according to EN/IEC 60900, individually tested with 10.000V and approved for 1.000V
- ELORA Chrome-Vanadium 31CrV3 / 1.2208



Code	Number	Ø mm	1000 V	l/mm	Pieces	Weight/g
0986000102100	986-10	10	x	135	6	56
0986000112100	986-11	11	x	135	6	70
0986000122100	986-12	12	x	140	6	90
0986000132100	986-13	13	x	140	6	105
0986000142100	986-14	14	x	150	6	135
0986000152100	986-15	15	x	150	6	155
0986000162100	986-16	16	x	160	6	170
0986000172100	986-17	17	x	160	6	196
0986000182100	986-18	18	x	180	6	200
0986000192100	986-19	19	x	180	6	206

987-...

VDE SINGLE OPEN-ENDED SPANNER

- jaw set at 15°
- 2-colour-multilayer insulation (yellow, red) for easy identification of insulation damages
- VDE insulation up to 1.000V, according to EN 60900/IEC 6090
- tested according to EN/IEC 60900, individually tested with 10.000V and approved for 1.000V
- ELORA-Chrome-Vanadium 31CrV3 / 1.2208



Code	Number	mm	1000 V	VDE	GS	l/mm	Pieces	Weight/g
0987000102100	987-10	10	x	x	x	105	6	42
0987000112100	987-11	11	x	x	x	115	6	48
0987000122100	987-12	12	x	x	x	125	6	58
0987000132100	987-13	13	x	x	x	135	6	68
0987000142100	987-14	14	x	x	x	145	6	84
0987000152100	987-15	15	x	x	x	155	6	88
0987000172100	987-17	17	x	x	x	160	6	120
0987000192100	987-19	19	x	x	x	175	6	160
0987000222100	987-22	22	x	x	x	200	6	237
0987000242100	987-24	24	x	x	x	225	6	300
0987000272100	987-27	27	x	-	-	250	6	380
0987000302100	987-30	30	x	-	-	275	6	485
0987000322100	987-32	32	x	-	-	290	6	590

961-...

ADJUSTABLE WRENCH

- jaw set at 15°
- 2-colour-multilayer insulation (yellow, red) for easy identification of insulation damages
- chrome plated
- handle insulated, tested according to EN/IEC 60900, individually tested with 10.000V and approved for 1.000V
- ELORA-Chrome-Vanadium 31CrV3 / 1.2208



Code	Number	Span Width mm	1000 V	VDE	GS	l/mm	Pieces	Weight/g
0961000082100	961-8	26	x	-	-	200	6	300
0961000102100	961-10	30	x	-	-	250	6	500
0961000122100	961-12	35	x	-	-	300	6	800

905-...

VDE SCREWDRIVER

- for external hexagon screws
- gunmetal-finish blade
- impact resistant QUATROLIT-2C-handle with pin hole
- ELORA-Chrome-Vanadium 31CrV3 / 1.2208
- VDE insulation up to 1.000V, according to EN 60900/IEC 60900, fully insulated blade
- according to DIN3125, ISO2725-1



Code	Number	mm	mm	mm	Pieces	Weight/g
0905000052100	905-5,5	5,5	125	220	6	72
0905000062100	905-6,0	6,0	125	220	6	75
0905000072100	905-7,0	7,0	125	230	6	106
0905000082100	905-8,0	8,0	125	230	6	108
0905000092100	905-9,0	9,0	125	230	6	110
0905000102100	905-10,0	10,0	125	230	6	115
0905000112100	905-11,0	11,0	125	240	6	165
0905000122100	905-12,0	12,0	125	240	6	165
0905000132100	905-13,0	13,0	125	240	6	170

966

REVERSIBLE RATCHET 3/8"

- gear-wheel with safety locking mechanism and quick release button
- 2-colour-multilayer insulation (yellow, red) for easy identification of insulation damages
- insulated, tested according to EN/IEC 60900, individually tested with 10.000V and approved for 1.000V
- ELORA-Chrome-Vanadium 31CrV3 / 1.2208
- square drive according to DIN 3120-A 10 ISO1174, with ball locking device



10



3/8"

Code	Number	l/mm	Pieces	Weight/g
0966000002100	966	200	1	356

969-...

SOCKET 3/8"

- square drive according to DIN 3120-C 10 ISO1174, with ball retaining groove
- chrome-plated
- 2-colour-multilayer insulation (yellow, red) for easy identification of insulation damages
- tested according to EN/IEC 60900, individually tested with 10.000V and approved for 1.000V
- ELORA Chrome-Vanadium 31CrV3 / 1.2208



10



3/8"

Code	Number	Ø/mm	l/mm	Pieces	Weight/g
0969000092100	969-9	9	28	6	31
0969000102100	969-10	10	28	6	31
0969000112100	969-11	11	28	6	33
0969000122100	969-12	12	28	6	33
0969000132100	969-13	13	28	6	34
0969000142100	969-14	14	30	6	36
0969000152100	969-15	15	30	6	44
0969000162100	969-16	16	30	6	50
0969000172100	969-17	17	30	6	54
0969000182100	969-18	18	30	6	58
0969000192100	969-19	19	30	6	70
0969000202100	969-20	20	30	6	72
0969000212100	969-21	21	30	6	77
0969000222100	969-22	22	32	6	94

967-...

EXTENSION BAR 3/8"

- with safety lock screw
- chrome-plated
- 2-colour-multilayer insulation (yellow, red) for easy identification of insulation damages
- ELORA-Chrome-Vanadium 31CrV3 / 1.2208
- tested according to EN/IEC 60900, individually tested with 10.000V and approved for 1.000V



10



3/8"

Code	Number	l/mm	Pieces	Weight/g
0967001252100	967-125	125	6	154
0967002502100	967-250	250	6	280

968

T-HANDLE 3/8"

- with safety screw lock
- chrome-plated
- 2-colour-multilayer insulation (yellow, red) for easy identification of insulation damages
- ELORA-Chrome-Vanadium 31CrV3 / 1.2208
- tested according to EN/IEC 60900, individually tested with 10.000V and approved for 1.000V



10



3/8"

Code	Number	l/mm	Pieces	Weight/g
0968002002100	968	200	6	450

990

TORQUE WRENCH 1/2"

- with noticeable and audible „click“ mechanism
- manually adjustable, double scale unit with Nm and ft.lb.
- 2-colour-multilayer insulation (yellow, red) for easy identification of insulation damages
- accuracy + -4% of set value
- square drive according to DIN 3120-A 12,5, ISO1174, with locking device
- tested according to EN/IEC 60900, individually tested with 10.000V and approved for 1.000V

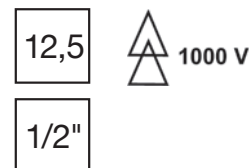

Code	Number	Measuring range ft.lb.	Measuring range Nm	l/mm	Pieces	Weight/g
0990000001000	990	5-35	5-50	370	1	1140

972

VDE REVERSIBLE RATCHET 1/2"

- gear-wheel with safety locking mechanism and quick release button
- 2-colour-multilayer insulation (yellow, red) for easy identification of insulation damages
- VDE insulated up to 1.000V, according to EN60900/IEC 60900
- ELORA-Chrome-Vanadium 31CrV3/1.2208
- square drive according to DIN 3120-A 12,5, ISO1174, with ball locking device

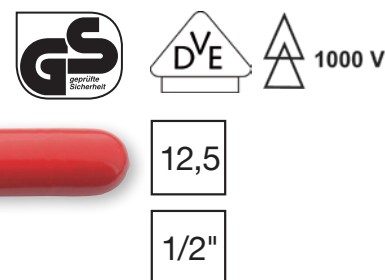

Code	Number	l/mm	Pieces	Weight/g
0972000002100	972	260	1	690

971-...

VDE SOCKET 1/2"

- female square according to DIN 3120-C 12,5, ISO1174, with ball retaining groove
- chrome-plated
- 2-colour-multilayer insulation (yellow, red) for easy identification of insulation damages
- VDE insulated up to 1.000V, according to EN60900/IEC 60900:2004
- tested according to EN/IEC 60900, individually tested with 10.000V and approved for 1.000V
- ELORA-Chrome-Vanadium 31CrV3 / 1.2208

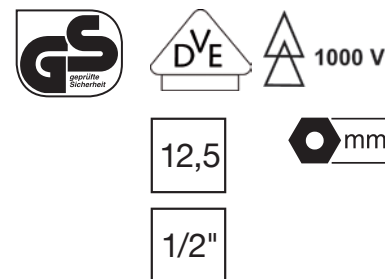

Code	Number	mm	Length without insulation mm	VDE	GS	Pieces	Weight/g
0971000092100	971-9	9	40	-	x	6	58
0971000102100	971-10	10	40	x	x	6	60
0971000112100	971-11	11	40	x	x	6	63
0971000122100	971-12	12	40	x	x	6	64
0971000132100	971-13	13	40	x	x	6	64
0971000142100	971-14	14	40	x	x	6	63
0971000152100	971-15	15	40	x	x	6	67
0971000172100	971-17	17	40	x	x	6	74
0971000182100	971-18	18	40	x	x	6	91
0971000192100	971-19	19	40	x	x	6	83
0971000212100	971-21	21	40	x	x	6	107
0971000222100	971-22	22	40	x	x	6	114
0971000242100	971-24	24	40	-	x	6	117
0971000272100	971-27	27	43	-	x	6	181
0971000302100	971-30	30	45	-	x	6	195
0971000322100	971-32	32	45	-	x	6	200

971-IN...

VDE SCREWDRIVER SOCKET 1/2"

- only to use with ELORA-No. 972, 973 and 974-125
- chrome-plated
- female square according to DIN 3120-C 12,5, ISO1174, with ball retaining groove
- VDE insulated up to 1.000V, according to EN60900/IEC 60900
- ELORA-Chrome-Vanadium 31CrV3 / 1.2208



12,5



1/2"



Code	Number	mm	Length without insulation mm	Pieces	Weight/g
0971000045100	971-IN4	M5	70	6	86
0971000055100	971-IN5	M6	70	6	87
0971000065100	971-IN6	M8	70	6	107
0971000085100	971-IN8	M10	70	6	108
0971000105100	971-IN10	M12	70	6	109

973

VDE-T-BAR 1/2"

- with safety screw lock
- chrome plated
- 2-colour-multilayer insulation (yellow, red) for easy identification of insulation damages
- VDE insulated up to 1.000V, according to EN60900/IEC 60900
- ELORA-Chrome-Vanadium 31CrV3 / 1.2208



12,5

1/2"

Code	Number	l/mm	Width mm	Pieces	Weight/g
0973002052100	973	210	145	1	440

974-...

EXTENSION BAR

- with safety screw lock
- chrome-plated
- 2-colour-multilayer insulation (yellow, red) for easy identification of insulation damages
- tested according to EN/IEC 60900, individually tested with 10.000V and approved for 1.000V
- ELORA-Chrome-Vanadium 31CrV3 / 1.2208



12,5

1/2"

Code	Number	l/mm	Pieces	Weight/g
0974001252100	974-125	125	3	220
0974002502100	974-250	250	3	420

971-S13

VDE SOCKET SET 1/2"

- 13 pcs.
- in red plastic box with 2-colour-plastic inlay
- 2-colour-multilayer insulation (yellow, red) for easy identification of insulation damages
- ELORA-Chrome-Vanadium 31CrV3 / 1.2208



12,5

1/2"



Code	Number	Contents	Pieces	Weight/g
0971500131000	971-S13	VDE Sockets 971-10, 12, 13, 14, 17, 19, 22, 24 mm VDE Reversible Ratchet 972 Extension Bar 974-125, 250 T-Handle 973 VDE-Screwdriver 900-IS 12508	1	3600



Pliers, cutters and shears

Precision Pliers _____	Page 326
Profi Classic Pliers _____	Page 332
Different Pliers _____	Page 335
Waterpump Pliers and Pipe Wrenches _____	Page 337
Heavy duty Jaw Cutters _____	Page 342
Revolving punch Pliers and Eyes _____	Page 344
Tinmas Shears _____	Page 345
Shears _____	Page 349
Grip Pliers _____	Page 350
Circlip Pliers _____	Page 360



The precision finishing for which ELORA is known takes place daily on 8 grinding chocks. This ensures a perfect shine and a high-quality surface finish.

490-BI...

HEAVY DUTY SIDE CUTTER

- high cutting performance with minimal effort
- maximum stability under load by additional inductive hardening
- cutting edge hardness: 63-65 HRC
- for hardened steel wire, piano wire (tensile strength 2300 N/mm²)
- nonslip QUATROLIT®-2C-handles
- chrome-plated, polished
- ELORA-high grade tool steel C60 / 1.0601
- according to DIN ISO 5749



Code	Number	Ø mm	Ø mm	l/mm	l/Inch	Pieces	Weight/g
0490001452000	490BI-145	2,0	1,6	145	5,75	1	161
0490001652000	490BI-165	2,5	2,0	165	6,5	1	238
0490002002000	490BI-200	3,0	2,5	200	8	1	310

492-BI...

SIDE CUTTER

- oval head
- maximum stability under load by inductive hardening
- cutting edge hardness: 63-65 HRC
- for medium hard wire, steel wire (tensile strength 1600N/mm²)
- nonslip QUATROLIT®-2C-handles
- chrome-plated, polished
- ELORA-high grade tool steel C60 / 1.0601
- according to DIN ISO 5749



Code	Number	Ø mm	Ø mm	l/mm	l/Inch	Pieces	Weight/g
0492001302000	492BI-130	2,3	1,5	130	5,25	1	145
0492001452000	492BI-145	2,5	1,8	145	5,75	1	187

468-BI

WIRE STRIPPER/CUTTER

- side cutter with dual function (cutting and stripping of insulation)
- stripping holes for single and multi-wire conductors with 1,5 mm² and 2,5 mm² diameter
- oval head
- maximum stability under load by inductive hardening
- cutting edge hardness: 63-65 HRC
- for medium hard wire, steel wire (tensile strength 1600N/mm²)
- nonslip QUATROLIT®-2C-handles
- chrome-plated, polished
- ELORA-high grade tool steel C60 / 1.0601
- similar DIN ISO 5749



Code	Number	Ø mm	Ø mm	l/mm	l/Inch	Pieces	Weight/g
0468000002000	468-BI	2,8	2,0	160	6,25	1	185

494 BI

WIRE STRIPPER WITH RESTRICTED OPENING

- self opening by spring
- V-shaped jaws for stripping of plastic insulation from single and multi-wire conductors
- adjustment of opening position to required diameter by adjustable screw with locknut
- for wires from Ø 0,8 to 6,0 mm
- nonslip QUATROLIT®-2C-handles
- chrome-plated, polished
- ELORA-high grade tool steel C45 / 1.0503



Code	Number	l/mm	l/Inch	Pieces	Weight/g
049400002000	494BI	160	6,25	1	199

494S-0,5 BI

WIRE STRIPPER

- self-adjusting blades in respect of diameter to be stripped
- for stripping of single or multi-wire conductors
- for wires from Ø 0,5 to 5,0 mm
- nonslip QUATROLIT®-2C-handles
- chrome-plated, polished
- ELORA-high grade tool steel C45 / 1.0503



Code	Number	l/mm	l/Inch	Pieces	Weight/g
0494000052000	494S-0,5BI	160	6,5	1	215

485-BI

HEAVY DUTY END CUTTER

- maximum stability under load by inductive hardening
- cutting edge hardness: 63-65 HRC
- for hardened steel wire, piano wire (tensile strength 2300N/mm²)
- nonslip QUATROLIT®-2C-handles
- chrome-plated, polished
- ELORA-high grade tool steel C60 / 1.0601
- similar DIN ISO 5748



Code	Number	Ø mm	Ø mm	l/mm	l/Inch	Pieces	Weight/g
048500002000	485BI	2,5	2,2	160	6,5	1	230

495-BI...

COMBINATION PLIER, GERMAN PATTERN

- strong edition for tough conditions
- lay on cutter box for better cutting
- maximum stability under load by inductive hardening
- cutting edge hardness: 63-64 HRC
- for medium hard wire, steel wire (tensile strength 1600N/mm²)
- serrated gripping surface and burner hole
- nonslip QUATROLIT®-2C-handles
- chrome-plated, polished
- ELORA-high grade tool steel C45 / 1.0503
- according to DIN ISO 5746



Code	Number	Ø mm	Ø mm	l/mm	l/Inch	Pieces	Weight/g
0495001652000	495BI-165	2,5	1,8	165	6,5	1	224
0495001852000	495BI-185	2,8	2,0	185	7,25	1	272
0495002052000	495BI-205	3,0	2,5	205	8	1	353

470-BI...

SNIBE NOSE PLIER WITH SIDE CUTTER, STRAIGHT PATTERN

- serrated gripping surface, burner hole and side cutter
- maximum stability under load of the blades by inductive hardening
- nonslip QUATROLIT®-2C-handles
- chrome-plated, polished
- ELORA-high grade tool steel C45 / 1.0503
- according to DIN ISO 5745



Code	Number	l/mm	l/Inch	Pieces	Weight/g
0470001452000	470BI-145	145	5,75	1	130
0470001652000	470BI-165	165	6,5	1	164
0470000002000	470BI-200	200	8	1	238

471-45 BI...

SNIBE NOSE PLIER WITH SIDE CUTTER, BENT

- 45° bent, serrated gripping surface, burner hole and side cutter
- maximum stability under load of the blades by inductive hardening
- nonslip QUATROLIT®-2C-handles
- chrome-plated, polished
- ELORA-high grade tool steel C45 / 1.0503
- according to DIN ISO 5745



Code	Number	l/mm	l/Inch	Pieces	Weight/g
0471000002000	471-45 BI 200	200	8	1	239
0471001602000	471-45 BI 165	165	6,5	1	165

471-90 BI...

SNIBE NOSE PLIER WITH SIDE CUTTER, BENT

- 90° bent, serrated gripping surface, burner hole and side cutter
- maximum stability under load of the blades by inductive hardening
- nonslip QUATROLIT®-2C-handles
- chrome-plated, polished
- ELORA-high grade tool steel C45 / 1.0503
- similar DIN ISO 5745



Code	Number	l/mm	l/Inch	Pieces	Weight/g
0471091602000	471-90 BI 165	165	6,5	1	166
0471092002000	471-90 BI 200	200	8	1	239

476-BI...

FLAT NOSE PLIER

- for holding and bending
- short jaws, serrated gripping surface
- nonslip QUATROLIT®-2C-handles
- chrome-plated, polished
- ELORA-high grade tool steel C45 / 1.0503
- according to DIN ISO 5745



Code	Number	l/mm	l/Inch	Pieces	Weight/g
0476001452000	476BI-145	145	5,75	1	130
0476001702000	476BI-170	165	6,5	1	143

477-BI-...

ROUND NOSE PLIER

- with long jaws, serrated gripping surface
- nonslip QUATROLIT®-2C-handles
- chrome-plated, polished
- ELORA-high grade tool steel C45 / 1.0503
- according to DIN ISO 5745



Code	Number	l/mm	l/Inch	Pieces	Weight/g
0477001452000	477BI-145*	145	5,75	1	125
0477001702000	477BI-170	160	6,25	1	175

404-S3

MECHANIC'S PLIER SET

- 3 pcs.
- carton box packed
- nonslip QUATROLIT®-2C-handles
- chrome-plated, polished



Code	Number	Contents	Pieces	Weight/g
0404500301000	404-S3	470-BI 200 Snap Nose Plier with side cutter, straight pattern 490-BI 165 Heavy Duty Side Cutter 495-BI 185 Engineer's Plier, German pattern	1	818

404-S31

MECHANIC'S PLIER SET

- 3 pcs.
- carton box packed
- chrome-plated, polished



Code	Number	Contents	Pieces	Weight/g
0404500311000	404-S31	132-240 Waterpump Plier 490-BI 165 Heavy Duty Side Cutter 495-BI 185 Engineer's Plier, German pattern	1	975

You will find VDE- and electronic pliers on page no. 312



404-S4

ELECTRICIAN'S PLIER SET

- 4 pcs.
- carton box packed
- nonslip QUATROLIT®-2C-handles
- chrome-plated, polished



Code	Number	Contents	Pieces	Weight/g
0404500401000	404-S4	470-BI 165 Snipe Nose Plier with side cutter, straight pattern 490-BI 165 Heavy Duty Side Cutter 494 BI Wire Stripper with restricted opening 495-BI 185 Engineer's Plier, German pattern	1	980

504-S8

MECHANIC' SET

- 8 pcs.
- assortment in convenient plastic case



Code	Number	Contents	Pieces	Weight/g
0504500801000	504-S8	470-BI 200 Snipe Nose Plier with side cutter, straight pattern 490-BI 165 Heavy Duty Side Cutter 495-BI 185 Engineer's Plier, German pattern 545-IS 100, IS 125, IS 150 Screwdriver, plain slotted 547-PH1, PH2 Screwdriver, cross slotted	1	1600

949 H

PLIERS HOLDER

- for presentation of pliers on perforated display walls
- empty, without pliers



Code	Number	l/mm	Pieces	Weight/g
0949000206000	949 H	200	1	160

You will find special automotive pliers on page no. 431, 437



08

You will find the matching OMS-10 module on page no. 38

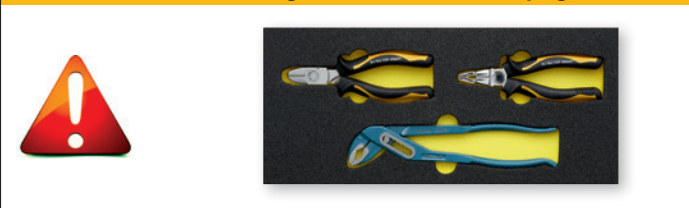

You will find the matching OMS-5 module on page no. 39

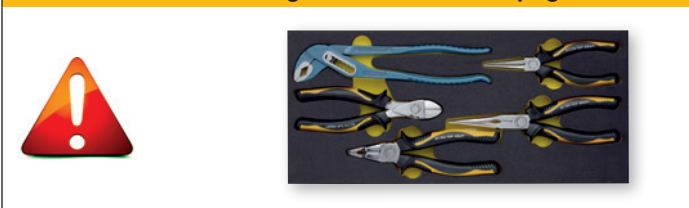

You will find the matching OMS-21 module on page no. 49

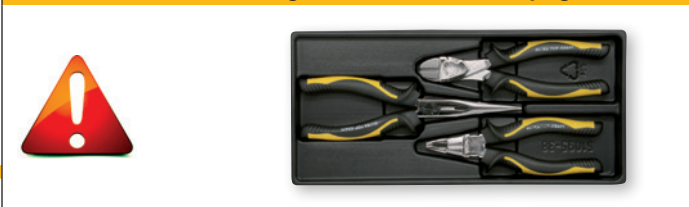

392-...

SIDE CUTTER

- oval head
- maximum stability under load by inductive hardening
- cutting edge hardness: 63-65 HRC
- for medium hard wire, steel wire (tensile strength 1600N/mm²)
- ground, with red dip insulated handles
- ELORA-high grade tool steel C60 / 1.0601
- according to DIN ISO 5749

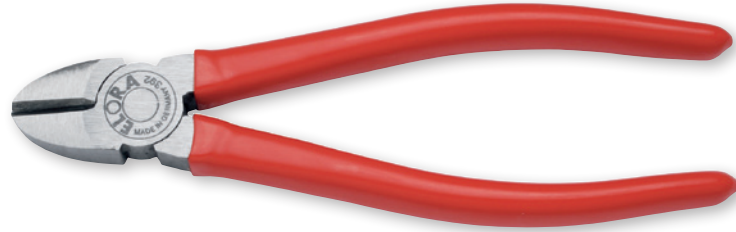

Code	Number	Ø mm	Ø mm	l/mm	l/Inch	Pieces	Weight/g
0392001455100	392-145	2,2	1,4	145	5,75	1	150
0392001605100	392-160	2,4	1,7	160	6,5	1	180

389-...

HEAVY DUTY SIDE CUTTER

- high cutting performance with minimal effort
- maximum stability under load by inductive hardening
- cutting edge hardness: 63-65 HRC
- for hardened steel wire, piano wire (tensile strength 2300 N/mm²)
- ground, with red dip insulated handles
- ELORA-high grade tool steel C60 / 1.0601
- according to DIN ISO 5749



Code	Number	Ø mm	Ø mm	l/mm	l/Inch	Pieces	Weight/g
0389001705100	389-170	2,5	2,0	165	6,5	1	220
0389002005100	389-200	3,0	2,5	200	8	1	260

395-...

COMBINATION PLIER

- strong edition for tough conditions
- maximum stability under load by inductive hardening
- cutting edge hardness: 63-64 HRC
- for medium hard wire, steel wire (tensile strength 1600N/mm²)
- serrated gripping surface and burner hole
- ground, with red dip insulated handles
- ELORA-high grade tool steel C45 / 1.0503
- according to DIN ISO 5746



Code	Number	Ø mm	Ø mm	l/mm	l/Inch	Pieces	Weight/g
0395001605100	395-160	2,5	1,8	160	6,5	1	190
0395001805100	395-180	2,8	2,0	180	7,5	1	260
0395002005100	395-200	3,0	2,5	200	8	1	330

370-...

SNIBE NOSE PLIER WITH SIDE CUTTER, STRAIGHT

- serrated gripping surface and side cutter
- maximum stability under load of the blades by inductive hardening
- ground, with red dip insulated handles
- ELORA-high grade tool steel C45 / 1.0503
- according to DIN ISO 5745

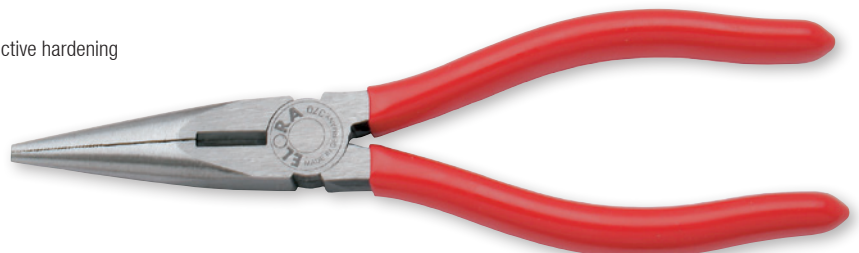

Code	Number	l/mm	l/Inch	Pieces	Weight/g
0370001605100	370-160	165	6,5	1	130
0370002005100	370-200	200	8	1	170

371-...

SNIPE NOSE PLIER WITH SIDE CUTTER, BENT

- 45° bent, serrated gripping surface and side cutter
- maximum stability under load of the blades by inductive hardening
- ground, with red dip insulated handles
- ELORA-high grade tool steel C45 / 1.0503
- according to DIN ISO 5745

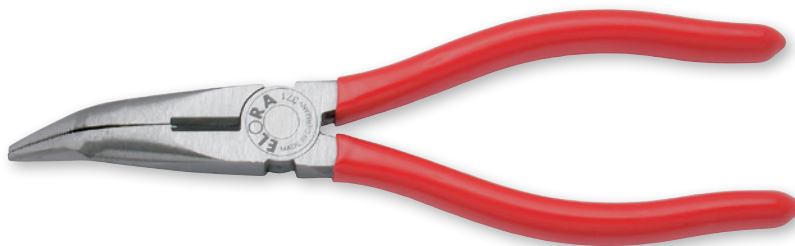

Code	Number	l/mm	l/Inch	Pieces	Weight/g
0371001605100	371-160	165	6,5	1	130
0371002005100	371-200	200	8	1	170

376-160

FLAT NOSE PLIER

- for holding and bending
- long, flat jaws, rippled serrated surface
- ground, with red dip insulated handles
- ELORA-high grade tool steel C45 / 1.0503
- according to DIN ISO 5745

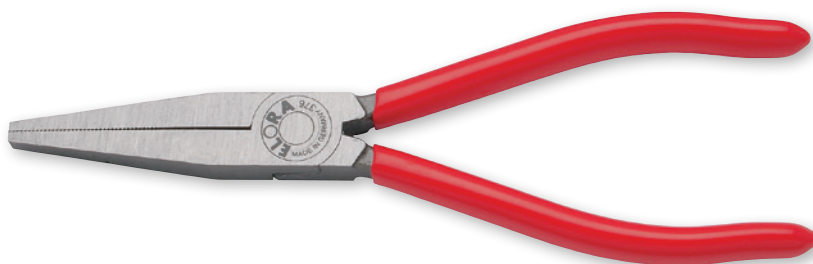

Code	Number	l/mm	l/Inch	Pieces	Weight/g
0376001605100	376-160	160	6,5	1	140

377-160

ROUND NOSE PLIER

- long jaws, serrated gripping surface
- ground, with red dip insulated handles
- ELORA-high grade tool steel C45 / 1.0503
- according to DIN ISO 5745



Code	Number	l/mm	l/Inch	Pieces	Weight/g
0377001605100	377-160	160	6,5	1	118

You will find VDE- and electronic pliers on page no. 312



304-S3

MECHANIC'S PLIER ASSORTMENT

- 3 pcs.
- carton box packed
- ground, with red dip insulated handles



Code	Number	Contents	Pieces	Weight/g
0304500301000	304-S3	370-200 Snipe Nose Plier with side cutter, straight 389-170 Heavy Duty Side Cutter 395-180 Combination Plier	1	715

304-S31

MECHANIC'S PLIER ASSORTMENT

- 3 pcs.
- carton box packed



Code	Number	Contents	Pieces	Weight/g
0304500311000	304-S31	132-240 Waterpump plier 389-170 Heavy Duty Side Cutter 395-180 Combination Plier	1	924

493 BI

MULTI PURPOSE "FIT" SHEAR PLIER

- combination of side, edge, combination plier and tin snip
- nonslip QUATROLIT®-2C-handles
- ELORA-high grade tool steel C45 / 1.0503



Code	Number	l/mm	l/Inch	Pieces	Weight/g
0493000000001	493 BI	200	8	1	300

493-1

MULTI PURPOSE PLIER "MULTI-TOOL"

- Multifunctional tool for the industry, automotive, construction, sanitary and agriculture sector
- hammer, water pump plier, wire cutter, combination plier, side cutter, wrench and driller in one tool
- black, ground head
- dip insulated PVC handles
- ELORA-high grade tool steel C60 / 1.0601



Code	Number	l/mm	l/Inch	Pieces	Weight/g
0493000010000	493-1	250	10	1	578

321-...

CARPENTER'S PINCER

- for highest operational demands
- inductive hardened cutting blades
- cutting blades hardness 61-63 HRC
- gunmetal-finish, ground head
- ELORA-high grade tool steel C45 / 1.0503
- according to DIN ISO 9243 Form A



Code	Number	Ø mm	l/mm	l/Inch	Pieces	Weight/g
0321001605100	321-160	1,8	160	6,5	1	253
0321001805100	321-180	2,0	180	7	1	317
0321002005100	321-200	2,2	200	8	1	414
0321002255100	321-225	2,2	230	9	1	455

499-...

CONCRETER'S NIPPER

- Mechanic's nipper for heaviest action
- inductive hardened cutting edge, cutting blade hardness 61-63HRC
- gunmetal-finish, ground head
- ELORA-high grade tool steel C45 / 1.0503
- according to DIN ISO 9242 Form A



Code	Number	Ø mm	l/mm	l/Inch	Pieces	Weight/g
0499002205100	499-220	2,4	220	9	1	356
0499002505100	499-250	2,4	250	10	1	438
0499002805100	499-280	2,8	280	11	1	467

489-...

SEAMING PLIER

- for seaming of metal sheets
- forged, black laquered
- jaw width 60 mm
- Model ELORA-No. 489-1 straight
- Model ELORA-No. 489-2 45° bent
- Model ELORA-No. 489-3 90° bent
- high grade tool steel C60 / 1.0601



489-1



489-2



489-3

Code	Number	l/mm	l/Inch	Pieces	Weight/g
0489000011000	489-1	280	11	1	799
0489000021000	489-2	280	11	1	827
0489000031000	489-3	280	11	1	772

1644-10

SEAMING OR BENDING PLIER

- for seaming of metal sheets
- forged, black laquered
- red dip insulated handles
- high grade tool steel



Code	Number	l/mm	Pieces	Weight/g
1644000107000	1644-10	255	1	450

130BI-240

WATERPUMP PLIER

- lay-on slip joint and teeth cut-out
- tooth inductive hardened, trap protection
- chrome plated, polished, dip insulated handles
- ELORA-Chrome-Vanadium 31 CrV 3 / 1.2208
- according to DIN ISO 8976, Form A



Code	Number	Pipe Ø mm	Pipe Ø Zoll	l/mm	l/Inch	Pieces	Weight/g
0130002402000	130BI-240	46	1.1/4	250	10	1	354

132-...

WATERPUMP PLIER

- box joint
- self-locking due to gripping surfaces staggered in reverse order
- teeth inductive hardened, trap protection
- ELORA-No. 132-190 adjustable in 6 positions, all other adjustable in 7 positions
- blue laquered, polished jaws
- handles with forged raffle
- ELORA-Chrome-Vanadium 31 CrV 3 / 1.2208
- according to DIN ISO 8976, Form C



Code	Number	Pipe Ø mm	Pipe Ø Zoll	l/mm	l/Inch	Pieces	Weight/g
0132001906500	132-190	34	1	175	7	1	196
0132002406500	132-240	43	1.1/4	250	10	1	345
0132003006500	132-300	48	1.1/2	300	12	1	502

132-S3

WATERPUMP PLIER ASSORTMENT

- 3 pcs.
- carton box packed
- box joint
- self-locking due to gripping surfaces staggered in reverse order
- teeth inductive hardened, trap protection
- ELORA-No. 132-190 adjustable in 6 positions, all others adjustable in 7 positions
- blue laquered, polished jaws
- handles with forged raffle
- ELORA-Chrome-Vanadium 31 CrV 3 / 1.2208
- according to DIN ISO 8976, Form C



Code	Number	Contents	Pieces	Weight/g
0132500036500	132-S3	Waterpump plier: 132-190, 132-240, 132-300	1	1135

131

GROOVE WATERPUMP PLIER

- forged lay-on slip joint
- self-locking due to gripping surfaces staggered in reverse order
- teeth inductive hardened, trap protection
- nonslip QUATROLIT®-2C-handles
- chrome-plated, polished
- ELORA-Chrome-Vanadium 31 CrV3 / 1.2208
- according to DIN ISO 8976, Form B



Code	Number	Pipe Ø mm	Pipe Ø Zoll	l/mm	l/Inch	Pieces	Weight/g
0131002402000	131BI-240	50	1.3/4	240	10	1	501

133-250

QUICK GRIPPING WATERPUMP PLIER

- quick adjustment by press a button
- self-locking due to gripping surfaces staggered in reverse order
- box joint
- absolute safe, no displacement during work
- teeth inductive hardened, trap protection
- chrome-plated, polished jaw
- ELORA-Chrome-Vanadium 31 CrV3 / 1.2208
- according to DIN ISO 8976, Form B



Code	Number	l/mm	l/Inch	Pieces	Weight/g
0133002501000	133-250	250	10	1	482

134-...

QUICK GRIPPING WATERPUMP PLIER

- quick release due to box joint teeth raster
- absolute safe, no displacement during work
- self-locking due to gripping surfaces staggered in reverse order
- teeth inductive hardened, trap protection
- chrome-plated, polished jaws
- Chrome-Vanadium 31 CrV3 / 1.2208
- according to DIN ISO 8976, Form C



Code	Number	Pipe Ø mm	Pipe Ø Zoll	l/mm	l/Inch	Pieces	Weight/g
0134002501000	134-250	60	2.1/4	250	10	1	522
0134003751000	134-375	70	2.3/4	375	15	1	1104

135-...

WATERPUMP PLIER

- groove box joint, continuously variable
- self-locking due to gripping surfaces staggered in reverse order
- teeth inductive hardened, trap protection
- MB: chrome-plated, polished jaws
- BI: nonslip QUATROLIT®-2C-handles
- chrome-plated, polished jaws
- ELORA-Chrome-Vanadium 31 CrV3 / 1.2208
- according to DIN ISO 8976, Form C



Code	Number	Pipe Ø mm	Pipe Ø Zoll	l/mm	l/Inch	Pieces	Weight/g
0135000051000	135-5MB	50	2.1/4	260	10.1/2	1	496
0135000052000	135-5BI	60	2.3/4	260	10.1/2	1	576

66A-...

PIPE WRENCH

- Swedish type
- for highest operational demands
- head angled at 90°
- drop forged, hardened and tempered
- teeth additionally inductive hardened
- self-locking due to gripping surfaces staggered in reverse order
- roll non-volatile
- red laquered
- ELORA-Chrome-Vanadium 31 CrV3 / 1.2208
- according to DIN ISO 5234, Form A



Code	Number	Pipe Ø mm	Pipe Ø Zoll	l/mm	l/Inch	Pieces	Weight/g
0066100346000	66A-1	40	1	340	13,5	1	1100
0066100426000	66A-1.1/2	55	1.1/2	400	16	1	1420
0066100496000	66A-2	67	2	530	21	1	2300
0066100636000	66A-3	103	3	720	29	1	3400

67E-...

PIPE WRENCH

- for highest operational demands
- head angled at 45°
- drop forged, hardened and tempered
- teeth additionally inductive hardened
- self-locking due to gripping surfaces staggered in reverse order
- roll non-volatile
- red laquered, polished jaws
- ELORA-Chrome-Vanadium 31 CrV3 / 1.2208
- according to DIN ISO 5234, Form B



Code	Number	Pipe Ø mm	Pipe Ø Zoll	l/mm	l/Inch	Pieces	Weight/g
0067100236000	67E-1/2	25	1/2	270	11	1	480
0067100346000	67E-1	40	1	320	13	1	990
0067100426000	67E-1.1/2	55	1.1/2	420	17	1	1380
0067100496000	67E-2	67	2	570	23	1	2860
0067100636000	67E-3	103	3	700	28	1	4260

68SN-...

PIPE WRENCH

- Swedish type
- 3 point S-jaw pipe wrench for highest operational demands
- head angled at 45°
- drop forged, hardened and tempered
- teeth additionally inductive hardened
- self-locking due to gripping surfaces staggered in reverse order
- roll non-volatile
- red laquered, polished jaws
- ELORA-Chrome-Vanadium 31 CrV3 / 1.2208
- according to DIN ISO 5234, Form C



Code	Number	Pipe Ø mm	Pipe Ø Zoll	l/mm	l/Inch	Pieces	Weight/g
0068100236000	68SN- 1/2	25	1/2	270	11	1	420
0068100346000	68SN- 1	40	1	320	13	1	820
0068100426000	68SN- 1.1/2	55	1.1/2	420	17	1	1340
0068100496000	68SN- 2	67	2	570	23	1	2640
0068100636000	68SN- 3	103	3	700	28	1	4200

136-...

QUICK ACTION PIPE WRENCH

- easy and quick adjusting due to knurled adjustment
- teeth additionally inductive hardened
- self-locking due to gripping surfaces staggered in reverse order
- high grade tool steel



Code	Number	Pipe Ø mm	Pipe Ø Zoll	l/mm	l/Inch	Pieces	Weight/g
0136001755100	136-175	35	1.3/8	175	7	1	300
0136002255100	136-225	42	1.5/8	225	9	1	510
0136002755100	136-275	61	2.3/8	275	11	1	815
0136003155100	136-315	74	3	315	12	1	985
0136003605100	136-360	90	3.9/16	360	14	1	1620

75-...

PIPE WRENCH "STILLSON"

- American type
- adjustable with knurled adjustment
- forged pieces hardened and tempered
- teeth additionally inductive hardened and staggered in reverse order
- steel-grey, handles blue laquered, polished jaws
- special high grade tool steel
- US-Norm GGG-W-651, class A, Type 1

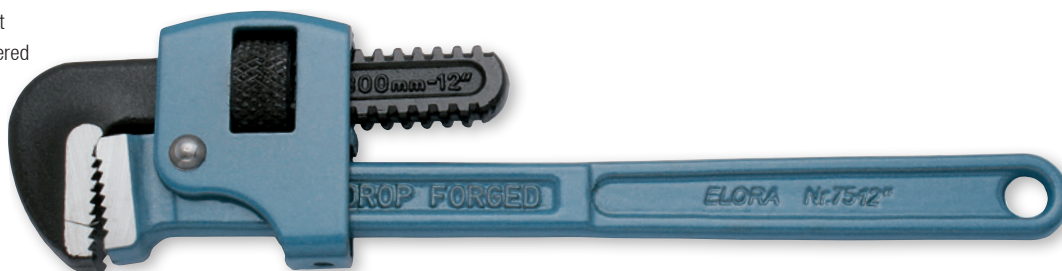

Code	Number	Pipe Ø mm	Pipe Ø Zoll	l/mm	l/Inch	Pieces	Weight/g
0075000105200	75-10	35	1.3/8	250	10	1	550
0075000125200	75-12	43	1.3/4	300	12	1	800
0075000145200	75-14	49	1.7/16	350	14	1	965
0075000185200	75-18	61	2.3/8	450	18	1	1650
0075000245200	75-24	77	3	600	24	1	3150

137

PLUMBING WRENCH

- for chrome and nickel plated bathroom fittings
- with lever clamp
- with exchangeable plastic jaws, 8mm wide
- gunmetal-finish
- ELORA-Chrome-Vanadium 31 CrV3 / 1.2208



Code	Number	Span Width mm	l/mm	Pieces	Weight/g
0137000000000	137	65	275	1	757

138

SIPHON OR CONNECTOR PLIER

- loosening and tightening of pipe connections with round union nuts from \varnothing 25 mm
- loosening and tightening of ring lock connectors (like Canon connectors)
- drop forged, with slip on joint, 4 adjusting positions
- serrated jaws, jaw width 10 mm
- chrome-plated, PVC-dip insulated handles
- ELORA-No. 138-A with bolted plastic jaws
- ELORA-Chrome-Vanadium 31 CrV3 / 1.2208



Code	Number	Span Width mm	l/mm	Pieces	Weight/g
0138000000000	138	80	240	1	348
0138000001000	138-A	60	240	1	280
0138000000001	138-E	1 pair spare jaws for 138-A		1	5

462

BLIND-RIVET NUT PLIER

- to process blind rivets
- mandrel intake exchangeable on the head
- for blind rivets diameters: 2.4, 3.2, 4.0 and 4.8 mm
- black, plier body made of aluminium, leverage made of metal sheet
- PVC handles



Code	Number	l/mm	Pieces	Weight/g
0462000000000	462	280	1	699

491-2

WIRE CENTRE CUTTER

- for cutting of soft and hard wire
- maximum stability under load by additionally inductive hardening
- cutting edge hardness: 63-65 HRC
- for hardened steel wire, piano wire (tensile strength 2300 N/mm²)
- ground with red dip insulated handles
- ELORA-high grade tool steel C60 / 1.0601



Code	Number	Ø mm	l/mm	l/Inch	Pieces	Weight/g
0491000011000	491-2	2	200	8	1	354

288-...

BOLT CUTTER

- inductive hardened jaws on the cutter head
- cutting capacity up to 48 HRC hardness
- easy and precise readjusting with double eccentric screws
- limbs made of steel tube with plastic handles
- jaws made of special high grade tool steel
- according to DIN ISO 9242

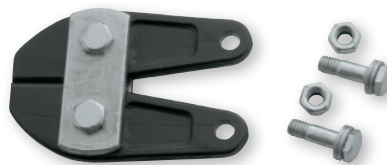

Code	Number	19 HRC Ø mm	40 HRC Ø mm	44 HRC Ø mm	l/mm	l/Inch	Pieces	Weight/g
0288003406000	288-340	6	5	-	330	13	1	775
0288004006000	288-400	6	5	-	400	16	1	850
0288004506000	288-450	8	7	5	460	18	1	1670
0288006106000	288-610	9	8	7	620	24	1	2370
0288008006000	288-800	11	9	8	780	30	1	4570
0288009006000	288-900	13	11	9	900	36	1	5100
0288003416000	288E-340			Spare jaw			1	234
0288004016000	288E-400			Spare jaw			1	349
0288004516000	288E-450			Spare jaw			1	420
0288006116000	288E-610			Spare jaw			1	770
0288008016000	288E-800			Spare jaw			1	1450
0288009016000	288E-900			Spare jaw			1	1460

289-...

STEEL WIRE MESH CUTTER

- ▶ inductive hardened jaws on the cutter head
- ▶ head angled at 75°
- ▶ easy and precise readjusting with double eccentric screws
- ▶ according to DIN 5743
- ▶ limbs made of steel tube with plastic handles
- ▶ jaws made of special high grade tool steel



Code	Number	19 HRC Ø mm	40 HRC Ø mm	l/mm ┆	l/Inch ┆	Pieces ☞	Weight/g ⚖
0289008006000	289-800	9	8	790	31	1	3200
0289009006000	289-900	11	9	900	36	1	3460
0289008016000	289E-800	Spare jaw				1	860

4490

BAG OR WIRE TWISTER

- ▶ for fast and efficient closing of bags or connecting tyre levers
- ▶ with moulded plastic grip



Code	Number	l/mm ┆	Pieces ☞	Weight/g ⚖
4490000000000	4490	310	1	462

525-...

WIRE TWISTING PLIER

- ▶ for wire locking of metal fasteners
- ▶ serrated gripping for positive grip and side cutter
- ▶ for clockwise use and with automatic return
- ▶ jaws angled by 40°, for wires to Ø1,6mm
- ▶ gunmetal finish, head polished
- ▶ Chrome-Vanadium special steel



Code	Number	l/mm ┆	Pieces ☞	Weight/g ⚖
0525001503000	525-150	150	1	273
0525002303000	525-230	230	1	393

458

REVOLVING PUNCH AND EYELET PLIER

- for pre-punching and pressing of eyelets 458S-4,5, 458S-5,0, 458S-5,5
- bright nickel plated, with black ergonomically formed plastic handles
- high-strength special tool steel



Code	Number	l/mm	l/Inch	Pieces	Weight/g
0458000000000	458	210	8,5	1	346

458S-...

EYELETS

- for pressing with ELORA-No. 458
- nickel plated
- sheet metal



Code	Number	Contents	Ø	Pieces	Weight/g
0458000450000	458S-4,5	100 eyelets	4,5	1	20
0458000500000	458S-5,0	100 eyelets	5,0	1	26
0458000550000	458S-5,5	100 eyelets	5,5	1	26

460

REVOLVING PUNCH PLIER WITH LEVERAGE

- 70% power saving by leverage
- for punching thin and strong awnings, fabrics, leather, textiles and thin metal sheet
- punching hole diameter 2,0-2,5-3,0-3,5-4,0-4,5 mm
- bright nickel plated, with black ergonomic formed plastic handles
- high-strength special tool steel



Code	Number	l/mm	l/Inch	Pieces	Weight/g
0460000000000	460	250	10	1	464

461

REVOLVING PUNCH PLIER

- for punching thin and strong awnings, fabrics, leather, textiles and thin metal sheet
- punching hole diameter 2,0-2,5-3,0-3,5-4,0-4,5 mm
- nickel plated, with black ergonomic formed plastic handles
- high-strength special tool steel



Code	Number	l/mm	l/Inch	Pieces	Weight/g
0461000000000	461	210	8,5	1	328

402-...

SHAPE CUTTING LEVER TIN SNIP

- for figures, short and straight cuts
- with leverage
- self-opening due to mounted leaf spring, with lock
- blades with micro denticulation to maximize the safety factor against sliding
- blades additionally inductive hardened and ground
- nonslip 2C-handles with trap protection
- for metal sheet thickness of max. 1,2mm with a tensile strength of 600 N/mm²



Code	Number	Type of Cut	l/mm	l/Inch	Length of cutting edges mm	Pieces	Weight/g
0402002501001	402/1-L	left cutting	250	10	38	1	390
0402002501003	402/1-G	straight cutting	250	10	44	1	541
0402002501002	402/1-R	right cutting	250	10	38	1	555

402/1 S3

SHAPE CUTTING LEVER TIN SNIP SET

- 3 pcs.
- carton box packed
- for figures, short and straight cuts
- with leverage
- self-opening due to mounted leaf spring, with lock
- blades with micro denticulation to maximize the safety factor against sliding
- blades additionally inductive hardened and ground
- nonslip 2C-handles with trap protection
- for metal sheet thickness of max. 1,2 mm with a tensile strength of 600 N/mm²



Code	Number	Contents	Pieces	Weight/g
0402500031000	402/1 S3	Figure Snips 402/1-L, 402/1-R, 402/1-G	1	1689

483L / 483R

SHAPE CUTTING LEVER TIN SNIP

- for short, straight and figure cuts, small radius
- with leverage
- self-opening due to mounted leaf spring, with lock
- burr-free cut
- adjustable, bolted joints
- blades with micro denticulation to maximize the safety factor against sliding
- blades additionally inductive hardened and ground, 60-62 HRC
- with plastic handles and trap protection
- for metal sheet thickness of max. 1,8 mm with a tensile strength of 400 N/mm² or 1,2 mm with a tensile strength of 600 N/mm²
- high grade tool steel, forged



Code	Number	Type of Cut	l/mm	l/Inch	Length of cutting edges mm	Pieces	Weight/g
0483000016000	483L	left cutting	250	10	35	1	524
0483000026000	483R	right cutting	250	10	35	1	523

484L / 484R

IDEAL LEVER TIN SNIP

- for short, straight and figure cuts, big radius
- with leverage
- self-opening due to mounted leaf spring, with lock
- burr-free cut
- adjustable, bolted joint
- blades with micro denticulation to maximize the safety factor against sliding
- blades additionally inductive hardened and ground, 60-62 HRC
- with plastic handles and trap protection
- for metal sheet thickness of max. 1,8 mm with a tensile strength of 400 N/mm² or 1,2 mm with a tensile strength of 600 N/mm²
- high grade tool steel, forged



Code	Number	Type of Cut	l/mm	l/Inch	Length of cutting edges mm	Pieces	Weight/g
0484000016000	484L	left cutting	250	10	30	1	565
0484000026000	484R	right cutting	250	10	30	1	565

284-250

BERLIN PATTERN TIN SNIP

- for long straight cuts
- blades additionally inductive hardened and ground, 56-58 HRC
- adjustable, bolted joint
- black handles, PVC dip coated, trap protection, opening spring
- high grade tool steel, forged



Code	Number	l/mm	l/Inch	Length of cutting edges mm	Pieces	Weight/g
0284002506000	284-250	250	10	60	1	446

1483-...

SHAPE CUTTING TIN SNIP

- for short, straight and figure cuts, small radius
- blades additionally inductive hardened and ground, 56-59 HRC
- adjustable, bolted joint
- black handles, PVC dip coated, trap protection, opening spring
- for metal sheet thickness of max. 1,5 mm with a tensile strength of 400 N/mm² or 1 mm with 600 N/mm²
- high grade tool steel, forged



Code	Number	Type of Cut	l/mm	l/Inch	Length of cutting edges mm	Pieces	Weight/g
1483002506000	1483L-250	left cutting	250	10	42	1	501
1483012506000	1483R-250	right cutting	250	10	42	1	435

1484-...

IDEAL TIN SNIP

- for continuous cuts and figure cuts
- blades additionally inductive hardened and sharpened, 56-59 HRC
- adjustable, bolted joint
- black handles, PVC dip coated, trap protection, opening spring
- for metal sheet thickness of max. 1,5 mm with a tensile strength of 400 N/mm² or 1 mm with 600 N/mm²
- high grade tool steel, forged



Code	Number	Type of Cut	l/mm	l/Inch	Length of cutting edges mm	Pieces	Weight/g
1484002606000	1484L-260	left cutting	260	10,25	35	1	590
1484012606000	1484R-260	right cutting	280	10,25	35	1	590

488-...

PUNCH TIN SNIP

- for short, straight and figure cuts, big radius
- blades additionally inductive hardened and ground, 56-59 HRC
- adjustable, bolted joint
- black handles, PVC dip coated, trap protection, opening spring
- for metal sheet thickness of max. 1,5 mm with a tensile strength of 400 N/mm² or 1 mm with 600 N/mm²
- high grade tool steel, forged



Code	Number	Type of Cut	l/mm	l/Inch	Length of cutting edges mm	Pieces	Weight/g
0488002506000	488L-250	left cutting	250	10	42	1	506
0488002516000	488R-250	right cutting	250	10	42	1	435

497R-300

PELICAN TIN SNIP

- for long straight continuous cuts
- blades additionally inductive hardened and ground, 56-59 HRC
- adjustable, bolted joint
- black handles, PVC dip coated, trap protection, opening spring
- for metal sheet thickness of max. 1,8 mm with a tensile strength of 400 N/mm² or 1 mm with 600 N/mm²
- high grade tool steel, forged



Code	Number	Type of Cut	l/mm	l/Inch	Length of cutting edges mm	Pieces	Weight/g
0497003006000	497R-300	right cutting	300	12	60	1	839

401-...

AMERICAN TINMANS SHEAR

- for long straight cuts
- blades additionally inductive hardened and ground, 57-59 HRC
- adjustable, bolted joint
- high grade tool steel, forged
- ELORA-No. 401/1 with trap protection
- ELORA-No. 401/2 black handles, PVC dip coated
- trap protection



Code	Number	l/mm	l/Inch	Length of cutting edges mm	Pieces	Weight/g
0401001751001	401/1-175	175	7	40	1	294
0401002001001	401/1-200	200	8	45	1	338
0401002501001	401/1-250	250	10	65	1	515
0401003001001	401/1-300	300	12	80	1	680
0401003501001	401/1-350	350	14	90	1	868
0401001751002	401/2-175	175	7	40	1	307
0401002001002	401/2-200	200	8	45	1	376
0401002501002	401/2-250	250	10	65	1	561
0401003001002	401/2-300	300	12	80	1	705
0401003501002	401/2-350	350	14	90	1	868

498-...

UNIVERSAL SCISSORS

- for cutting thin metal sheet, wire, plastics, adhesive weights, carpet, paper, etc.
- self-opening, one-hand lock function
- plastic handles
- made of stainless steel



Code	Number	l/mm	l/Inch	Length of cutting edges mm	Pieces	Weight/g
0498000016000	498-1	140	5,5	31	1	73
0498000026000	498-2	190	7,5	42	1	108

498-5

UNIVERSAL SCISSORS, BENT

- for cutting thin metal sheet, wire, plastics, adhesive weights, carpet, paper, etc.
- bent head
- self-opening, one-hand lock function
- plastic handles
- made of stainless steel



Code	Number	l/mm	l/Inch	Length of cutting edges mm	Pieces	Weight/g
0498000056000	498-5	190	7,5	38	1	108

You will find wire snips on page 305



500H**HOLDER FOR ELORA-GRIP PLIERS**

- inserted into the holder ELORA grip pliers can be used as bench vise for simple works to screw on a work table or a work bench
- fits to all 8" and 10" ELORA grip pliers and ELORA-No. 510-280, 510-280A, 511-280 and 524
- black laquered



Code	Number	Span Width mm	l/mm	Pieces	Weight/g
050000003000	500H	0-50	110	1	200

500-...**GRIP PLIER WITH WIRE CUTTER, CURVED JAWS**

- for round and flat material
- with adjustment screw
- quick release lever with return spring
- forged, hardened and tempered half-round jaws
- nickel-plated
- jaws made of ELORA-Chrome-Vanadium 31 CrV 3 / 1.2208



Code	Number	Span Width mm	l/mm	l/Inch	Pieces	Weight/g
0500001253000	500-125	25	125	5	1	195
0500001803000	500-180	35	180	8	1	360
0500002503000	500-250	50	250	10	1	570
0500003003000	500-300	65	300	12	1	895

500P-...**PRISM GRIP PLIER**

- for round and flat material
- 3-point support for any material profile
- with adjustment screw
- quick release lever with return spring
- forged, hardened and tempered prism jaws
- nickel-plated
- jaws made of ELORA-Chrome-Vanadium 31 CrV 3 / 1.2208



Code	Number	Span Width mm	l/mm	l/Inch	Pieces	Weight/g
0500011803000	500P-180	25	180	8	1	280
0500012503000	500P-250	45	250	10	1	750
0500013003000	500P-300	45	300	12	1	975

500G-250**GRIP PLIER, STRAIGHT JAWS**

- for flat material
- with adjustment screw
- quick release lever with return spring
- forged, hardened and tempered straight jaws
- nickel-plated
- jaws made of ELORA-Chrome-Vanadium 31 CrV 3 / 1.2208



Code	Number	Span Width mm	l/mm	l/Inch	Pieces	Weight/g
0500202503000	500G-250	40	250	10	1	510

502-...

IDEAL GRIP PLIER

- ▶ for round, profile and flat material
- ▶ combined jaw shape
- ▶ with adjustment screw and release lever
- ▶ quick release lever with return spring
- ▶ nickel-plated
- ▶ jaws made of ELORA-Chrome-Vanadium 31 CrV 3 / 1.2208



Code	Number	Span Width mm	l/mm	l/Inch	Pieces	Weight/g
0502001803000	502-180	45	180	8	1	365
0502002503000	502-250	45	250	10	1	570

501

PARALLEL-GRIP PLIER

- ▶ for round and flat material
- ▶ plier mouth with swivelling jaws
- ▶ with adjustment screw
- ▶ quick release lever with return spring
- ▶ nickel-plated
- ▶ jaws made of ELORA-Chrome-Vanadium 31 CrV 3 / 1.2208



Code	Number	Span Width mm	l/mm	l/Inch	Pieces	Weight/g
0501000000000	501	45	250	10	1	575

508-...

LONG NOSE OR CROW NOSE PLIER

- ▶ to clamp or remove round, profile and flat material in narrow and deep sections for e.g. motors, control cabinets etc.
- ▶ long, slim jaws with burner hole
- ▶ quick release lever with return spring
- ▶ drop-forged, nickel-plated
- ▶ jaws made of 1045



Code	Number	Span Width mm	l/mm	l/Inch	Pieces	Weight/g
0508001653000	508-165	0-40	165	12	1	190
0508002353000	508-235	0-55	235	12	1	380
0508003003000	508-300	0-130	300	12	1	480

505-...

PARALLEL GRIP PLIER

- ▶ suitable for small round parts and bulky items
- ▶ for exceedingly high work pieces
- ▶ even for smaller round pieces
- ▶ clamp function
- ▶ parallel clamping surface with prism recess
- ▶ equal parallelism over the complete clamping range
- ▶ long slide (100-200 mm)
- ▶ jaws made of ELORA-Chrome-Vanadium 31 CrV 3 / 1.2208



Code	Number	Span Width mm	Radial mm	l/mm	l/Inch	Pieces	Weight/g
0505001003000	505-100	65	100	280	12.1/2	1	950
0505002003000	505-200	65	200	280	12.1/2	1	1100
0505000003000	505K	Protection cap set for parallel grip plier (for gentle tightening of sensitive surfaces)				1	5

512-180

SHEET METAL GRIP PLIER

- for clamping, bending and folding of thin and soft metal sheet
- 80 mm width, parallel joint jaws
- quick release lever with return spring
- nickel-plated
- drop-forged basis jaws
- tin jaws mad of C1045, hardened



Code	Number	Span Width mm	l/mm	l/Inch	Pieces	Weight/g
0512101803000	512-180	0-45	180	7	1	470

507-165/165S

C-CLAMP GRIP PLIER

- to use instead of screw clamps
- movable steel jaws in the S version
- quick release lever with return spring
- nickel-plated
- jaws made of C1045



Code	Number	Span Width mm	Radial mm	l/mm	l/Inch	Pieces	Weight/g
0507101653000	507-165	0-50	50	175	7	1	235
0507101663000	507-165S	0-40	42	175	7	1	260

507-280/280S

C-CLAMP GRIP PLIER

- to use instead of screw clamps
- movable steel jaws in
- quick release lever with
- nickel-plated
- jaws made of ELORA
Vanadium 31 CrV 3 /



Code	Numl							
0507102803000	507-280	0-90	77	280	11	1	750	
0507102813000	507-280S	0-90	77	280	11	1	780	

507-...

C-CLAMP GRIP PLIER

- to use instead of screw clamps
- movable steel jaws in the S version
- quick release lever with return spring
- nickel-plated
- jaws made of ELORA-Chrome-
Vanadium 31 CrV 3 / 1.2208
- extension made of ST37-2



Code	Number	Span Width mm	Radial mm	l/mm	l/Inch	Pieces	Weight/g
0507104603000	507-460	0-220	265	460	18	1	1090
0507106003000	507-600	0-295	400	600	24	1	1415
0507106013000	507-600S	0-295	400	600	24	1	1505

507A-...

ALUMINIUM C-CLAMP GRIP PLIER

- ▶ for clamping of profile material with high racks and for work on bulky work pieces
- ▶ the light alloy avoids the adhering of welding beads
- ▶ approx. 40% weight reduction for better handling in continuous operation
- ▶ quick release lever with return spring
- ▶ nickel-plated
- ▶ jaws made of heavy-duty light metal alloy



Code	Number	Span Width mm	Radial mm	l/mm	l/Inch	Pieces	Weight/g
0507203003000	507A-300	0-90	70	300	12	1	640
0507203603000	507A-360	0-180	140	360	14	1	870

509-500

C-CLAMP GRIP PLIER

- ▶ for clamping of profile material with high racks and for work on bulky work pieces, especially appropriate for metal construction and car body work
- ▶ quick release lever with return spring
- ▶ nickel-plated
- ▶ jaws made of ELORA-Chrome-Vanadium 31 CrV 3 / 1.2208



Code	Number	Span Width mm	Radial mm	l/mm	l/Inch	Pieces	Weight/g
0509005003000	509-500	0-270	300	500	20	1	1785

510TG-280

WELDER'S GRIP PLIER

- ▶ for clamping of profiles and straps, especially appropriate to connect two working pieces of the same thickness
- ▶ the large opening allows a good overview during welding
- ▶ quick release lever with return spring
- ▶ drop-forged, nickel-plated
- ▶ jaws made of annealed cast iron



Code	Number	Span Width mm	Radial mm	l/mm	l/Inch	Pieces	Weight/g
0510302803000	510TG-280	0-70	80	280	11	1	935

510-280

WELDER'S GRIP PLIER

- for clamping of profiles and straps, especially appropriate to connect two working pieces of the same thickness
- the light metal alloy avoids the adhering of welding beads
- the large opening allows a good overview during welding
- quick release lever with return spring
- nickel-plated
- jaws made of heavy-duty light metal alloy



Code	Number	Span Width mm	Radial mm	l/mm	l/Inch	Pieces	Weight/g
0510202803000	510-280	0-60	80	280	11	1	790

511-280

PIPE WELDERS GRIP PLIER

- for centered clamping of two close-fitting pipes for welding, drilling, soldering etc.
- the large opening allows a good overview during welding
- quick release lever with return spring
- nickel-plated
- jaws made of ELORA-Chrome-Vanadium 31 CrV 3 / 1.2208



Code	Number	Span Width mm	Radial mm	l/mm	l/Inch	Pieces	Weight/g
0511102803000	511-280	10-90	90	280	11	1	935

524-...

CHAIN GRIP PLIER

- for clamping of any shaped profile, especially appropriate in narrow and difficult to reach areas like oil filters, exhaust pipes, etc.
- ELORA-No. 524E is an extension as well as spare chain at the same time
- quick release lever with return spring
- nickel-plated
- jaws made of ELORA-Chrome-Vanadium 31 CrV 3 / 1.2208



Code	Number	for ø up to mm	l/mm	Pieces	Weight/g
0524002503000	524-250	150	250	1	930
0524400003000	524-E	spare and extension chain	480	1	315

500-S4

GRIP PLIER SET

- 4 pcs.
- carton box packed



Code	Number	Contents	Pieces	Weight/g
0500500401000	500-S4	500-250 Rip Plier with Wire Cutter, curved Jaws 508-165 Long Nose- or Crow Nose Plier 507-280 C-Clamp Grip Plier 519 Micro Grip Plier	1	1760

Advantages of the elora-axial-grip-pliers:

- ergonomical design. Round contours for operator's comfort.
- small size and linear motion allows use for many shapes even in awkward sections.
- easy push-button release.
- one-hand-operating.

Application:

Axial Grip Pliers are suitable for body repair jobs and welding work. No provisional welding required to hold body parts for assembly.

519
MICRO GRIP PLIER

- high grade, hardened and tempered aluminium alloy, 120 g light only
- ergonomic design with rounded shape
- one-hand operation
- axial movement of the moveable jaw
- brass screw is also the moveable jaw
- brass screw/ moveable jaw made of solid brass
- knurled knob of the brass adjust screw
- anodized body



Code	Number	Span Width mm	l/mm	Pieces	Weight/g
0519000003000	519	12	92	1	130

513
AXIAL GRIP PLIER

- for clamping of overlapping metal sheets during spot welding, makes it possible to weld 4 clean spots without moving the plier, for use on doorways, side pieces, etc.
- slim shape with quick release lever
- jaw adjustment: 0-15 mm
- jaw wideness: 57 mm
- bright nickel-plated, black jaws
- jaws made of high-strength steel



Code	Number	l/mm	Pieces	Weight/g
0513000003000	513	195	1	551

514

AXIAL GRIP PLIER

- for clamping of metal sheet with high racks, especially appropriate for work on side panels and rear parts, U-shaped body profiles etc. and for welding in folds on VW, Audi, Opel, Ford, various Japanese cars
- slim shape with quick release lever
- jaw adjustment: 0-15 mm
- jaw wideness: 45 mm
- bright nickel-plated, black jaws
- jaws made of high-strength steel



Code	Number	l/mm	Pieces	Weight/g
0514000003000	514	235	1	552

515

AXIAL GRIP PLIER

- for clamping of U-profiles and U-shaped body profiles, especially appropriated for adjusting rear parts and rear side panels
- slim shape with quick release lever
- jaw adjustment: 0-15 mm
- jaw wideness: 18 mm
- bright nickel-plated, black jaws
- jaws made of high-strength steel



Code	Number	l/mm	Pieces	Weight/g
0515000003000	515	210	1	455

516

AXIAL GRIP PLIER

- for the rectangular clamping of two metal sheet pieces of the same thickness, for welding from fillet straight to the metal sheet edge
- slim shape with quick release lever
- jaw adjustment: 0-10 mm
- jaw wideness: 50 mm
- bright nickel-plated, black jaws
- jaws made of high-strength steel



Code	Number	l/mm	Pieces	Weight/g
0516000003000	516	200	1	530

517

AXIAL GRIP PLIER

- for clamping of U-profiles and U-shaped body profiles, especially appropriate for adjusting door sills, wheel housings, roofs and side panels for afterwards spot welding between the plier jaws
- slim shape with quick release lever
- jaw adjustment: 0-15 mm
- jaw wideness: 45 mm
- bright nickel-plated, black jaws
- jaws made of high-strength steel



Code	Number	l/mm	Pieces	Weight/g
0517000003000	517	220	1	494

518

AXIAL GRIP PLIER

- for work in tight curves, especially appropriate for work on doorways, wheel housings, tail gates, bonnets and rear side panels, without moving the plier
- slim shape with quick release lever
- jaw adjustment: 0-18 mm
- jaw wideness: 18 mm
- bright nickel-plated, black jaws
- jaws made of high-strength steel



Code	Number	l/mm	Pieces	Weight/g
0518000003000	518	195	1	443

519S-6

AXIAL GRIP PLIER SET

- 6 pcs.
- carton box packed



Code	Number	Contents	Pieces	Weight/g
0519500063000	519-S6	Axial Grip Pliers 513, 514, 515, 516, 517, 518	1	2740

473-J 1-4

CIRCLIP PLIER FOR INTERNAL RETAINING RING

- for internal retaining rings acc. to DIN 472, DIN 984
- straight jaws
- chrome plated, polished joint, chequered handles
- ELORA-Chrome-Vanadium 31 CrV 3 / 1.2208
- according to DIN 5256 Form C



Code	Number	for circlips from ... to Ø mm	l/mm	l/Inch	Pieces	Weight/g
0473010082000	473-J1	8-25	140	5,5	1	102
0473010192000	473-J2	19-60	170	7	1	182
0473010402000	473-J3	40-100	220	9	1	256
0473010852000	473-J4	85-165	320	13	1	481

473-J 11-41

CIRCLIP PLIER FOR INTERNAL RETAINING RING

- for internal retaining rings acc. to DIN 472, DIN 984
- jaws bent at 90°
- chrome plated, polished joint, chequered handles
- ELORA-Chrome-Vanadium 31 CrV 3 / 1.2208
- according to DIN 5256 Form D



Code	Number	for circlips from ... to Ø mm	l/mm	l/Inch	Pieces	Weight/g
0473020082000	473-J11	8-25	140	5,5	1	104
0473020192000	473-J21	19-60	170	7	1	177
0473020402000	473-J31	40-100	220	9	1	262
0473020852000	473-J41	85-165	320	13	1	492

474-A1-4

CIRCLIP PLIER FOR EXTERNAL RETAINING RING

- for external retaining rings acc. to DIN 471, DIN 983
- straight jaws, self-opening due to mounted double leaf spring
- chrome plated, polished joint, chequered handles
- ELORA-Chrome-Vanadium 31 CrV 3 / 1.2208
- according to DIN 5254 Form A



Code	Number	for circlips from ... to Ø mm	l/mm	l/Inch	Pieces	Weight/g
0474010102000	474-A1	10-25	135	5	1	110
0474010192000	474-A2	19-60	170	7	1	177
0474010402000	474-A3	40-100	220	9	1	266
0474010852000	474-A4	85-165	320	13	1	492

474-A11-41

CIRCLIP PLIER FOR EXTERNAL RETAINING RING

- for external retaining rings acc. to DIN 471, DIN 983
- jaws bent at 90°, self-opening due to mounted double leaf spring
- chrome plated, polished joint, chequered handles
- ELORA-Chrome-Vanadium 31 CrV 3 / 1.2208
- according to DIN 5254 Form B



Code	Number	for circlips from ... to Ø mm	l/mm	l/Inch	Pieces	Weight/g
0474020102000	474-A11	10-25	135	5	1	113
0474020192000	474-A21	19-60	170	7	1	180
0474020402000	474-A31	40-100	220	9	1	276
0474020852000	474-A41	85-165	320	13	1	502

469

CIRCLIP PLIER FOR EXTERNAL RETAINING RINGS

- for external retaining rings without holes
- straight jaws, self-opening due to mounted double leaf spring
- chrome-plated, polished joint, chequered handles
- ELORA-Chrome-Vanadium 31 CrV3 / 1.2208



Code	Number	l/mm	l/Inch	Pieces	Weight/g
0469000000000	469	175	7	1	182

404-S41

CIRCLIP PLIER SET

- 4 pcs.
- carton box packed
- chequered handles
- chrome-plated, polished joint



Code	Number	Contents	Pieces	Weight/g
0404500411000	404-S41	Circlip Plier for Internal Retaining Ring 473-J 2; 473-J 21 Circlip Plier for External Retaining Ring 474-A2; 474-A21	1	801

404-S8

CIRCLIP PLIER SET

- 8 pcs.
- assortment in convenient plastic case
- chrome plated, polished joint, chequered handles



Code	Number	Contents	Pieces	Weight/g
0404500801000	404-S8	Circlip Plier for Internal Retaining Ring 473-J 1; 473-J 11; 473-J 2; 473-J 21 Circlip Plier for External Retaining Ring 474-A1; 474-A11; 474-A2; 474-A21	1	1537

You will find the matching OMS-20 module on page no. 40

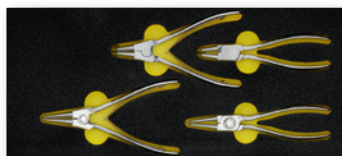

You will find the matching MS-26 module on page no. 50



383-J1-J4

CIRCLIP PLIER FOR INTERNAL RETAINING RING

- for internal retaining rings acc. to DIN 472, DIN 984
- straight jaws
- gunmetal-finish, ground joint
- red dip insulated handles
- ELORA-Chrome-Vanadium 31 CrV 3 / 1.2208
- according to DIN 5256 Form C



Code	Number	for circlips from ... to Ø mm	l/mm	l/Inch	Pieces	Weight/g
0383010085100	383-J1	8-25	140	5,5	1	119
0383010195100	383-J2	19-60	180	7	1	191
0383010405100	383-J3	40-100	220	9	1	276
0383010855100	383-J4	85-165	320	13	1	516

383-J11-J41

CIRCLIP PLIER FOR INTERNAL RETAINING RING

- for internal retaining rings acc. to DIN 472, DIN 984
- jaws bent at 90°
- gunmetal-finish, ground joint
- red dip insulated handles
- ELORA-Chrome-Vanadium 31 CrV 3 / 1.2208
- according to DIN 5256 Form D



Code	Number	for circlips from ... to Ø mm	l/mm	l/Inch	Pieces	Weight/g
0383020085100	383-J11	8-25	130	5	1	109
0383020195100	383-J21	19-60	170	7	1	189
0383020405100	383-J31	40-100	210	8,5	1	274
0383020855100	383-J41	85-165	310	12,5	1	514

384-A0-A4

CIRCLIP PLIER FOR EXTERNAL RETAINING RING

- for external retaining rings acc. to DIN 471, DIN 983
- straight jaws, self-opening due to mounted spiral spring
- gunmetal-finish, ground joint
- red dip insulated handles
- ELORA-Chrome-Vanadium 31 CrV 3 / 1.2208
- according to DIN 5254 Form A



Code	Number	for circlips from ... to Ø mm	l/mm	l/Inch	Pieces	Weight/g
0384010035100	384-A0	3-10	140	5,5	1	114
0384010105100	384-A1	10-25	140	5,5	1	108
0384010195100	384-A2	19-60	180	7	1	183
0384010405100	384-A3	40-100	220	9	1	275
0384010855100	384-A4	85-165	320	13	1	512

384-A01-A41

CIRCLIP PLIER FOR EXTERNAL RETAINING RING

- for external retaining rings acc. to DIN 471, DIN 983
- jaws bent at 90°, self-opening due to mounted spiral spring
- gunmetal-finish, ground joint
- red dip insulated handles
- ELORA-Chrome-Vanadium 31 CrV 3 / 1.2208
- according to DIN 5254 Form B

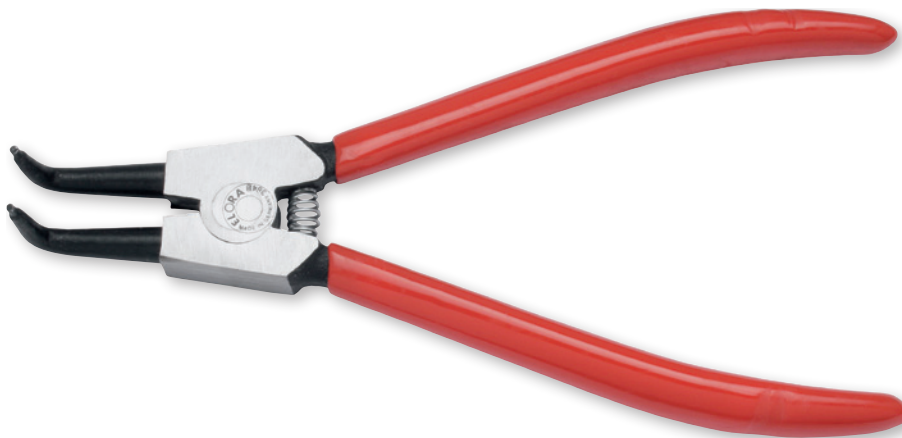

Code	Number	for circlips from ... to Ø mm	l/mm	l/Inch	Pieces	Weight/g
0384020035100	384-A01	3-10	130	5	1	110
0384020105100	384-A11	10-25	130	5	1	115
0384020195100	384-A21	19-60	170	7	1	178
0384020405100	384-A31	40-100	210	8,5	1	283
0384020855100	384-A41	85-165	310	12,5	1	511

304-S4

CIRCLIP PLIER SET

- 4 pcs.
- carton box packed
- red dip insulated handles



Code	Number	Contents	Pieces	Weight/g
0304500401000	304-S4	Circlip Plier for Internal Retaining Ring 383-J 2; 383-J 21 Circlip Plier for External Retaining Ring 384-A2; 384-A21	1	799

08

You will find the matching MS-25 module on page no. 50

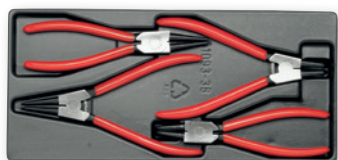

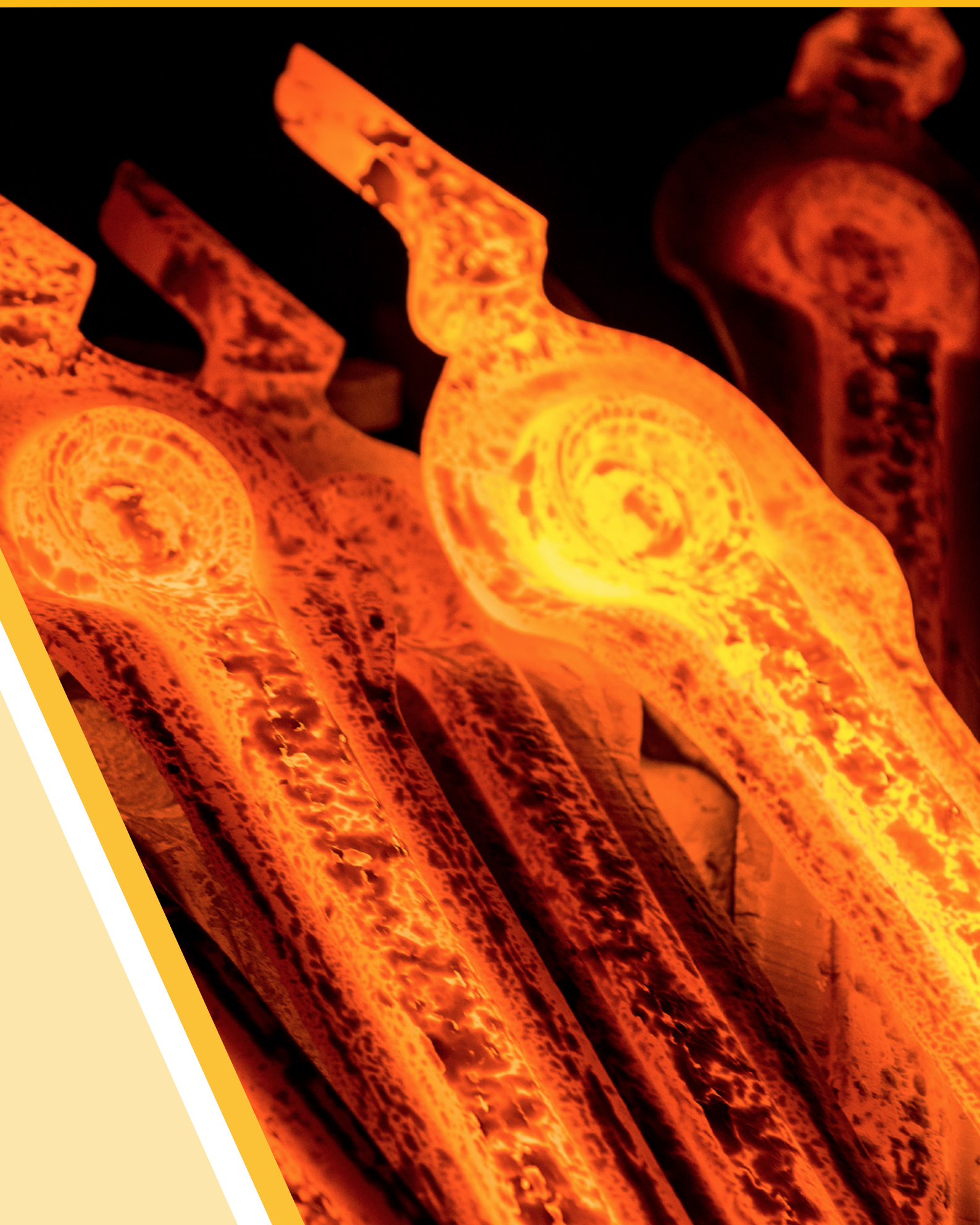



STRIKING TOOLS

Hammers and Club Hammers _____	Page 368
Soft faced Hammers _____	Page 372
Hand striking Tools _____	Page 376
Drift, Center, Pin Punches _____	Page 379
Bending Bars, Nail Lifters and Wrecking Bars _____	Page 386
Bench Vices and Accesories _____	Page 390

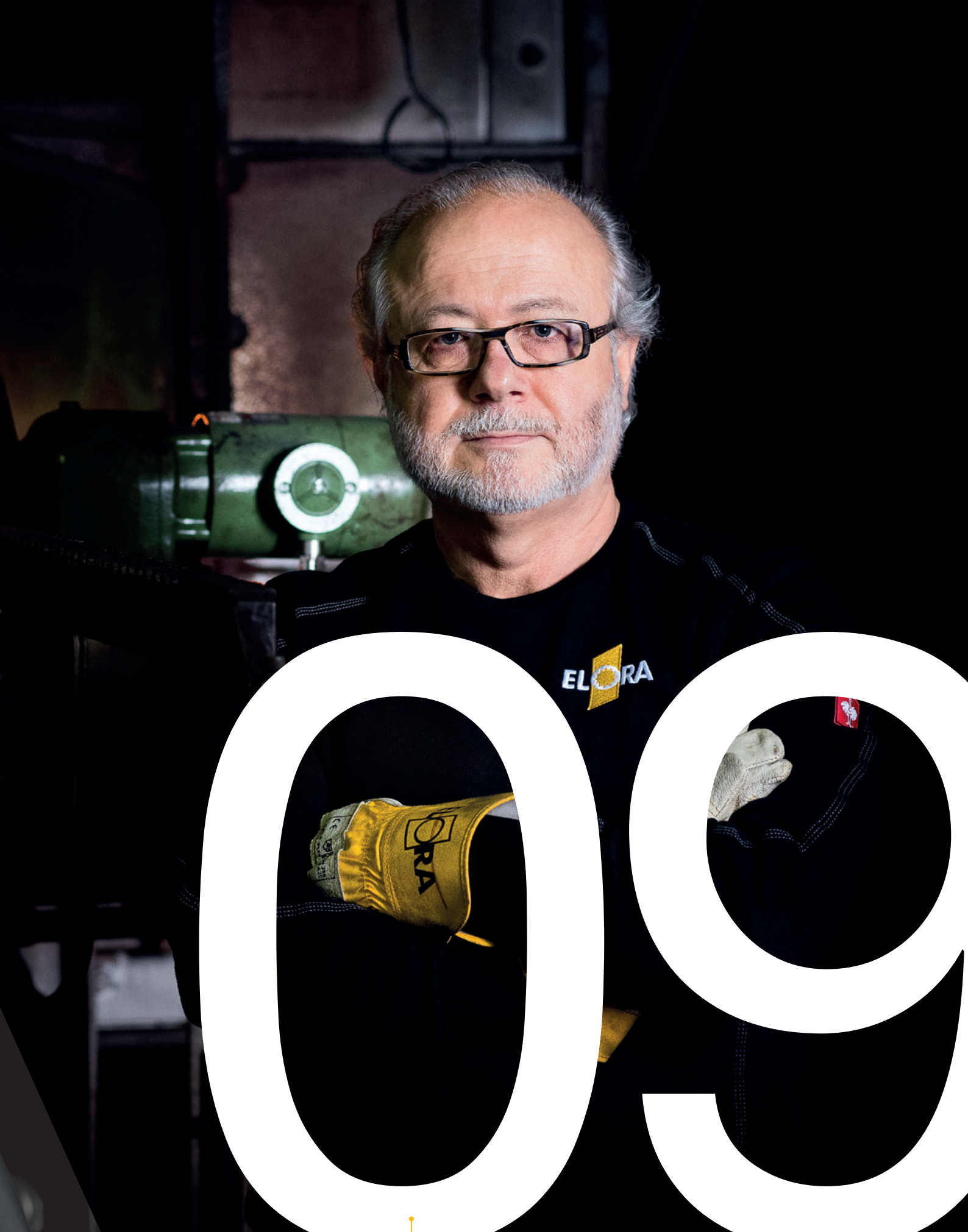

All the necessary production steps, from the blanks to the final products, are carried out in our nine in-house production departments. Day in, day out ...

1665-...

ENGINEER'S HAMMER, GERMAN PATTERN

- drop forged hammer head with safety collar
- inductive hardened and coated
- face and peen polished
- ash handle with shaft protection bush made of nylon
- mechanically fixed with a steel ring wedge and epoxide resin
- ELORA-high grade tool steel C45 / 1.0503
- hammer head according to DIN 1041, handle according to DIN 5111



Code	Number	g	l/mm	Pieces	Weight/g
1665001007000	1665-100	100	260	2	145
1665002007000	1665-200	200	275	2	250
1665003007000	1665-300	300	300	2	370
1665004007000	1665-400	400	310	2	460
1665005007000	1665-500	500	320	2	590
1665006007000	1665-600	600	325	2	730
1665008007000	1665-800	800	350	2	910
1665010007000	1665-1000	1000	355	2	1170
1665015007000	1665-1500	1500	380	2	1700
1665020007000	1665-2000	2000	400	2	2285

1665ST-...

HANDLE FOR ENGINEER'S HAMMER

- for ELORA-No. 1665-..., German pattern
- ash handle according to DIN 5111



Code	Number	g	l/mm	Pieces	Weight/g
1665001008000	1665ST-100	100	250	6	50
1665002008000	1665ST-200	200	275	6	57
1665003008000	1665ST-300	300	300	6	71
1665004008000	1665ST-400	400	310	6	100
1665005008000	1665ST-500	500	320	6	105
1665006008000	1665ST-600	600	325	6	127
1665008008000	1665ST-800	800	350	2	149
1665010008000	1665ST-1000	1000	355	2	157
1665015008000	1665ST-1500	1500	380	2	185
1665020008000	1665ST-2000	2000	400	2	285

1665KL-...

WEDGE FOR ENGINEER'S HAMMER

- for ELORA-No. 1665-..., German pattern

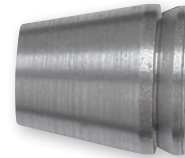

Code	Number	g	Ø	Pieces	Weight/g
1665401000000	1665KL-100	100	7	6	1
1665402000000	1665KL-200	200	8	6	2
1665403000000	1665KL-300	300	9	6	2
1665404000000	1665KL-400	400	10	6	3
1665405000000	1665KL-500	500	12	6	4
1665406000000	1665KL-600	600	13	6	6
1665408000000	1665KL-800	800	14	6	7
1665410000000	1665KL-1000	1000	15	6	8
1665415000000	1665KL-1500	1500	15	6	8
1665420000000	1665KL-2000	2000	16	6	11

1665-K...

ENGINEER'S HAMMER, GERMAN PATTERN

- vibration-free
- drop forged hammer head with safety collar
- inductive hardened and coated
- face and peen polished
- 3 component high security handle with nonslip rubber grip and a core made of aluminium alloy
- shaft protection bush made of nylon
- mechanically fixed with a steel ring wedge and epoxide resin
- ELORA-high grade tool steel C45 / 1.0503
- hammer head according to DIN 1041



Code	Number	g	l/mm	Pieces	Weight/g
1665003007700	1665-K300	300 g	304	2	467
1665005007700	1665-K500	500 g	325	2	751
1665010007700	1665-K1000	1000 g	363	2	1372

1670-...

ENGINEER'S HAMMER, ENGLISH PATTERN

- drop forged hammer head
- inductive hardened and coated
- face and peen polished
- ash handle
- mechanically fixed with a ring steel wedge and epoxide resin
- ELORA-high grade tool steel C45 / 1.0503



Code	Number	lb.	l/mm	Pieces	Weight/g
1670100237000	1670-1/2	1/2	295	2	310
1670100287000	1670-3/4	3/4	315	2	465
1670100347000	1670-1	1	335	2	555
1670100387000	1670-1.1/2	1.1/2	365	2	825
1670100497000	1670-2	2	375	2	1025

1670ST-...

HANDLE FOR ENGINEER'S HAMMER

- for ELORA-No. 1670-..., English pattern
- ash handle according to DIN 5111



Code	Number	lb.	l/mm	Pieces	Weight/g
1670100238000	1670ST-1/2	1/2	295	6	81
1670100288000	1670ST-3/4	3/4	315	6	98
1670100348000	1670ST-1	1	335	6	105
1670100388000	1670ST-1.1/2	1.1/2	365	2	132
1670100498000	1670ST-2	2	375	2	150

1670KL-...

WEDGE FOR ENGINEER'S HAMMER

- for ELORA-No. 1670-..., English pattern

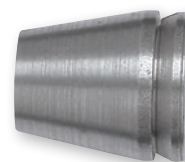

Code	Number	lb.	Ø	Pieces	Weight/g
1670400230000	1670KL-1/2	1/2	8	6	2
1670400280000	1670KL-3/4	3/4	10	6	3
1670400340000	1670KL-1	1	12	6	6
1670400380000	1670KL-1.1/2	1.1/2	13	6	7
1670400490000	1670KL-2	2	15	6	8

1672-...

CLUB HAMMER, GERMAN PATTERN

- drop forged hammer head with safety collar
- inductive hardened and coated
- faces polished
- ash handle with shaft protection bush made of nylon
- mechanically fixed with a steel ring wedge and epoxide resin
- ELORA-high grade tool steel C45 / 1.0503
- hammer head according to DIN 6475, handle according to DIN 5135



Code	Number	g	l/mm Ø	Pieces	Weight/g
1672010007000	1672-1000	1000 g	260	2	1180
1672012507000	1672-1250	1250 g	260	2	1430
1672015007000	1672-1500	1500 g	280	2	1690
1672020007000	1672-2000	2000 g	300	2	2200

You will find the matching OMS-12 module on page no. 40



You will find the matching OMS-8 module on page no. 41



1672ST-...

HANDLE FOR CLUB HAMMER

- for ELORA-No. 1672-..., German pattern
- ash handle according to DIN 5135



Code	Number	g	l/mm	Pieces	Weight/g
1672401008000	1672ST-1000	1000	260	6	82
1672412508000	1672ST-1250	1250	260	6	86
1672415008000	1672ST-1500	1500	280	6	115
1672402008000	1672ST-2000	2000	300	6	134

1672KL-...

WEDGE FOR CLUB HAMMER

- for ELORA-No. 1672-..., German pattern

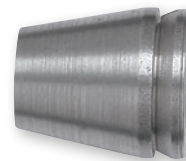

Code	Number	g	Ø	Pieces	Weight/g
1672410000000	1672KL-1000	1000	14	6	7
1672412500000	1672KL-1250	1250	15	6	8
1672415000000	1672KL-1500	1500	15	6	8
1672420000000	1672KL-2000	2000	16	6	11

1672-K...

CLUB HAMMER, GERMAN PATTERN

- vibration-free
- drop forged hammer head with safety collar
- inductive hardened and coated
- faces polished
- 3 component high safety handle with nonslip rubber grip and a core made of aluminium alloy
- shaft protection bush made of nylon
- mechanically fixed with a steel ring wedge and epoxide resin
- ELORA-high grade tool steel C45 / 1.0503
- hammer head according to DIN 6475



Code	Number	g	l/mm	Pieces	Weight/g
1672008007700	1672-K800	800	260	2	1031
1672010007700	1672-K1000	1000	260	2	1215
1672012507700	1672-K1250	1250	260	2	1416
1672015007700	1672-K1500	1500	282	2	1816

1673-...

SLEDGE HAMMER, GERMAN PATTERN

- forged hammer head
- inductive hardened and coated
- face and peen polished
- ash handle
- mechanically fixed with a steel ring wedge
- ELORA-high grade tool steel C45 / 1.0503
- hammer head according to DIN 1042, handle according to DIN 5112



Code	Number	g	l/mm	Pieces	Weight/g
1673030007000	1673-3000	3000	900	1	3350
1673040007000	1673-4000	4000	900	1	4480
1673050007000	1673-5000	5000	900	1	5520
1673060007000	1673-6000	6000	900	1	6420
1673080007000	1673-8000	8000	900	1	8300
1673100007000	1673-10000	10000	900	1	9800

1673ST-...

HANDLE FOR SLEDGE HAMMER

- for ELORA-No. 1673-..., German pattern
- ash handle according to DIN 5112



Code	Number	g	l/mm	Pieces	Weight/g
1673440008000	1673ST-4000	4000	900	2	625
1673450008000	1673ST-5000	5000	900	2	670
1673460008000	1673ST-6000	6000	900	2	700
1673480008000	1673ST-8000	8000	900	2	800
1673410008001	1673ST-10000	10000	900	2	800

1673KL-...

WEDGE FOR SLEDGE HAMMER

- for ELORA-No. 1673-..., German pattern

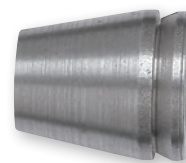

Code	Number	g	Ø	Pieces	Weight/g
1673430008010	1673KL-3000	3000	20	6	24
1673440008010	1673KL-4000	4000	20	6	24
1673450008010	1673KL-5000	5000	20	6	24
1673460008010	1673KL-6000	6000	20	6	24
1673480008010	1673KL-8000	8000	20	6	24
1673410008011	1673KL-10000	10000	20	6	24

1678

CARPENTER'S HAMMER

- drop forged hammer head
- black, nonslip plastic handle
- head coated and mechanically fixed
- steel tube handle
- head made from high grade tool steel C45 / 1.0503



Code	Number	l/mm	Pieces	Weight/g
1678000000000	1678	320	2	600

1680-330

CLAW HAMMER

- drop forged hammer head
- black, nonslip plastic handle
- coated head, face and claw polished
- steel tube handle
- head made of high grade tool steel C45 / 1.0503



Code	Number	Face Ø mm	l/mm	Pieces	Weight/g
1680000000000	1680-330	28	330	2	765

331

WELDER'S CHIPPING HAMMER

- with steel tube handle
- coated



Code	Number	l/mm	Pieces	Weight/g
0331000005100	331	290	1	552

1620-...
RUBBER Mallet

- with 2 flat faces and ash handle
- according to DIN 5128-90, 90 Shore A
- spare heads on request



Code	Number	Head Ø mm	Head-Length mm	l/mm	Pieces	Weight/g
1620000557000	1620-55	55	90	320	2	350
1620000657000	1620-65	65	115	340	2	520
1620000757000	1620-75	75	130	380	2	750
1620000907000	1620-90	90	140	380	2	1130

1660-...
SOFT FACED HAMMER

- face holder made of cast zinc
- exchangeable faces made of impact resistant Cellulose-Acetate
- ash handle
- DIN 53505, 65 Shore D

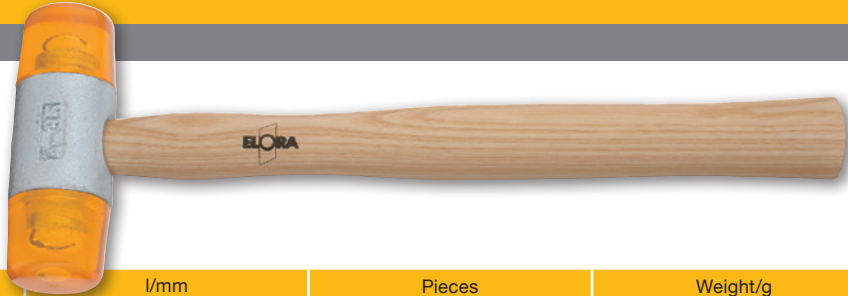

Code	Number	Head Ø mm	l/mm	Pieces	Weight/g
1660000220000	1660-22	22	250	2	145
1660000270000	1660-27	27	265	2	230
1660000320000	1660-32	32	280	2	310
1660000350000	1660-35	35	290	2	405
1660000400000	1660-40	40	320	2	570
1660000500000	1660-50	50	340	2	845
1660000600000	1660-60	60	340	2	1345

1660E-...
SPARE PLASTIC FACE

- for ELORA-No. 1660-...
- made of impact resistant Cellulose-Acetate



Code	Number	Head Ø mm	Pieces	Weight/g
1660010220000	1660E- 22	22	6	6
1660010270000	1660E- 27	27	6	14
1660010320000	1660E- 32	32	6	22
1660010350000	1660E- 35	35	6	28
1660010400000	1660E- 40	40	6	35
1660010500000	1660E- 50	50	6	68
1660010600000	1660E- 60	60	6	106

1660KL-...
WEDGE FOR SOFT FACED HAMMER

- for ELORA-No. 1660-...



Code	Number	g	Ø	Pieces	Weight/g
1660410220000	1660KL-22	22	8	6	2
1660410270000	1660KL-27	27	10	6	3
1660410320000	1660KL-32	32	10	6	3
1660410350000	1660KL-35	35	10	6	5
1660410400000	1660KL-40	40	12	6	5
1660410500000	1660KL-50	50	13	6	6
1660410600000	1660KL-60	60	13	6	6

1660ST-...
HANDLE FOR SOFT FACED HAMMER

- for ELORA-No. 1660-1661-...
- ash wood



Code	Number	Ø	l/mm	Pieces	Weight/g	Code	Number	Ø	l/mm	Pieces	Weight/g
1660400228000	1660ST-22	22	250	6	44	1660400408000	1660ST-40	40	320	6	82
1660400278000	1660ST-27	27	265	6	51	1660400508000	1660ST-50	50	340	6	90
1660400328000	1660ST-32	32	280	6	55	1660400608000	1660ST-60	60	340	6	100
1660400358000	1660ST-35	35	290	6	58						

1661-...

PLASTIC HAMMER

- face holder made of cast zinc
- exchangeable faces made of impact resistant Desmopan
- ash handle
- DIN 53505, 55 Shore D



Code	Number	Head Ø mm	l/mm	Pieces	Weight/g
1661000220000	1661-22	22	250	2	142
1661000320000	1661-32	32	280	2	330
1661000400000	1661-40	40	320	2	535
1661000500000	1661-50	50	335	2	855

1661E-...

SPARE PLASTIC FACE

- for ELORA-No. 1661-...
- wear- and break-resistant material Desmopan



Code	Number	Head Ø mm	Pieces	Weight/g
1661010220000	1661E- 22	22	6	14
1661010320000	1661E- 32	32	6	42
1661010400000	1661E- 40	40	6	74
1661010500000	1661E- 50	50	6	130

1690E-...

SPARE NYLON FACE

- for ELORA-No. 1690-...
- wear- and break-resistant material Nylon



Code	Number	Head Ø mm	Pieces	Weight/g
1690010206000	1690E- 20	20	6	6
1690010256000	1690E- 25	25	6	10
1690010306000	1690E- 30	30	6	18
1690010356000	1690E- 35	35	6	24
1690010406000	1690E- 40	40	6	32
1690010456000	1690E- 45	45	6	40
1690010506000	1690E- 50	50	2	55
1690010606000	1690E- 60	60	2	95
1690010706000	1690E- 70	70	2	130
1690010806000	1690E- 80	80	2	200

1690-...

DEAD-BLOW NYLON SOFT FACED HAMMER

- specially appropriated for targeted strikes (automobile industries, moulds and tool making)
- for non-rebounding strikes without losing power of impact and material gently work
- strong steel center section with holding pins for the spare nylon faces
- mass of steel shot in the hammer head exactly fine-tuned (mass inertia principle)
- nylon striking faces, exchangeable
- hickory handle
- DIN 53505, 73 Shore D



Code	Number	Head Ø mm	l/mm	Pieces	Weight/g	Code	Number	Head Ø mm	l/mm	Pieces	Weight/g
1690000206000	1690-20	20	305	2	230	1690000456000	1690-45	45	365	2	850
1690000256000	1690-25	25	305	2	310	1690000506000	1690-50	50	360	1	1030
1690000306000	1690-30	30	330	2	430	1690000606000	1690-60	60	360	1	1750
1690000356000	1690-35	35	330	2	550	1690000706000	1690-70	70	380	1	2290
1690000406000	1690-40	40	350	2	720	1690000806000	1690-80	80	380	1	3200

1600-...

HAMMER HOLDER

- 1600-1H and 1600-2H:
for presentation of hammers on perforated board
- 1600-3H:
for presentation of club hammers on perforated board



Code	Number	l/mm ┌───┐	Pieces ☞	Weight/g ⚖	
1600000017000	1600-1H	200	1	290	
1600000027000	1600-2H	300	1	365	
1600000037000	1600-3H	200	1	445	



260-...

FLAT CHISEL, FLAT OVAL

- for metal work
- completely hardened and tempered
- striking head inductive tempered
- working edge sharpened and oiled
- shaft black coated
- ELORA-Chrome-Vanadium 59CrV4 / 1.2242
- according to DIN 6453



Code	Number	l/mm	Width of Edge mm	Profile mm	Pieces	Weight/g
0260001006000	260-100	100	15	14 x 9	5	78
0260001256000	260-125	125	15	14 x 9	5	140
0260001506000	260-150	150	18	17 x 11	5	180
0260001756000	260-175	175	21	20 x 12	5	280
0260002006000	260-200	200	24	23 x 13	5	405
0260002506000	260-250	250	25	23 x 13	5	505
0260003006000	260-300	300	26	23 x 13	5	605
0260004006000	260-400	400	32	26 x 13	5	910

261-...

CAPE CHISEL, FLAT OVAL

- for metal work
- completely hardened and tempered
- striking head inductive tempered
- working edge sharpened and oiled
- shaft black coated
- ELORA-Chrome-Vanadium 59CrV4 / 1.2242
- according to DIN 6453



Code	Number	l/mm	Width of Edge mm	Profile mm	Pieces	Weight/g
0261001506000	261-150	150	6	17 x 11	5	215
0261001756000	261-175	175	7	17 x 11	5	250
0261002006000	261-200	200	8	20 x 12	5	380
0261002506000	261-250	250	9	23 x 13	5	530

262-...

FLAT CHISEL, OCTAGONAL

- for metal work
- completely hardened and tempered
- striking head inductive tempered
- working edge sharpened and oiled
- shaft black coated
- ELORA-Chrome-Vanadium 59CrV4 / 1.2242



Code	Number	l/mm	Width of Edge mm	Profile mm	Pieces	Weight/g
0262001006000	262-100	100	10	8	5	56
0262001256000	262-125	125	12	10	5	68
0262001506000	262-150	150	16	12	5	118
0262001756000	262-175	175	20	14	5	210
0262002006000	262-200	200	22	16	5	310
0262002506000	262-250	250	26	18	5	490
0262003006000	262-300	300	26	18	5	595

263-...

CROSS-CUT CHISEL, OCTAGONAL

- for metal work
- completely hardened and tempered
- striking head inductive tempered
- working edge sharpened and oiled
- shaft black coated
- ELORA-Chrome-Vanadium 59CrV4 / 1.2242



Code	Number	l/mm ┌──┐	Width of Edge mm	Profile mm	Pieces ☞	Weight/g ⚖
0263001256000	263-125	125	5	8	5	62
0263001506000	263-150	150	6	12	5	108
0263001756000	263-175	175	8	14	5	180
0263002006000	263-200	200	9	16	5	310
0263002506000	263-250	250	10	18	5	445

362-...

BRICKLAYER'S CHISEL, FLAT OVAL

- for stone work
- completely hardened and tempered
- striking head inductive tempered
- working edge sharpened and oiled
- shaft black coated
- ELORA-Chrome-Vanadium 59CrV4 / 1.2242
- according to DIN 7254 Form A



Code	Number	l/mm ┌──┐	Width of Edge mm	Profile mm	Pieces ☞	Weight/g ⚖
0362002006000	362-200	200	26	20 x 12	5	300
0362002506000	362-250	250	26	20 x 12	5	410
0362003006000	362-300	300	29	23 x 13	5	610
0362003506000	362-350	350	29	23 x 13	5	690
0362004006000	362-400	400	29	23 x 13	5	820

364-...

POINT CHISEL, OCTAGONAL

- for stone work
- completely hardened and tempered
- striking head inductive tempered
- working edge sharpened and oiled
- shaft black coated
- ELORA-Chrome-Vanadium 59CrV4 / 1.2242
- according to DIN 7256



Code	Number	l/mm ┌──┐	Width of Edge mm	Profile mm	Pieces ☞	Weight/g ⚖
0364002506000	364-250	250	5	16	5	350
0364003006000	364-300	300	5	18	5	545
0364003506000	364-350	350	5	18	5	670
0364004006000	364-400	400	5	20	5	950

365-...

ELECTRICIAN'S CHISEL, OCTAGONAL

- for stone work
- completely hardened and tempered
- striking head inductive tempered
- working edge sharpened and oiled
- shaft black coated
- ELORA-Chrome-Vanadium 59CrV4 / 1.2242



Code	Number	l/mm ┌──┐	Width of Edge mm	Profile mm	Pieces ☞	Weight/g ⚖
0365020086010	365-200x8x10	200	10	8 x 8	5	115
0365025086010	365-250x8x10	250	10	8 x 8	5	135
0365030106012	365-300x10x12	300	12	10 x 10	5	310

283HS

HAND GUARD

- hand protection against impacts
- no rolling away due to octagonal shape
- suitable for all ELORA chisels, except ELORA-No. 361
- flat oval 20 x 12, 23 x 13, 26 x 13 mm
- octagonal 16, 18, 20 mm
- made of impact resistant special rubber



Code	Number	l/mm	Pieces	Weight/g
0283000000000	283HS	130	6	125

361

SLIT OR CAR BODY CHISEL, EXTRA FLAT

- for car body work
- completely hardened and tempered
- striking head inductive tempered
- working edge sharpened and oiled
- shaft black coated
- ELORA-Chrome-Vanadium 59CrV4 / 1.2242



Code	Number	l/mm	Width of Edge mm	Profile mm	Pieces	Weight/g
0361000000000	361	240	26	26 x 7	5	280

361HS

HAND GUARD FOR SLIT OR CAR BODY CHISEL

- hand protection against impacts
- no rolling away due to octagonal shape
- only for ELORA-No. 361
- made of impact resistant special rubber



Code	Number	l/mm	Stück	Gewicht/g
0361000007000	361HS	130	6	94

260-S5

CHISEL SET

- 5 pcs.
- in black plastic rolling pouch
- completely hardened and tempered
- striking heads inductive tempered
- working edges ground and oiled
- shafts black lacquered
- ELORA-Chrome-Vanadium 59CrV / 1.2242
- according to DIN 6453



Code	Number	Contents	Pieces	Weight/g
0260500056000	260-S5	1 piece each: 260-125 Flat Chisel, flat oval 260-150 Flat Chisel, flat oval 260-175 Flat Chisel, flat oval 260-200 Flat Chisel, flat oval 260-250 Flat Chisel, flat oval	1	1579

265-...

CENTRE PUNCH

- completely hardened and tempered
- striking head inductive tempered
- working edge sharpened and oiled
- shaft black coated
- ELORA-Chrome-Molybdenum-Vanadium 45CrMoV7 / 1.2328
- according to DIN 7250

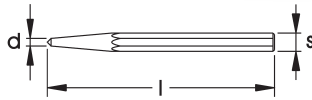

Code	Number	l/mm	d Ø mm	s Ø mm	Pieces	Weight/g
0265001006000	265-10	120	4	10	10	65
0265001206000	265-12	120	5	12	10	90
0265001216000	265-12L	150	5	12	10	120

230

AUTOMATIC PUNCH

- automatic impact execution due to spring mechanism (one hand operation)
- impact can be adjusted
- with hand protection
- nickel plated



Code	Number	l/mm	Pieces	Weight/g
0230000000000	230	145	3	105

264-...

DRIFT PUNCH

- completely hardened and tempered
- striking head inductive tempered
- working edge sharpened and oiled
- shaft black coated
- ELORA-Chrome-Molybdenum-Vanadium 45CrMoV7 / 1.2328
- according to DIN 6458

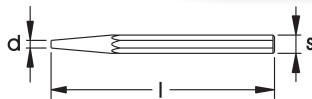

Code	Number	l/mm	d Ø mm	s Ø mm	Pieces	Weight/g
0264012106020	264-120x10x2	120	2,0	10	10	58
0264012106030	264-120x10x3	120	3,0	10	10	62
0264012106040	264-120x10x4	120	4,0	10	10	64
0264012106050	264-120x10x5	120	5,0	10	10	66
0264012106060	264-120x10x6	120	6,0	10	10	66
0264012126020	264-120x12x2	120	2,0	12	10	86
0264012126030	264-120x12x3	120	3,0	12	10	88
0264012126040	264-120x12x4	120	4,0	12	10	90
0264012126050	264-120x12x5	120	5,0	12	10	94
0264012126060	264-120x12x6	120	6,0	12	10	96
0264012126070	264-120x12x7	120	7,0	12	10	96
0264012126080	264-120x12x8	120	8,0	12	10	98
0264012126100	264-120x12x10	120	10,0	12	10	104

You will find mounting drift punches on page no. 386



You will find mounting check plugs on page no. 386



271-...

PARALLEL PIN PUNCH

- completely hardened and tempered
- striking head inductive tempered
- working edge sharpened and oiled
- shaft black coated
- ELORA-Chrome-Vanadium 59CrV4 / 1.2242
- according to DIN 6450



Code	Number	l/mm	l1 mm	d Ø mm	s Ø mm	Pieces	Weight/g
0271000206000	271-2	150	30	2,0	10	10	70
0271000306000	271-3	150	40	3,0	10	10	66
0271000406000	271-4	150	50	4,0	10	10	66
0271000416000	271-4L	175	80	4,0	10	10	62
0271000506000	271-5	150	50	5,0	10	10	66
0271000606000	271-6	150	50	6,0	10	10	70
0271000616000	271-6L	175	80	6,0	10	10	70
0271000706000	271-7	150	50	7,0	12	10	102
0271000806000	271-8	150	50	8,0	12	10	108
0271000906000	271-9	150	50	9,0	12	10	112
0271001006000	271-10	150	50	10,0	12	10	100

270-...

PIN PUNCH WITH GUIDE SLEEVE

- with movable guide sleeve
- ELORA-No. 270-59 with fix guide sleeve
- fine ground and polished
- shaft knurled
- driving point made of 115CrV3 / 1.2210, 55-59 HRC

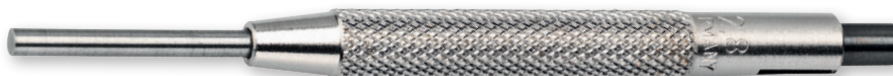

Code	Number	l/mm	Pieces	Weight/g
0270000906000	270-09	80	10	15
0270001406000	270-14	85	10	21
0270001806000	270-18	88	10	25
0270002406000	270-24	92	10	30
0270002806000	270-28	96	10	30
0270003406000	270-34	96	10	35
0270003906000	270-39	100	10	40
0270005906000	270-59	100	10	45



270-S8

PIN PUNCH SET

- 8 pcs.
- in black metal box
- with movable guide sleeve
- ELORA-No. 250-59 with fix guide sleeve
- fine ground and polished
- shaft knurled
- driving point made of 115CrV3 / 1.2210, 55-59 HRC

Code	Number	Contents	Pieces	Weight/g
0270500081000	270-S8	1 pcs. each: Pin Punch with guide sleeve 270-09, 14, 18, 24, 28, 34, 39, 59	10	383

264K / 264KS

DRIFT PUNCH SET

- 6 pcs.
- ELORA-No. 264K in metal box
- ELORA-No. 264KS in plastic holder
- completely hardened and tempered
- striking heads inductive tempered
- working edge sharpened and oiled
- shaft black coated
- ELORA-Chrome-Molybdenum-Vanadium 45CrMoV7 / 1.2328
- according to DIN 6458



Code	Number	Contents	Pieces	Weight/g
0264500606000	264K	1 piece each: 264-120 x 10 x 2 mm, Drift Punch 264-120 x 10 x 3 mm, Drift Punch 264-120 x 10 x 4 mm, Drift Punch 264-120 x 10 x 5 mm, Drift Punch 264-120 x 10 x 6 mm, Drift Punch 265-120 x 10 mm, Centre Punch	1	752
0264500607000	264KS	1 piece each: 264-120 x 10 x 2 mm, Drift Punch 264-120 x 10 x 3 mm, Drift Punch 264-120 x 10 x 4 mm, Drift Punch 264-120 x 10 x 5 mm, Drift Punch 264-120 x 10 x 6 mm, Drift Punch 265-120 x 10 mm, Centre Punch	1	518

266K / 266KS / 266S

CHISEL AND PUNCH SET

- 6 pcs.
- ELORA-No. 266K in metal box
- ELORA-No. 266KS in plastic holder
- ELORA-No. 266S in wooden holder
- completely hardened and striking heads inductive tempered
- working edge sharpened and oiled
- shaft black coated



Code	Number	Contents	Pieces	Weight/g
0266500626000	266K	1 piece each: 262-125 Flat Chisel, octagonal 262-150 Flat Chisel, octagonal 263-125 Cross-Cut Chisel, octagonal 264-120 x 10 x 4 mm, Drift Punch 264-120 x 12 x 4 mm, Drift Punch 265-120 x 10 mm, Centre Punch	1	818
0266500627000	266KS	1 piece each: 262-125 Flat Chisel, octagonal 262-150 Flat Chisel, octagonal 263-125 Cross-Cut Chisel, octagonal 264-120 x 10 x 4 mm, Drift Punch 264-120 x 12 x 4 mm, Drift Punch 265-120 x 10 mm, Centre Punch	1	595
0266500606000	266S	1 piece each: 262-125 Flat Chisel, octagonal 262-150 Flat Chisel, octagonal 263-125 Cross-Cut Chisel, octagonal 264-120 x 10 x 4 mm, Drift Punch 264-120 x 12 x 4 mm, Drift Punch 265-120 x 10 mm, Centre Punch	1	650

271K / 271KS / 271S

PARALLEL PIN PUNCH SET

- 6 pcs.
- ELORA-No. 271K in metal box
- ELORA-No. 271KS in plastic holder
- ELORA-No. 271S in wooden holder
- completely inductive hardened and tempered
- striking heads inductive tempered
- working edge sharpened and oiled
- shaft black coated
- ELORA-Chrome-Vanadium 59CrV4 / 1.2242
- according to DIN 6450



Code	Number	Contents	Pieces	Weight/g
0271500616000	271K	1 piece each Parallel Pin Punch: 271-150 x 2 mm 271-150 x 3 mm 271-150 x 4 mm 271-150 x 5 mm 271-150 x 6 mm 271-150 x 8 mm	1	764
0271500617000	271KS	1 piece each Parallel Pin Punch: 271-150 x 2 mm 271-150 x 3 mm 271-150 x 4 mm 271-150 x 5 mm 271-150 x 6 mm 271-150 x 8 mm	1	530
0271500606000	271S	1 piece each Parallel Pin Punch: 271-150 x 2 mm 271-150 x 3 mm 271-150 x 4 mm 271-150 x 5 mm 271-150 x 6 mm 271-150 x 8 mm	1	583

267-H...

PLASTIC HOLDER FOR IMPACT TOOLS

- for flat oval, octagonal chisels, center punches, drift and pin punches



Code	Number	Shaft size mm	Pieces	Weight/g
0267000017000	267-1H	10, octagonal	10	12
0267000027000	267-2H	12, octagonal	10	12
0267000037000	267-3H	16, octagonal	10	12
0267000047000	267-4H	18, octagonal	10	12
0267000057000	267-5H	20, octagonal	10	12
0267000067000	267-6H	14x9, flat oval	10	12
0267000077000	267-7H	17x11, flat oval	10	12
0267000087000	267-8H	20x12, flat oval	10	12
0267000097000	267-9H	23x13, flat oval	10	12
0267000107000	267-10H	26x13, flat oval	10	12
0267000117000	267-11H	26x7, flat oval	10	12

285-...

WAD PUNCH

- for punching of carton, leather, rubber, sealing material and other soft material
- forged, cutting edge hardened and ground
- shaft red coated
- lightly conical inside for easy removal of the cuttings
- high grade steel
- according to DIN 7200, Form A



Code	Number	Ø	l/mm	Pieces	Weight/g	Code	Number	Ø	l/mm	Pieces	Weight/g
028500026000	285-2	2	105	12	40	0285000376000	285-37	37	205	1	750
0285000036000	285-3	3	105	12	40	0285000386000	285-38	38	205	1	780
0285000046000	285-4	4	105	12	40	0285000396000	285-39	39	210	1	800
0285000056000	285-5	5	110	12	55	0285000406000	285-40	40	210	1	810
0285000066000	285-6	6	110	12	60	0285000416000	285-41	41	210	1	820
0285000076000	285-7	7	120	12	80	0285000426000	285-42	42	220	1	980
0285000086000	285-8	8	120	12	85	0285000436000	285-43	43	220	1	980
0285000096000	285-9	9	120	12	90	0285000446000	285-44	44	220	1	980
0285000106000	285-10	10	130	12	120	0285000456000	285-45	45	220	1	1000
0285000116000	285-11	11	130	12	120	0285000466000	285-46	46	220	1	1100
0285000126000	285-12	12	130	12	120	0285000476000	285-47	47	230	1	1160
0285000136000	285-13	13	140	6	155	0285000486000	285-48	48	230	1	1180
0285000146000	285-14	14	140	6	155	0285000496000	285-49	49	230	1	1190
0285000156000	285-15	15	140	6	160	0285000506000	285-50	50	230	1	1200
0285000166000	285-16	16	140	6	170	0285000516000	285-51	51	230	1	1200
0285000176000	285-17	17	145	6	205	0285000526000	285-52	52	245	1	1850
0285000186000	285-18	18	145	6	210	0285000536000	285-53	53	245	1	1850
0285000196000	285-19	19	145	6	210	0285000546000	285-54	54	245	1	1850
0285000206000	285-20	20	160	6	290	0285000556000	285-55	55	245	1	1850
0285000216000	285-21	21	160	6	290	0285000566000	285-56	56	260	1	1850
0285000226000	285-22	22	160	6	300	0285000576000	285-57	57	260	1	1850
0285000236000	285-23	23	165	3	325	0285000586000	285-58	58	260	1	1850
0285000246000	285-24	24	165	3	340	0285000596000	285-59	59	260	1	1850
0285000256000	285-25	25	170	3	355	0285000606000	285-60	60	260	1	1850
0285000266000	285-26	26	170	3	360	0285000616000	285-61	61	260	1	1850
0285000276000	285-27	27	175	3	450	0285000626000	285-62	62	260	1	1850
0285000286000	285-28	28	175	3	460	0285000636000	285-63	63	260	1	1850
0285000296000	285-29	29	175	3	460	0285000646000	285-64	64	260	1	1850
0285000306000	285-30	30	190	3	560	0285000656000	285-65	65	260	1	3650
0285000316000	285-31	31	190	3	560	0285000666000	285-66	66	300	1	3650
0285000326000	285-32	32	190	3	560	0285000676000	285-67	67	300	1	3650
0285000336000	285-33	33	195	1	640	0285000686000	285-68	68	300	1	3650
0285000346000	285-34	34	195	1	650	0285000696000	285-69	69	300	1	3650
0285000356000	285-35	35	195	1	660	0285000706000	285-70	70	300	1	3650
0285000366000	285-36	36	195	1	660						

285 S8/285 S10

WAD PUNCH SET

- 8 and 10 pcs.
- in black plastic wallet
- for punching of carton, leather, rubber, sealing material and other soft material
- forged, cutting edge hardened and ground
- shaft red coated
- lightly conical inside for easy removal of the cuttings
- high grade steel
- according to DIN 7200, Form A



Code	Number	Contents	Pieces	Weight/g
0285500806000	285 S8	285- 3, 6, 8, 10, 12, 16, 20, 25 mm	1	1489
0285501006000	285 S10	285- 3, 5, 7, 8, 10, 13, 16, 19, 22, 25 mm	1	1866

286-...

BELT PUNCH

- for punching of carton, leather, rubber, sealing material and other soft material
- forged, cutting edge hardened and ground
- shaft red coated
- high grade steel
- according to DIN 7200, Form B



Code	Number	Ø	l/mm	Pieces	Weight/g	Code	Number	Ø	l/mm	Pieces	Weight/g
0286000016000	286-1	1	105	12	20	0286000146000	286-14	14	135	6	195
0286000026000	286-2	2	105	12	20	0286000156000	286-15	15	135	6	200
0286000036000	286-3	3	105	12	25	0286000166000	286-16	16	140	6	260
0286000046000	286-4	4	110	12	35	0286000176000	286-17	17	140	6	270
0286000056000	286-5	5	115	12	40	0286000186000	286-18	18	150	6	320
0286000066000	286-6	6	115	12	45	0286000196000	286-19	19	150	6	365
0286000076000	286-7	7	120	12	60	0286000206000	286-20	20	155	6	410
0286000086000	286-8	8	120	12	75	0286000216000	286-21	21	155	6	440
0286000096000	286-9	9	125	12	100	0286000226000	286-22	22	155	6	490
0286000106000	286-10	10	125	12	115	0286000236000	286-23	23	155	3	490
0286000116000	286-11	11	125	12	150	0286000246000	286-24	24	160	3	550
0286000126000	286-12	12	130	12	180	0286000256000	286-25	25	160	3	550
0286000136000	286-13	13	130	6	185						

400Z-...

NUMBER PUNCH SET

- 9 pcs.
- for driving numbers by impact into steel
- 9 numbers from 0-9
- in stable plastic box
- completely hardened and tempered
- striking heads inductive tempered
- made of hard and tough steel
- according to DIN 1451



Code	Number	Size of letters mm	Shaft size mm	Pieces	Weight/g
0400000020000	400Z-2	2	6×65	1	176
0400000030000	400Z-3	3	6×65	1	174
0400000040000	400Z-4	4	7×65	1	237
0400000050000	400Z-5	5	8×65	1	303
0400000060000	400Z-6	6	9×70	1	436
0400000070000	400Z-7	7	10×75	1	667
0400000080000	400Z-8	8	11×75	1	666
0400000100000	400Z-10	10	12×80	1	828
0400000120000	400Z-12	12	14×80	1	1114
0400000150000	400Z-15	15	16×90	1	1551
0400000200000	400Z-20	20	18×100	1	2640

400B-...

LETTER PUNCH SET

- 27 pcs.
- for driving letters by impact into steel
- 27 capital letters, from A to Z and "&"
- in stable plastic box
- completely hardened and tempered
- striking heads inductive tempered
- made of hard and tough steel
- according to DIN 1451



Code	Number	Size of letters mm	Shaft size mm	Pieces	Weight/g
0400010020000	400B-2	2	6x65	1	491
0400010030000	400B-3	3	6x65	1	503
0400010040000	400B-4	4	7x65	1	663
0400010050000	400B-5	5	8x65	1	888
0400010060000	400B-6	6	9x70	1	1275
0400010070000	400B-7	7	10x75	1	1940
0400010080000	400B-8	8	11x75	1	1933
0400010100000	400B-10	10	12x80	1	2480
0400010120000	400B-12	12	14x80	1	3300
0400010150000	400B-15	15	16x90	1	4560
0400010200000	400B-20	20	18x100	1	7700

745

ROUND AWL

- chrome-plated blade
- nonslip QUATROLIT®-2C-handle
- with suspension hole
- special steel

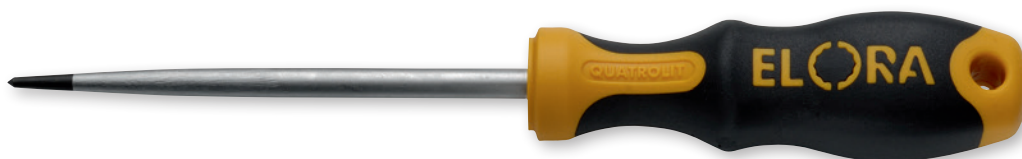

Code	Number	l/mm	Pieces	Weight/g
0745000001000	745	100 x Ø 6	6	75

746

SQUARE AWL

- chrome plated 4 square blade
- nonslip QUATROLIT®-2C-handle
- with suspension hole
- special steel

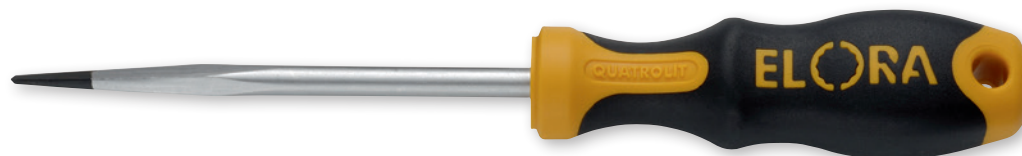

Code	Number	l/mm	Pieces	Weight/g
0746000001000	746	100 x Ø 6	6	75

You will find revolving punch pliers on page no. 344



259-...

MOUNTING DRIFT PUNCH

- completely hardened and tempered
- striking head inductive tempered
- working edge sharpened and oiled
- shaft black coated
- ELORA-Chrome-Vanadium 59CrV4 / 1.2242



Code	Number	l/mm	l1 mm	d1 Ø mm	d2 Ø mm	Pieces	Weight/g
0259000506000	259-5	180	110	5	12	10	110
0259000606000	259-6	200	120	6	13	10	150
0259000806000	259-8	200	130	8	16	5	220
0259000906000	259-9	200	130	9	20	5	340
0259001006000	259-10	230	140	10	22	5	460
0259001106000	259-11	250	155	11	24	3	620
0259001206000	259-12	280	170	12	27	3	870
0259001406000	259-14	315	190	14	30	3	1260
0259001506000	259-15	340	200	15	32	3	1570
0259001606000	259-16	380	220	16	36	3	2230

231-...

MOUNTING CHECK PLUG

- for positioning of drill bores
- shaft tolerance h9
- ELORA-Chrome-Vanadium 59CrV4 / 1.2242

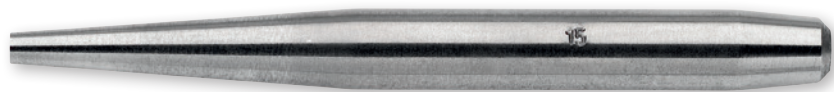

Code	Number	l/mm	Pieces	Weight/g
0231001306000	231-13	120	5	90
0231001506000	231-15	150	5	165
0231001706000	231-17	170	5	240
0231001906000	231-19	170	5	300
0231002106000	231-21	190	5	410
0231002306000	231-23	190	5	485
0231002506000	231-25	200	5	585
0231002806000	231-28	210	5	805
0231003106000	231-31	230	5	1050

359

MOUNTING PUNCH

- completely hardened and tempered
- striking head inductive tempered
- working edge sharpened and oiled
- shaft black coated
- ELORA-Chrome-Molybdenum-Vanadium 45CrMoV7 / 1.2328

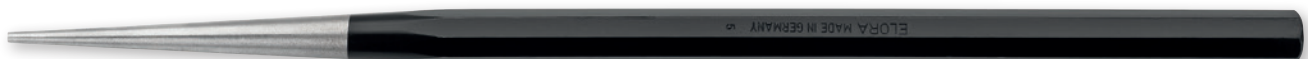

Code	Number	l/mm	Pieces	Weight/g
0359000000000	359	500	3	105

164

PRY BAR

- especially appropriate for difficult to reach areas
- forged pattern
- throughout hardened and tempered to 42–46 HRC
- chrome-plated
- ELORA-Chrome Vanadium 31CrV3 / 1.2208



Code	Number	l/mm	Pieces	Weight/g
0164000000000	164	400	6	475

166

MOUNTING BAR

- for dismantling parts lying on top of each other, for centration of drill bores
- chrome plated 4 square shaft
- ELORA-Chrome-Vanadium 31CrV3 / 1.2208



Code	Number	l/mm	Pieces	Weight/g
0166000000000	166	400	6	500

You will find tyre lever on page no. 447

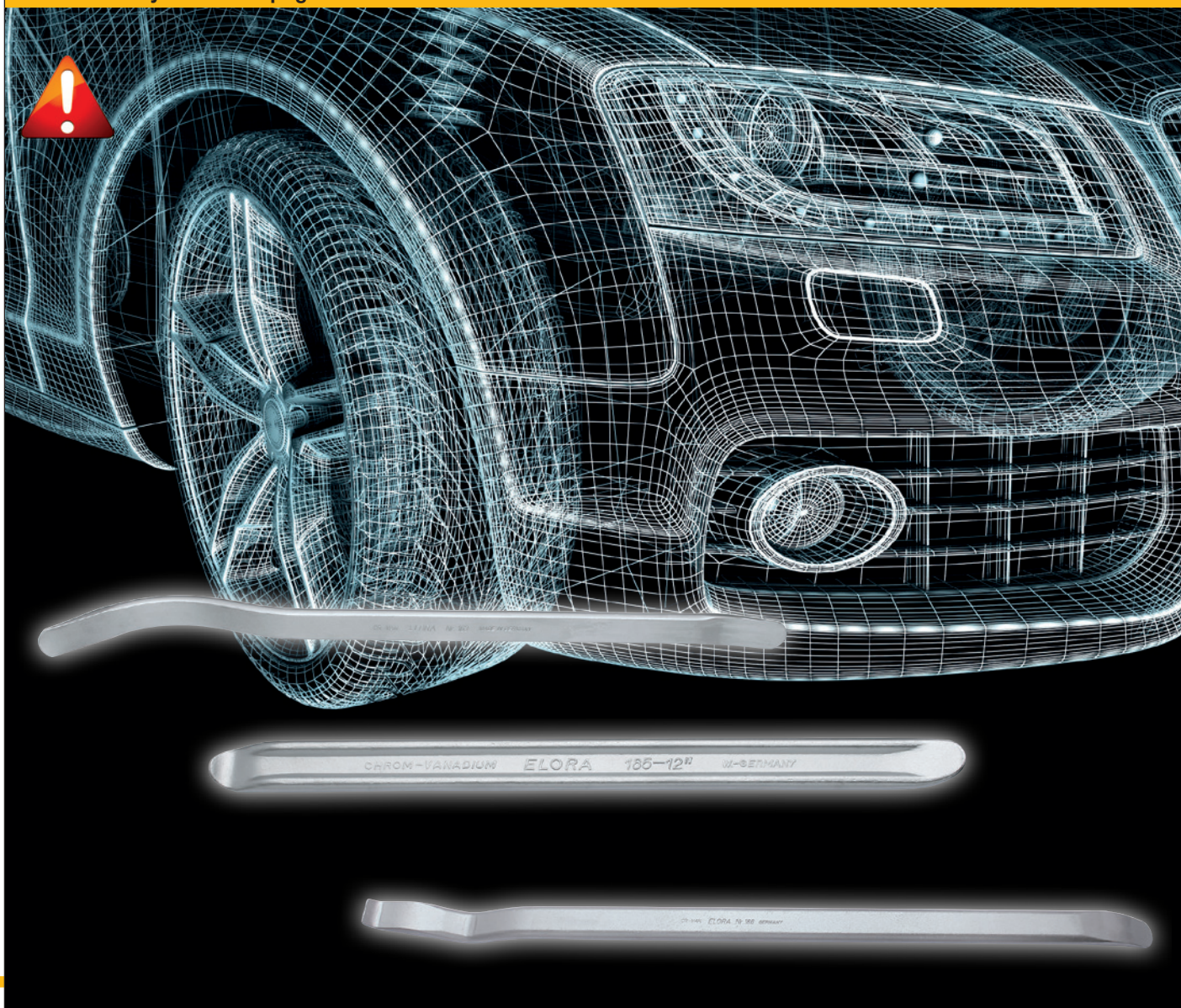

1675/2-...

NAIL LIFTER, HEXAGONAL

- heavy duty pattern
- hardened and tempered
- high grade tool steel
C45 / 1.0503



Code	Number	l/mm ┌──┐	Pieces ☞	Weight/g ⚖
1675004001002	1675/2-400	400	1	900
1675005001002	1675/2-500	500	1	1005
1675006001002	1675/2-600	600	1	1300
1675008001002	1675/2-800	800	1	1700
1675010001002	1675/2-1000	1000	1	2050

1676/1-...

WRECKING BAR

- with straight edge and point
- working end hardened
- high grade tool steel
C45 / 1.0503



Code	Number	l/mm ┌──┐	Pieces ☞	Weight/g ⚖
1676010001001	1676/1-1000	1000	1	5000
1676012501001	1676/1-1250	1250	1	6500
1676015001001	1676/1-1500	1500	1	8000
1676017501001	1676/1-1750	1750	1	9500
1676020001001	1676/1-2000	2000	1	10500

1676/2-...

WRECKING BAR

- with angled edge and straight point
- working end hardened
- high grade tool steel
C45 / 1.0503



Code	Number	l/mm ┌──┐	Pieces ☞	Weight/g ⚖
1676010001002	1676/2-1000	1000	1	5000
1676012501002	1676/2-1250	1250	1	6500
1676015001002	1676/2-1500	1500	1	8000
1676017501002	1676/2-1750	1750	1	9500
1676020001002	1676/2-2000	2000	1	10500

1676/3-...

WRECKING BAR

- with point and claw
- working end hardened
- high grade tool steel C45 / 1.0503



Code	Number	l/mm	Pieces	Weight/g
1676010001003	1676/3-1000	1000	1	5000
1676012501003	1676/3-1250	1250	1	6500
1676015001003	1676/3-1500	1500	1	8000
1676017501003	1676/3-1750	1750	1	9500
1676020001003	1676/3-2000	2000	1	10500

1676/4-...

WRECKING BAR

- heavy duty pattern
- with ball head and edge
- working end hardened
- high grade tool steel C45 / 1.0503



Code	Number	l/mm	Pieces	Weight/g
1676010001004	1676/4-1000	1000	1	5000
1676012501004	1676/4-1250	1250	1	6500
1676015001004	1676/4-1500	1500	1	8000

1676/6-...

WRECKING BAR

- heavy duty pattern
- with curved edge and straight point
- working end hardened
- high grade tool steel C45 / 1.0503



Code	Number	l/mm	Pieces	Weight/g
1676015001006	1676/6-1500	1500	1	10000
1676017501006	1676/6-1750	1750	1	12000
1676020001006	1676/6-2000	2000	1	14000

1495-...

PARALLEL BENCH VICE

- to front opening, wide, hardened anvil surface
- extra large spanning depth
- strong spindle with trapezoid thread
- readjustable guide
- milled spanning jaws
- black coated
- drop forged and hardened
- high grade tool steel C45 / 1.0503



Code	Number	Width of jaws mm	Opening mm	Anvil mm	Pieces	Weight/g
1495001154000	1495-115	115	140	45x63	1	8400
1495001354000	1495-135	135	170	57x75	1	14350
1495001504000	1495-150	150	190	65x80	1	19500
1495002004000	1495-200	175	205	75x93	1	27000

1500A-... / 1500K-...

JAW CAPS FOR BENCH VICES

- fitting to all ELORA Parallel Bench Vices
- with prism
- magnetic strip for safe hold at the jaw
- ELORA-No. 1500A: aluminium-alloy
- ELORA-No. 1500K: plastic



Code	Number	l/mm	Pieces	Weight/g
1500011004000	1500A-100	100	6	72
1500011254000	1500A-125	125	6	90
1500011504000	1500A-150	150	6	110
1500021004000	1500K-100	100	6	34
1500021254000	1500K-125	125	6	40
1500021504000	1500K-150	150	6	48

1495D-...

SWIVEL BASE FOR BENCH VICE

- for use with ELORA-No. 1495
- stepless rotating area 360°
- black coated

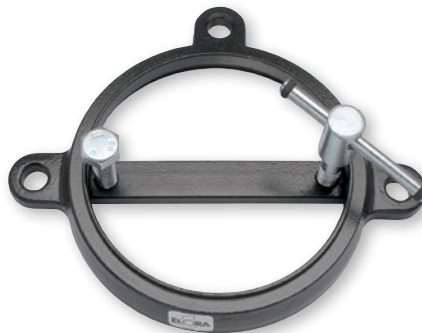

Code	Number	for bench vice ELORA-No.	Bolt Circle mm	Pieces 	Weight/g
1495011154000	1495D-115	1495-115	165	1	580
1495011354000	1495D-135	1495-135	195	1	1080
1495011504000	1495D-150	1495-150	225	1	1400

1495L-135

GAS PRESSURE ELEVATOR FOR BENCH VICE

- for use with ELORA-No. 1495-135
- Gas pressure supported height adjustment for comfortable lifting or sinking of bench vice and work piece
- height range up to 240 mm, rotating area 360°
- black coated



Code	Number	Pieces 	Weight/g
1495021354000	1495L-135	1	9150



PNEUMATIC TOOLS

Pneumatic Tools _____ Page 394

Pneumatic Accessories _____ Page 401



In our Remscheid showroom, just about 50% of our entire product range is presented on 10 walls. With a 100% guarantee that we will have the tool you are looking for!

5003, 5004

PNEUMATIC IMPACT WRENCH MINI, 450 NM

- extremely handy impact wrench with only 160 mm length
- for work at difficult accessible areas
- maximum performance at minimum weight
- with vibration-damped composite housing
- non-slip cold insulated handle
- exhaust air guided through handle
- always full capacity when loosening
- clockwise 3-step torque regulation when tightening
- clockwise/counter clockwise performance regulation protected in rear motor plate
- with high-performance twin-hammer mechanism
- air inlet thread 1/4"
- Operating pressure 6,3 bar
- Tightening torque max. 450 Nm
- max. sound level 95 dB (A) Lp A
- average air consumption 100 l/min
- recommended hose inner-Ø 8 mm
- vibration acceleration 5,9 m/s²
- including brass nipple



10	12,5
3/8"	1/2"

Code	Number		l/mm	Pieces	Weight/g
5003000000000	5003	1/2"	160	1	1575
5004000000000	5004	3/8"	160	1	1563

5000

PNEUMATIC IMPACT WRENCH 1/2", 1350 NM

- extremely powerful and ultra light
- max. torque 1350 Nm at just 2 kg weight
- with vibration-damped composite housing
- non-slip cold insulated handle
- exhaust air guided through handle
- always full capacity when loosening
- clockwise- 3-step torque regulation when tightening
- clockwise/counter clockwise performance regulation protected in rear motor plate
- with high-performance twin-hammer mechanism
- air inlet thread 1/4"
- operating pressure 6,3 bar
- Tightening torque max. 1350 Nm
- Maximum loosening 1850 Nm
- max. sound level 95 dB (A) Lp A
- average air consumption 170 l/min
- recommended hose inner-Ø 8 mm
- vibration acceleration 7,9 m/s²
- including brass nipple



12,5
1/2"

Code	Number		l/mm	Pieces	Weight/g
5000000000000	5000	1/2"	200	1	2280

5001

PNEUMATIC IMPACT WRENCH 3/4", 1900 NM

- extremely powerful and ultra light
- max. torque 1900 Nm at just 3,4 kg weight
- with vibration-damped composite housing
- non-slip cold insulated handle
- exhaust air guided through handle
- always full capacity when loosening
- clockwise- 3-step torque regulation when tightening
- clockwise/counter clockwise performance regulation protected in rear motor plate
- with high-performance twin-hammer mechanism
- air inlet thread 3/8"
- operating pressure 6,3 bar
- Tightening torque max. 1900 Nm
- Maximum loosening 2730 Nm
- max. sound level 95 dB (A) Lp A
- average air consumption 280 l/min
- recommended hose inner-Ø 13 mm
- vibration acceleration 12,3 m/s²
- including brass nipple

20

3/4"



Code	Number		l/mm ┆┆┆	Pieces 	Weight/g
5001000000000	5001	3/4"	240	1	4180

5002

PNEUMATIC IMPACT WRENCH 1" WITH LONG SPINDLE, 2450 NM

- extremely powerful with optimal working weight
- max. torque 2450 Nm at just 7,2 kg weight
- with vibration-damped composite housing
- non-slip cold insulated handle
- swivel air inlet thread and exhaust air guided through handle
- always full capacity when loosening
- clockwise- 3-step torque regulation when tightening
- clockwise/counter clockwise performance regulation protected in rear motor plate
- with super high-performance twin-hammer mechanism
- air inlet thread 1/2"
- operating pressure 6,3 bar
- Tightening torque max. 2450 Nm
- Maximum loosening 3500 Nm
- max. sound level 95 dB (A) Lp A
- average air consumption 370 l/min
- recommended hose inner-Ø 13 mm
- vibration acceleration 52,2 m/s²
- including brass nipple

25

1"



Code	Number		l/mm ┆┆┆	Pieces 	Weight/g 	Gewicht/g
5002000000000	5002	1"	185	500	1	9720

10

5011

PNEUMATIC RATCHET WRENCH 1/4" MINI, 35 NM

- for effortless working at difficult accessible areas
- very light composite housing
- handy design
- clockwise/counter-clockwise convertible at ratchet head
- non-slip cold insulated handle
- exhaust air guided through handle
- little vibration only
- air inlet thread 1/4"
- operating pressure 6,3 bar
- Tightening torque max. 35 Nm
- free-running speed 220 rpm
- max. sound level 72 dB (A) Lp A
- average air consumption 100 l/min
- recommended hose inner-Ø 8 mm
- including brass nipple

6,3

1/4"



Code	Number		l/mm ┆┆┆	Pieces 	Weight/g
5011000000000	5011	1/4"	175	1	680

5010, 5012

PNEUMATIC RATCHET WRENCH 90 NM

- extremely handy ratchet wrench with only 160 mm length
- for effortless working at difficult accessible areas
- maximum performance at minimum weight
- very light composite housing
- handy design
- clockwise/counter-clockwise convertible at ratchet head
- exhaust air guided through handle
- non-slip cold insulated handle
- little vibration only
- air inlet thread 1/4"
- operating pressure 6,3 bar
- Tightening torque max. 90 Nm
- free-running speed 170 rpm
- average air consumption 170 l/min
- max. sound level 93 dB (A) Lp A
- recommended hose inner-Ø 8 mm
- including brass nipple

10

12,5

3/8"

1/2"



5010



5012

Code	Number		l/mm ┆┆┆	Pieces 	Weight/g
5010000000000	5010	1/2"	255	1	1409
5012000000000	5012	3/8"	255	1	1400

5005, 5006

PNEUMATIC DRILL, REVERSIBLE

- robust housing
- handy design
- direction of rotation reversible
- ELORA-No. 5005: drill chuck, clamping capacity up to \varnothing 13 mm
- ELORA-No. 5006: keyless drill-chuck, clamping capacity up to \varnothing 10 mm
- Non-slip cold insulated handle
- exhaust air guided through handle
- little vibration
- air inlet thread 1/4"
- operating pressure 6,3 bar
- ELORA-No. 5005:
max. free-running speed 750 rpm
- ELORA-No. 5006:
max. free running speed 1800 rpm
- max. sound level 87 dB (A) Lp A
- average air consumption 240 l/min
- recommended hose inner- \varnothing 8 mm
- including brass nipple



Code	Number	l/mm	Pieces	Weight/g
5005000000000	5005	205	1	1756
5006000000000	5006	205	1	1422

5014

GRINDER STRAIGHT \varnothing 6 MM

- for grinding, polishing and deburring
- robust and light housing
- ergonomical designed for easy one-handed operation
- low vibration
- Speed infinitely adjustable with safety trigger
- non-slip, cold- insulated handle
- Collet \varnothing 6 mm
- Air-inlet thread 1/4"
- Operating pressure 6,3 bar
- max. free-running speed 25000 rpm.
- max. sound level 86 dB(A) Lp A
- Average air consumption 270 l/min.
- recommended hose inner- \varnothing 8 mm
- including brass nipple



Code	Number	l/mm	Pieces	Weight/g
5014000000000	5014	145	1	651

5015

ANGLE GRINDER Ø 6 MM

- for grinding, polishing and deburring
- robust and light housing
- ergonomically designed for easy one-handed operation
- low vibration
- Speed infinitely adjustable with safety trigger
- Non-slip cold- insulated handle
- Collet Ø 6 mm
- Air-inlet thread 1/4"
- Operating pressure 6,3 bar
- max. free-running speed 22000 rpm.
- max. sound level 72 dB(A) Lp A
- Average air consumption 270 l/min.
- recommended hose inner-Ø 8 mm
- including brass nipple



Code	Number	l/mm	Pieces	Weight/g
5015000000000	5015	145	1	733

5016

ANGLE GRINDER Ø 125 MM

- robust housing
- lateral grip for left and right use
- release with safety trigger
- with spindle lock for disc change
- for grinding discs with Ø 125 mm and 0,8 - 6 mm thickness (M14 x 1,5)
- Air-inlet thread 1/4"
- Operating pressure 6,3 bar
- max. free-running speed 11000 rpm.
- max. sound level 86 dB(A) Lp A
- Average air consumption 490 l/min.
- recommended hose inner-Ø 8 mm
- including brass nipple



Code	Number	l/mm	Pieces	Weight/g
5016000000000	5016	230	1	2140

5017

ANGLE GRINDER Ø 180 MM

- robust housing
- lateral grip for left and right use
- release with safety trigger
- with spindle lock for disc change
- for grinding discs with Ø 180 mm and 0,8 - 6 mm thickness (M14 x 2)
- Air-inlet thread 3/8"
- Operating pressure 6,3 bar
- max. free-running speed 7000 rpm
- max. sound level 86 dB(A) Lp A
- Average air consumption 500 l/min
- recommended hose inner-Ø 13 mm
- including brass nipple



Code	Number	l/mm	Pieces	Weight/g
5017000000000	5017	300	1	4280

5019

NEEDLE SCALER

- for efficient removal of rust or many other coatings
- only suitable for solid metal parts, no steel sheets
- 2-piece housing for easy maintenance
- non-slip cold insulated handle
- 19 (3 mm) needles
- Air-inlet thread 1/4"
- Operating pressure 6,3 bar
- Number of strokes 3700/min
- max. sound level 108 dB(A) Lp A
- Average air consumption 120 l/min.
- recommended hose inner-Ø 8 mm
- including brass nipple



Code	Number	l/mm	Pieces	Weight/g
5019000000000	5019	335	1	3250

5018

SABRE SAW SET

- for metal and body work
- Suitable for small radii
- robust housing and safety lever
- with non-slip cold-insulated handle
- exhaust air guided through handle
- adjustable bow-wing skid
- with 5 sawblades, mini-oiler and swivel connection to prevent kinking of the hose
- Air-inlet thread 1/4"
- Operating pressure 6,3 bar
- Stroke length 10 mm
- Cutting capacity 1,5 mm
- Number of strokes 9500/min.
- max. sound level 83 dB(A) Lp A
- Average air consumption 170 l/min.
- recommended hose inner-Ø 8 mm
- including brass nipple



Code	Number	l/mm	Pieces	Weight/g
501800000000	5018	300	1	700



5020

TIRE INFLATOR, GAUGED

- gauged, with large manometer
- one-hand-use ensures fast correction of tire pressure
- air inlet thread 1/4"
- measuring range 0 - 10 bar, resp. 0-170 PSI
- manometer Ø 75 mm
- including brass nipple



Code	Number	Filler Hose mm	Pieces	Weight/g
5020000000000	5020	500	1	1012

5021

TIRE INFLATOR, DIGITAL, GAUGED

- gauged, with large manometer
- optimum for tire pressure sensors which require highest precision
- professional tire inflator for the control of tire pressure (inflating and deflating)
- fully electronic with system bound software for highest precision (via RC-Regulation 86/217)
- large LCD-Display
- robust, light plastic housing, shock resistant, oil- and petrol resistant
- single-stage valve lever for fast flating and deflating
- indestructive ceramic sensor for longest lifetime and precision
- CE conformity, overpressure warning (>12 bar) and battery power warning
- including battery (3V Lithium, CR2450)
- air inlet thread 1/4"
- scale graduation 0,01 bar
- measuring range 0-12 bar
- inlet pressure max. 14 bar
- On request also available with PSI unit
- including brass nipple



Code	Number	Filler Hose mm	Pieces	Weight/g
5021000000000	5021	600	1	350

5008, 5009

AIR BLOW GUN

- extremely light and resistant composite housing
- scratchproofed on all sensitive areas
- ideally insulated against cold compressed air
- soundproofed by rubber coated soft-nozzle
- efficient also at low pressure, double power compared with standard nozzles
- non-slip rubber covered lever
- large eyelet for simple storage and availability
- long lifetime due to stainless steel valve springs
- air inlet thread 1/4"
- including brass nipple



Code	Number	Airflow l/min	Acoustic level db(A) Lp A	l/mm	Pieces	Weight/g
5008000000000	5008	329	75,1	65	1	160
5009000000000	5009	352	73,4	156	1	180

5007

POCKET BLOW PEN

- with clip
- air flow infinitely adjustable
- air nozzle 3 mm
- clicks directly on air coupling
- air inlet thread 1/4"
- max. inlet pressure: 12 bar
- max. airflow at 6 bar: 300 l/min



Code	Number	l/mm	Pieces	Weight/g
5007000000000	5007	110	1	21

5024-...

COMPRESSED AIR SIGNAL HOSE

- highly flexible hose in signal-green colour
- signal-colour helps to avoid stumble accidents
- ELORA No. 5024-10 pressed with safety coupling ELORA-No. 5025-9 and steel nipple ELORA-No. 5027-9
- temperature resistant from -40°C up to 65°C
- abrasion-proof and highly flexible
- working pressure max. 20 bar (bursting limit at 68 bar)
- Inner- Ø 8 mm, Outer-Ø 10 mm

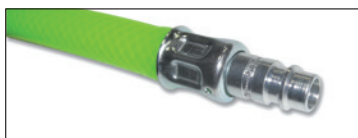

Code	Number	Working length m	Pieces	Weight/g
5024000100000	5024-10	10	1	1600
5024000500000	5024-50	50	1	7340

5022-...

SPIRAL HOSE, POLYURETHAN

- Polyurethan
- Indestructible quality
- with coupling and nipple
- Inner- Ø 8 mm, Outer-Ø 10 mm
- working pressure max. 15 bar (bursting limit at 55 bar)



Code	Number	Working length m	Pieces	Weight/g
5022000400000	5022-4	4	1	500
5022000800000	5022-8	8	1	740

5025-..., 5026-...

SAFETY COUPLING WITH PUSH-BUTTON

- high-quality, robust and durable quick release coupling in safety execution
- one-hand operation
- unlocking by 2 times pressing the push-button
- first push for ventilation off the coupling, but it remains locked
- second push for releasing the coupling, thus preventing the „whiplash effect“
- safety version corresponding to ISO 4414/EN 983
- housing made of aluminium, head and valve of hardened steel, zinc plated
- inner parts made of stainless steel, thread made of brass, nickel plated
- max. pressure 12 bar
- air flow 1800 l/min



Code	Number	Connection	l/mm	Pieces	Weight/g
5025000090000	5025-9	Ø 9 mm hose connection	900	1	139
5025000130000	5025-13	Ø 13 mm hose connection	950	1	140
5026000140000	5026-1/4	1/4" female screw thread	750	1	152
5026000380000	5026-3/8	3/8" female screw thread	750	1	140
5026000120000	5026-1/2	1/2" female screw thread	750	1	160
5026000380001	5026-A 3/8	3/8" external screw thread	700	1	149
5026000120001	5026-A 1/2	1/2" external screw thread	750	1	154

5027-..., 5028-...

PLUG NIPPLE, PLUG NOZZLE MADE OF STEEL

- hardened and zinc plated
- recommended for use with safety couplings
- less wear and tear with maximum service life when compared with ordinary brass-nipples/nozzles



Code	Number	Connection	l/mm	Pieces	Weight/g
5027000090000	5027-9	Ø 9 mm hose connection	480	1	40
5027000130000	5027-13	Ø 13 mm hose connection	480	1	40
5028000140000	5028-A 1/4	1/4" external screw thread	300	1	20
5028000380000	5028-A 3/8	3/8" external screw thread	350	1	20
5028000120000	5028-A 1/2	1/2" external screw thread	400	1	20



MEASURING AND CHECKING TOOLS

Calipers and micrometers _____	Page 406
Tape Measures, Rulers, Spirit Levels, Steel and Dial Indicators _____	Page 411
Angle Bars _____	Page 415
Gauges and Scriber Products _____	Page 418



The ELORA team consists of much more than just 11 field players, who are loyal to us far longer than the standard set in professional soccer. But, of course, we are also passionate about success, technology and team spirit.

1510

VERNIER CALIPER

- in case
- for inside, outside and depth measurement
- reading by vernier scale 0,05 mm respectively 1/128"
- jaw length 40 mm respectively 1.57 inch
- with locking screw
- matt chrome plated



Code	Number	Measuring range mm	Measuring range Inch	Pieces	Weight/g
151000000000	1510	150	6	1	223

1511

POCKET VERNIER CALIPER

- in case
- for inside, outside and depth measurement
- reading by vernier scale 0,05 mm respectively 1/128"
- jaw length 40 mm respectively 1.57 inch
- with thumb lock
- matt chrome plated

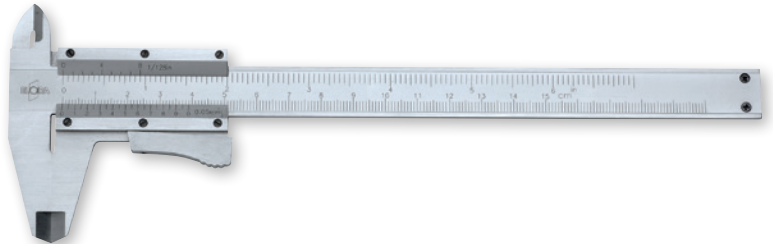

Code	Number	Measuring range mm	Measuring range Inch	Pieces	Weight/g
1511001500000	1511	150	6	1	230

1512

PRECISION VERNIER CALIPER

- in case
- for inside, outside and depth measurement (4 way measurement)
- reading by vernier scale 0,05 mm respectively 1/128"
- jaw length 40 mm respectively 1.57 inch
- with thumb lock
- matt chrome plated reading parts
- thread table on the back
- stainless steel
- DIN 862



Code	Number	Measuring range mm	Measuring range Inch	Pieces	Weight/g
1512000000000	1512	150	6	1	234

1513

PRECISION VERNIER CALIPER

- in case
- for inside, outside and depth measurement (4 way measurement)
- reading by vernier scale 0,05 mm respectively 1/128"
- jaw length 40 mm respectively 1.57 inch
- with thumb lock
- matt chrome plated reading parts
- thread table on the back
- stainless steel
- DIN 862



Code	Number	Measuring range mm	Measuring range Inch	Pieces	Weight/g
1513000000000	1513	150	6	1	220

1520-...

WORKSHOP CALIPER

- for inside, outside measurement
- reading by vernier scale 0,05 mm respectively 1/128"
- with stepped jaws, knife points and locking screw
- matt chrome plated reading parts
- thread table on the back
- stainless steel
- DIN 862



Code	Number	Measuring range mm	Measuring range Inch	Jaws mm	Jaws Inch	Pieces	Weight/g
1520002002000	1520-200	200	8	80	3,2	1	519
1520002502000	1520-250	250	10	80	3,2	1	610
1520003002000	1520-300	300	12	90	3,5	1	687

1522-300

WORKSHOP CALIPER

- in case
- for inside, outside measurement
- reading by vernier scale 0,05 mm respectively 1/128"
- with stepped jaws, knife points, fine adjustment and locking screw
- matt chrome plated reading parts
- thread table on the back
- stainless steel
- DIN 862



Code	Number	Measuring range mm	Measuring range Inch	Jaws mm	Jaws Inch/Inch	Pieces	Weight/g
1522003001000	1522-300	300	12	100	4	1	761

1515-...

PRECISION DIAL CALIPER

- in plastic case
- for inside, outside and depth measurement (4 way measurement)
- 1515-50: reading 0,02 mm
- 1515-100: reading 0,01 mm
- jaw length 40 mm respectively 1,57 inch
- fine adjustment scroll, locking screw
- stainless steel
- DIN 862



Code	Number	Measuring range mm	Measuring range Inch/Inch	Reading mm	Pointer Rotation mm	Pieces	Weight/g
1515000500000	1515-50	150	6	0,02 = 1/50	2	1	388
1515001000000	1515-100	150	6	0,01 = 1/100	1	1	373

1517-...

DIGITAL VERNIER CALIPER

- packed in a plastic bag
- reading 0,01 mm
- pattern with depth measurement and locking screw
- 10 mm LCD-Display
- Stainless steel
- DIN 862

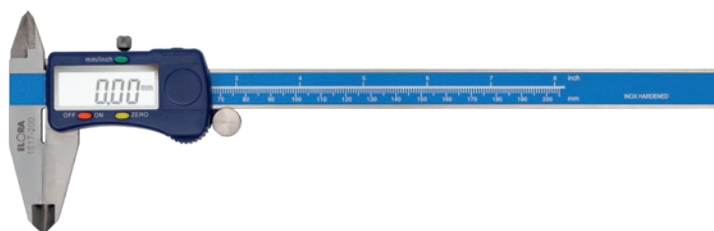

Code	Number	Measuring range mm	Measuring range Inch	Jaws mm	Jaws Inch	Pieces	Weight/g
1517001500000	1517-150	150	6	40	1,6	1	364
1517002000000	1517-200	200	8	50	2,0	1	501
1517003000000	1517-300	300	12	60	2,4	1	801
1517040000000	1517-B	Spare Battery				1	3

1519

BRASS POCKET CALIPER

- in case
- reading by vernier scale 0,1 mm respectively 1/16"
- 20 mm jaw length
- hard brass

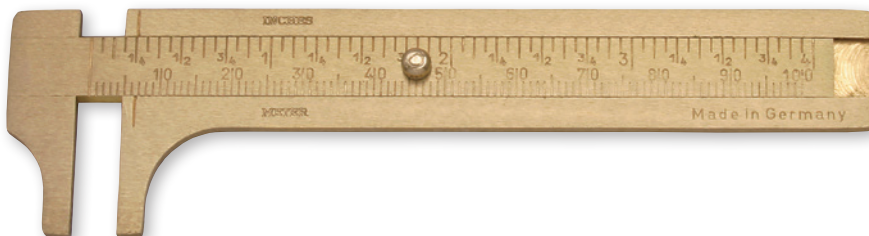

Code	Number	Measuring range mm	Measuring range Inch	Pieces	Weight/g
1519000000000	1519	100	4	1	66

1523

PRECISION VERNIER CALIPER FOR BRAKE DISCS

- carton box packed
- 1/20 mm (reading of 0,05mm) and 1/128" vernier scale
- pattern with trailing vernier and locking screw
- vernier matt chromed
- stainless steel

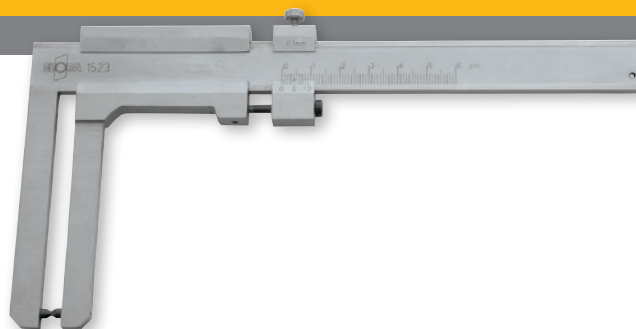

Code	Number	Measuring range mm	Measuring range Inch	Jaws mm	Jaws Inch	Pieces	Weight/g
1523000000000	1523	60	2,4	80	3,2	1	303

1524-...

PRECISION DEPTH VERNIER CALIPER

- in wooden case
- for depth measurement
- reading by vernier scale 0,05 mm
- anti-glare with locking screw
- stainless steel
- DIN 862

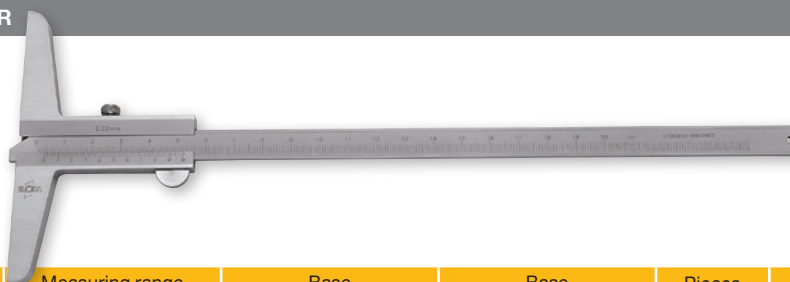

Code	Number	Measuring range mm	Measuring range Inch	Base mm	Base Inch	Pieces	Weight/g
1524002001000	1524-200	200	8	100	4	1	135
1524003001000	1524-300	300	12	100	4	1	280

1530-...

PRECISION OUTSIDE MICROMETER

- in wooden case
- reading 0,01 mm
- pitch 0,5 mm
- matt chrome plated reading parts
- with locking lever, friction coupling and adjustable scale sleeve
- setting standard from ELORA No. 1530-50 upwards
- carbide tipped measuring surfaces
- DIN 863

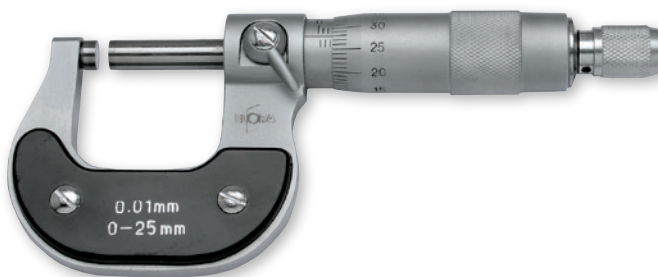

Code	Number	Measuring range mm	Pieces	Weight/g
1530000251000	1530-25	0-25	1	300
1530000501000	1530-50	25-50	1	480
1530000751000	1530-75	50-75	1	640
1530001001000	1530-100	75-100	1	820

1530S4

PRECISION OUTSIDE MICROMETRE SET

- in wooden case
- reading 0,01 mm
- pitch 0,5 mm
- matt chrome plated reading parts
- with locking lever, friction coupling and adjustable scale sleeve
- setting standard from ELORA No. 1530-50 upwards
- carbide tipped measuring surfaces
- DIN 863



Code	Number	Contents	Pieces	Weight/g
1530501001000	1530S4	Precision-Micrometer 1530-25 Measuring range 0-25 mm 1530-50 Measuring range 25-50 mm 1530-75 Measuring range 50-75 mm 1530-100 Measuring range 75-100 mm	1	2140

1532-...

PRECISION INTERNAL MICROMETER

- in plastic storage case
- reading 0,01 mm
- including inspection gauges
- matt chrome plated reading parts
- friction coupling and locking screw



Code	Number	Measuring range mm	Pieces	Weight/g
1532000051000	1532-5	5-30	1	288
1532000251000	1532-25	25-50	1	356
1532000501000	1532-50	50-75	1	346

1535-...

PROTRACTOR

- for measurement of angular degrees 0 – 180°
- with locking screw
- special steel matt chrome plated



Code	Number	Ø of protractor mm	Ø of protractor Inch	Length of rail mm	Length of rail Inch	Pieces	Weight/g
1535000801000	1535-80	80	3,2	120	4,8	1	92
1535001201000	1535-120	120	4,8	150	6	1	158
1535001501000	1535-150	150	6	200	8	1	236
1535002001000	1535-200	200	8	300	12	1	464
1535002501000	1535-250	250	10	500	20	1	560
1535003001000	1535-300	300	12	600	24	1	1319

1537-...

PROTRACTOR

- packed in a plastic bag
- for measurement of angular degrees 10-170°
- pattern with moveable rail and locking screw
- matt chrome plated



Code	Number	Ø of protractor mm	Ø of protractor Inch	Length of rail mm	Length of rail Inch	Pieces	Weight/g
1537001001000	1537-100	100	4	150	6	1	187
1537001501000	1537-150	150	6	300	12	1	427
1537002001000	1537-200	200	8	400	16	1	647

1541-...

UNIVERSAL BEVEL WITH MAGNIFIER

- in plastic case
- 1/12° respectively 5°
- circle graduation 4 x 90°
- hardened rail
- with locking screw
- matt chrome plated reading parts
- stainless steel



Code	Number	l/mm	l/Inch	Pieces	Weight/g
1541002001000	1541-200	200	8	1	628
1541003001000	1541-300	300	12	1	654

1544H

FOLDING RULE

- reading 1 mm
- according to accuracy class III of the EC regulation
- hinges made of epoxy lacquered steel
- with hidden rivet
- beech wood

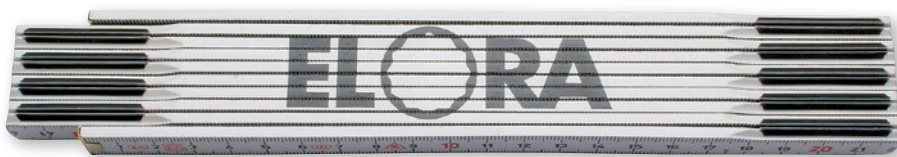

Code	Number	Length m	Pieces	Weight/g
1544000028000	1544H	2	6	125

1546-...

MEASURING TAPE

- according to precision class II
- measuring tape corresponds to EU-directive 2014/32/EU, i.e. it is CE-marked and due to this initially calibrated
- partitioning 1 mm
- automatic strip-intake with return stop
- with one-sided double scale
- gliding end hook, double riveted
- with belt clip
- curved, kink resistant measuring tape
- handy 2 component housing made of high-strength ABS plastic
- measuring tape made of 65Mn spring steel, yellow
- with nylon coat, ensuring abrasion resistance and anticorrosive coating



Code	Number	Length of tape m	Width of tape mm	l/mm	Pieces	Weight/g
1546000030000	1546-3	3	16	60,8	1	116
1546000050000	1546-5	5	19	70,9	1	223
1546000080000	1546-8	8	25	83,0	1	430
1546000100000	1546-10	10	25	92,1	1	492

1546XL-...

MEASURING TAPE

- according to precision class II
- measuring tape corresponds to EU-directive 2014/32/EU, i.e. it is CE-marked and due to this initially calibrated
- with warp resistant, light A-frame
- with tangential tape extraction for protection against deformation of the tape
- ergonomic grip design
- steal measuring tape, white lacquered and sealed with transparent UV-lacquer
- protection against subsurface corrosion by zinc phosphating
- one-sided partitioning mm
- start A (measure starts approx. 10 cm behind the fitting) with plastic ring
- roll-up mechanism running on a steel shaft with high plain bearings effect



Code	Number	Length of tape m	Width of tape mm	l/mm	Pieces	Weight/g
1546000302000	1546XL-30	30	13	320	1	780
1546000502000	1546XL-50	50	13	350	1	1200

1545-...

FLEXIBLE STEEL RULE

- according to accuracy class II of the EC regulation
- graduation in mm
- stainless spring band steel



Code	Number	Measurement mm	Pieces 	Weight/g
1545001501000	1545-150	150 × 13 × 0,5	6	10
1545002001000	1545-200	200 × 13 × 0,5	6	10
1545003001000	1545-300	300 × 13 × 0,5	6	20
1545005001000	1545-500	500 × 20 × 0,5	1	47
1545010001000	1545-1000	1000 × 20 × 0,5	1	84

1547-...

FLEXIBLE STEEL RULE

- according to accuracy class II of the EC regulation
- graduation in mm
- stainless spring band steel



Code	Number	Measurement mm	Pieces 	Weight/g
1547003001000	1547-300	300 × 30 × 1,0	6	60
1547005001000	1547-500	500 × 30 × 1,0	1	130
1547010001000	1547-1000	1000 × 30 × 1,0	1	270

1552-...

ALUMINIUM RULER

- graduation in mm
- pattern with touching edge and anodized surface
- aluminium alloy



Code	Number	Measurement mm	Pieces 	Weight/g
1552003001000	1552-300	300 × 50 × 5	1	190
1552006001000	1552-600	600 × 50 × 5	1	365
1552010001000	1552-1000	1000 × 50 × 5	1	605

1582-...

MARKING GAUGE WITH FLAT SLIDER

- for precise measurement by stop on the work piece
- graduation in mm
- flat pattern with hardened marking edge and locking screw
- matt chrome plated
- factory norm



Code	Number	l/mm 	l/Inch 	Pieces 	Weight/g
1582002001000	1582-200	200	8	1	421
1582002501000	1582-250	250	10	1	467
1582003001000	1582-300	300	12	1	586

1553-...

PRECISION STRAIGHT-EDGE RULER

- in case
- accuracy class 00
- for checking the evenness of surfaces
- through hardened, measuring surfaces lapped
- handle insulated as isolation against hand warm
- high grade tool steel
- DIN 874



Code	Number	Measurement mm	Measurement Inch	Pieces 	Weight/g
1553001001000	1553-100	100	4	1	81
1553001501000	1553-150	150	6	1	150
1553002001000	1553-200	200	8	1	245
1553003001000	1553-300	300	12	1	622
1553005001000	1553-500	500	20	1	1756



1554-...

SPIRIT LEVEL

- accuracy: 0,5 mm/m = 0,029°
- with unbreakable vials made of acrylic glass
- horizontal vials with magnifying lens
- lateral mm graduation
- rectangular aluminium profile (50 x 21 mm), surface plastic coated



Code	Number	l/mm	l/Inch	Pieces	Weight/g
1554004000000	1554-400	400	16	1	353
1554006000000	1554-600	600	24	1	443
1554008000000	1554-800	800	32	1	555
1554010000000	1554-1000	1000	40	1	687

1555

PRECISION DIAL INDICATOR

- in plastic storage case
- clamping shank 8h6 diameter
- adjustable tolerance marks
- housing made of stainless steel



Code	Number	Measuring range mm	Reading mm	Outside Ø mm	Pieces	Weight/g
1555000000000	1555	0-10	0,01	58	1	274

1557

PRECISION DIAL MINI INDICATOR

- in plastic storage case
- clamping shank 8h6
- adjustable tolerance marks
- housing made of stainless steel



Code	Number	Measuring range mm	Reading mm	Outside Ø mm	Pieces	Weight/g
1557000000000	1557	0-5	0,01	40	1	143

1565

UNIVERSAL MAGNETIC DIAL GAUGE STAND

- for holding dial indicators ELORA-No. 1555 and 1557
- on / off switching for activation of the magnetic stand (65 x 50 x 55 mm) with an adhesive force of 600N
- Ø 8 mm dial indicator holding hole
- vertical bar 230 mm, horizontal bar 200 mm
- leverage hard chrome plated with fine adjustment



Code	Number	l/mm	Pieces	Weight/g
1565000000000	1565	280	1	1864

1566GU-...

JOINER'S SQUARE

- short steel side 20 mm
- try square with mitre
- long steel side with 2 scales
- short steel side made of die cast metal

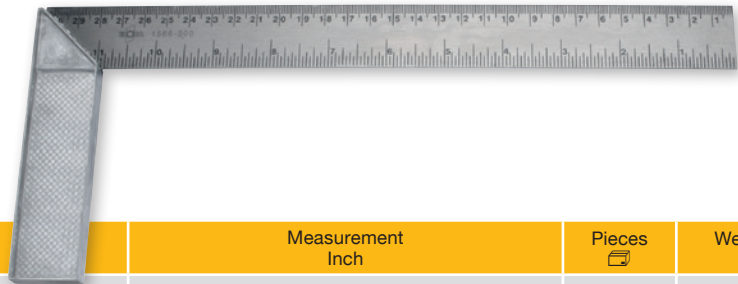

Code	Number	Measurement mm	Measurement Inch	Pieces	Weight/g
1566002501000	1566GU-250	250	10	6	140
1566003001000	1566GU-300	300	12	6	150

1566H-...

JOINER'S SQUARE

- try square with mitre
- long steel side with 2 scales
- short side made of beech wood with brass fittings

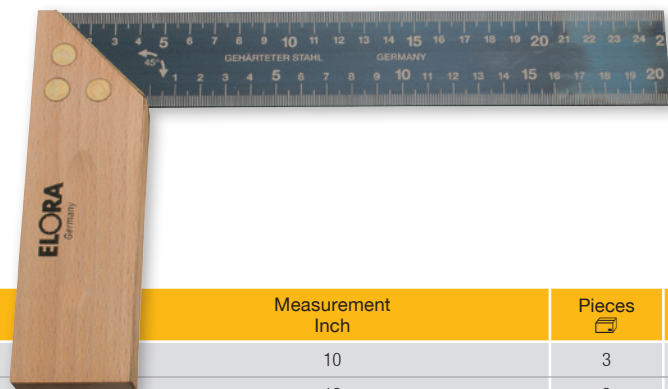

Code	Number	Measurement mm	Measurement Inch	Pieces	Weight/g
1566012501000	1566H-250	250	10	3	170
1566013001000	1566H-300	300	12	3	200
1566014001000	1566H-400	400	16	3	270

1567GU-...

JOINER'S SLIDING BEVEL

- with locking screw
- leg made of die cast metal, tongue made of hardened steel



Code	Number	Measurement mm	Measurement Inch	Pieces	Weight/g
1567002501000	1567GU-250	250	10	6	285
1567003001000	1567GU-300	300	12	6	320

1567H-...

JOINER'S SLIDING BEVEL

- with locking screw
- side made of beech wood with brass fittings
- blue hardened steel blade



Code	Number	Measurement mm	Measurement Inch	Pieces	Weight/g
1567012001000	1567H-200	200	8	6	110
1567012501000	1567H-250	250	10	6	130
1567013001000	1567H-300	300	12	6	150

1569-...

PRECISION STEEL SQUARE

- accuracy class 00
- long side with knife edges on both sides
- measuring surface lapped
- high-tensile steel, through hardened
- DIN 875



Code	Number	Measurement mm	Pieces 	Weight/g
1569000501000	1569-50	50 x 40	1	35
1569000751000	1569-75	75 x 50	1	60
1569001001000	1569-100	100 x 70	1	126
1569001501000	1569-150	150 x 100	1	293

1570-.../1571-...

ENGINEER STEEL SQUARE

- 1570: 90° plain blade without stop
- 1571: 90° blade with stop
- with exposed try square
- zinc coated
- steel



Code	Number	Measurement mm	Pieces 	Weight/g
1570001001000	1570-100	100 x 70	6	70
1570001501000	1570-150	150 x 100	6	150
1570002001000	1570-200	200 x 130	6	250
1570002501000	1570-250	250 x 160	6	350
1570003001000	1570-300	300 x 180	6	400
1570004001000	1570-400	400 x 230	6	575
1570005001000	1570-500	500 x 280	6	770
1570006001000	1570-600	600 x 330	1	1000
1570007501000	1570-750	750 x 380	1	1200
1570010001000	1570-1000	1000 x 500	1	1850
1571001001000	1571-100	100 x 70	4	105
1571001501000	1571-150	150 x 100	4	235
1571002001000	1571-200	200 x 130	4	350
1571002501000	1571-250	250 x 160	4	475
1571003001000	1571-300	300 x 180	2	550
1571004001000	1571-400	400 x 230	2	800
1571005001000	1571-500	500 x 280	2	1100
1571006001000	1571-600	600 x 330	1	1380
1571007501000	1571-750	750 x 380	1	1660
1571010001000	1571-1000	1000 x 500	1	2220

1577-...

PRECISION CENTER SQUARE

- for scribing the centre of round components
- rail with mm graduation
- matt chrome plated
- factory norm

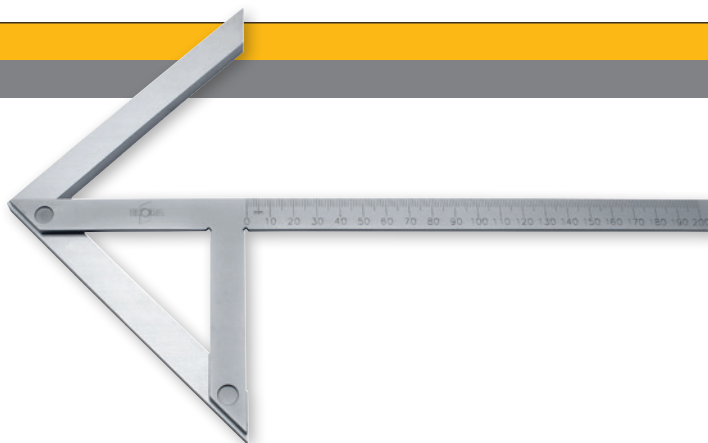

Code	Number	Measurement mm	Cross Section mm	90° Angle mm	Pieces	Weight/g
1577001501000	1577-150	150 x 130	16 x 5	9 x 11	1	477
1577002001000	1577-200	200 x 150	18 x 5	9 x 19	1	581

1578-...

FLANGE STEEL SQUARE

- for alignment off flanges
- zinc coated
- steel
- factory norm



Code	Number	Measurement mm	Flange width mm	Pieces	Weight/g
1578003001000	1578-300	300 x 300	100 x 65	1	912
1578004001000	1578-400	400 x 400	125 x 70	1	1140
1578005001000	1578-500	500 x 500	125 x 70	1	1440
1578006001000	1578-600	600 x 600	125 x 100	1	1600

1579-...

METRE SQUARE 135°

- with stop
- zinc coated
- special steel



Code	Number	Measurement mm	Pieces	Weight/g
1579001501000	1579-150	150 x 100	1	298
1579002001000	1579-200	200 x 130	1	400

188-...M, 188-...Z

FEELER GAUGE

- standard pattern with protection grip
- retractable blades
- blade length 100 mm
- conical blades
- spring band steel



Code	Number	Thickness mm	Pieces	Weight/g	Code	Number	Thickness Inch	Pieces	Weight/g
0188000804000	188-8M	0,05, 0,10, 0,15, 0,20, 0,25, 0,30, 0,40, 0,50	10	35	0188011004000	188-11Z	.0015, .002, .003, .004, .006, .008, .010, .012, .015, .020, .025	10	38
0188000814000	188-81M	0,03, 0,04, 0,05, 0,06, 0,07, 0,08, 0,09, 0,10	10	22	0188013004000	188-13Z	.002, .003, .004, .005, .006, .008, .010, .012, .015, .020, .025, .030, .035	10	52
0188001304000	188-13M	0,05, 0,10, 0,15, 0,20, 0,25, 0,30, 0,40, 0,50, 0,60, 0,70, 0,80, 0,90, 1,00	10	68	0188020004000	188-20Z	.002, .003, .004, .005, .006, .007, .008, .009, .010, .011, .012, .013, .014, .016, .018, .020, .022, .024, .030, .035	10	74
0188002004000	188-20M	0,05, 0,10, 0,15, 0,20, 0,25, 0,30, 0,35, 0,40, 0,45, 0,50, 0,55, 0,60, 0,65, 0,70, 0,75, 0,80, 0,85, 0,90, 0,95, 1,00	10	106	0188022004000	188-22Z	.004, .005, .006, .007, .008, .009, .010, .011, .012, .013, .014, .015, .016, .017, .018, .019, .020, .021, .022, .023, .024, .025	10	85
0188002014000	188-201M	0,05, 0,10, 0,20, 0,30, 0,40, 0,50, 0,60, 0,70, 0,80, 0,90, 1,00, 1,10, 1,20, 1,30, 1,40, 1,50, 1,60, 1,70, 1,80, 1,90, 2,00	10	185	0188026004000	188-26Z	.0015, .002, .0025, .003, .004, .005, .006, .007, .008, .009, .010, .011, .012, .013, .014, .015, .016, .017, .018, .019, .020, .021, .022, .023, .024, .025	10	86
0188002104000	188-21M	0,10, 0,12, 0,14, 0,16, 0,18, 0,20, 0,22, 0,24, 0,26, 0,28, 0,30, 0,32, 0,34, 0,36, 0,38, 0,40, 0,42, 0,44, 0,46, 0,48, 0,50	10	70					
0188002604000	188-26M	0,03, 0,04, 0,05, 0,06, 0,07, 0,08, 0,09, 0,10, 0,15, 0,20, 0,25, 0,30, 0,35, 0,40, 0,45, 0,50, 0,55, 0,60, 0,65, 0,70, 0,75, 0,80, 0,85, 0,90, 0,95, 1,00	10	104					

188MZ-25

FEELER GAUGE

- 25 pcs.
- double marked (mm, AF)
- standard pattern with protection grip
- retractable blades
- blade length 100 mm
- conical blades
- spring band steel



Code	Number	Thickness mm	Thickness Inch	Pieces	Weight/g
0188000004000	188MZ-25	0,04, 0,05, 0,08, 0,10, 0,12, 0,15, 0,18, 0,20, 0,22, 0,25, 0,28, 0,30, 0,33, 0,35, 0,38, 0,40, 0,43, 0,45, 0,50, 0,55, 0,63, 0,75, 0,80, 0,88, 1,00	0,0015, 0,0020, 0,0030, 0,0040, 0,0050, 0,0060, 0,0070, 0,0080, 0,0090, 0,0100, 0,0110, 0,0120, 0,0130, 0,0140, 0,0150, 0,0160, 0,0170, 0,0180, 0,0200, 0,0220, 0,0250, 0,0300, 0,0320, 0,0350, 0,0400	10	86

188R-...

FEELER GAUGE, STAINLESS STEEL

- 188R-13M: 13 pcs.
- 188R-20M: 20 pcs.
- standard pattern with protection grip
- retractable blades
- blade length 100 mm
- conical blades
- stainless steel



Code	Number	Thickness mm	Pieces	Weight/g
0188500134000	188R-13M	0,05, 0,10, 0,15, 0,20, 0,25, 0,30, 0,40, 0,50, 0,60, 0,70, 0,80, 0,90, 1,00	10	60
0188500204000	188R-20M	0,05, 0,10, 0,15, 0,20, 0,25, 0,30, 0,35, 0,40, 0,45, 0,50, 0,55, 0,60, 0,65, 0,70, 0,75, 0,80, 0,85, 0,90, 0,95, 1,00	10	95

194-...

NOZZLE GAUGE

- 194-20M: 20 pcs.
- 194-16M: 16 pcs.
- polished precision pins
- high grade tool steel



Code	Number	Gauge Ø mm	l/mm	Pieces	Weight/g
0194500204000	194-20M	0,45, 0,50, 0,55, 0,60, 0,65, 0,70, 0,75, 0,80, 0,85, 0,90, 0,95, 1,00, 1,05, 1,10, 1,15, 1,20, 1,25, 1,30, 1,40, 1,50 mm	65	12	68
0194600164000	194-16M	1,50, 1,60, 1,70, 1,80, 1,90, 2,00, 2,10, 2,20, 2,30, 2,40, 2,50, 2,60, 2,70, 2,80, 2,90, 3,00 mm	65	12	78

197-...

FEELER GAUGE TAPE

- in plastic box
- length 5 m, width 13 mm
- thickness markings each 10 cm
- spring band steel
- 197-01 and 197-02: stainless steel



Code	Number	Thickness mm	Pieces	Weight/g
0197000014000	197-01	0,01	6	22
0197000024000	197-02	0,02	6	30
0197000034000	197-03	0,03	6	32
0197000044000	197-04	0,04	6	38
0197000054000	197-05	0,05	6	44
0197000064000	197-06	0,06	6	50
0197000074000	197-07	0,07	6	52
0197000084000	197-08	0,08	6	60
0197000104000	197-10	0,10	6	78
0197000154000	197-15	0,15	6	102
0197000204000	197-20	0,20	6	130
0197000254000	197-25	0,25	6	150
0197000304000	197-30	0,30	6	165
0197000404000	197-40	0,40	6	255
0197000504000	197-50	0,50	6	345

8421/8422/8423

RADIUS GAUGE, CONCAVE AND CONVEX

- with locking screw
- special steel

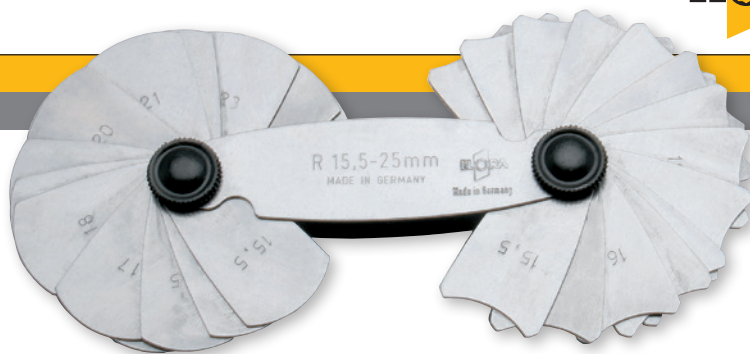

Code	Number	Radius mm	Blade	Pieces	Weight/g
8421000000000	8421	1,0-7	17	6	63
8422000000000	8422	7,5-15	16	6	97,6
8423000000000	8423	15,5-25	15	6	92,7

1580-...

INSIDE CALIPER

- for transferring inside measurements
- polished with riveted hinge
- punched bright steel



Code	Number	l/mm	l/Inch	Pieces	Weight/g
1580002002000	1580-200	200	8	1	114
1580003002000	1580-300	300	12	1	206

1581-...

EXTERNAL CALIPER

- for transferring outside measurements
- polished with riveted hinge
- punched bright steel



Code	Number	l/mm	l/Inch	Pieces	Weight/g
1581002002000	1581-200	200	8	1	142
1581002502000	1581-250	250	10	1	218
1581003002000	1581-300	300	12	1	332
1581005002000	1581-500	500	20	1	968

1584-...

DIVIDER

- drop forged pattern with hardened points
- opening angle 0-180°
- polished with riveted hinge
- special steel



Code	Number	l/mm	l/Inch	Shank cross section approx mm	Pieces	Weight/g
1584001501000	1584-150	150	6	7 x 8	1	143
1584002001000	1584-200	200	8	9 x 10	1	237
1584002501000	1584-250	250	10	9 x 9	1	303
1584003001000	1584-300	300	12	9 x 9	1	380
1584005001000	1584-500	500	20	12 x 12	1	1030

1585-...

BOW DIVIDER

- drop forged pattern with hardened points
- opening angle 0-85°
- standing bow
- polished with riveted hinge
- special steel



Code	Number	l/mm	l/Inch	Pieces	Weight/g
1585001501000	1585-150	150	6	1	179
1585002001000	1585-200	200	8	1	353
1585002501000	1585-250	250	10	1	347
1585003001000	1585-300	300	12	1	445
1585004001000	1585-400	400	16	1	638
1585005001000	1585-500	500	20	1	1021

1586-200

DIVIDER WITH PENCIL HOLDER

- drop forged pattern with hardened points
- opening angle 0-85°
- with standing bow and pencil holder
- polished with riveted hinge
- special steel



Code	Number	l/mm	l/Inch	Pieces	Weight/g
1586002001000	1586-200	200	8	1	265

1587-...

SPRING DIVIDER

- square blade with hardened points
- end-to-end spindle
- special steel

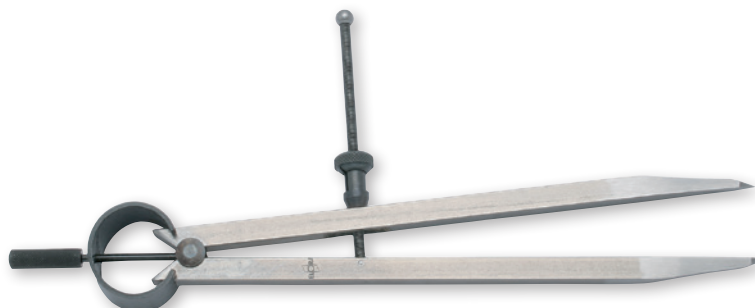

Code	Number	l/mm	l/Inch	Pieces	Weight/g
1587001501000	1587-150	150	6	1	171
1587002001000	1587-200	200	8	1	160
1587002501000	1587-250	250	10	1	267

1590/1590E

ENGINEER'S SCRIBER

- grip gunmetal-finished and knurled
- with interchangeable, screwed steel point
- high grade tool steel



Code	Number	l/mm	l/Inch	Pieces	Weight/g
1590000005100	1590	175	7	12	40
1590400005100	1590E	90	3,5	1	5

1591/1591E

ENGINEER'S SCRIBER

- grip gunmetal-finished and knurled
- with one straight and one angled interchangeable, screwed steel point
- 1591-E80: Spare point straight, 1591-E90: Spare point bent
- high grade tool steel



Code	Number	l/mm	l/Inch	Pieces	Weight/g
1591000005100	1591	250	10	12	50
1591400805100	1591-E80	80	3,2	1	5
1591400905100	1591-E90	80	3,2	1	5

1592

CARBIDE HEXAGON ENGINEER'S SCRIBER

- pattern with hexagonal shaft and deep inserted point
- chrome plated pocket clip
- carbide point



Code	Number	l/mm	l/Inch	Pieces	Weight/g
1592000000000	1592	145	5,8	12	40

1593/1593E

CARBIDE ENGINEER'S SCRIBER

- with interchangeable-, on both sides useable points
- points immersible for protection against damages and risk of injury
- shaft with pocket clip and ribbing surface at the gripping area
- 1593E: Spare point
- carbide point, shaft made of plastic



Code	Number	l/mm	l/Inch	Pieces	Weight/g
1593000000000	1593	150	6	12	35
1593400250000	1593E	25	1	1	5





AUTO- MOTIVE- AND SPECIAL TOOLS

Engine, Oil Service, Exhaust, Clutch _____	Page 426
Brakes, Wheels, Chassis _____	Page 443
Car Bodyworks _____	Page 451
Battery _____	Page 459
Pullers _____	Page 461
Motor Vehicle-Tool Kits _____	Page 470



Working 12 months a year for the ELORA family, from morning to night. Except at Christmas! This is the time to be spent with private family and friends.

230-...

VALVE SPRING COMPRESSOR

- for OHC and DOHC motors
- with a straight and a cranked claw pair
- handle plastic coated
- metal sheet nickel-plated

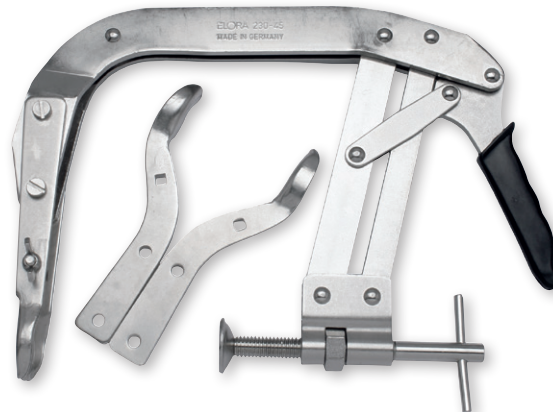

Code	Number	Span Width mm	l/mm	Pieces	Weight/g
0230000453000	230-45	45-225	290	1	1325
0230400453000	230E-45	Spare jaw, straight	-	1	106
0230400753000	230E-75	Spare jaw, cranked	-	1	110

230-115

VALVE SPRING COMPRESSOR

- for OHC and DOHC motors
- with a straight and a cranked claw pair
- metal sheet, nickel-plated



Code	Number	Span Width mm	l/mm	Pieces	Weight/g
0230401153000	230E-115	Spare jaw, straight	-	1	114
0230401503000	230E-150	Spare jaw, cranked	-	1	106

234

VALVE SPRING RETAINER PLIER

- for inserting valve spring retainer
- metal sheet, nickel plated



Code	Number	l/mm	Pieces	Weight/g
0234000000000	234	175	1	111

303-...

VALVE GRINDER TOOL

- for grinding-in the engine valve seats
- rubber suction cup on both ends
- with wooden shaft



Code	Number	Ø mm	l/mm	Pieces	Weight/g
0303000198000	303-19	19x22	200	6	63
0303000228000	303-22	22x32	200	6	63

178-...

STUD EXTRACTOR

- for left and right hand thread
- zinc-plated, spindle gunmetal-finish with 19 mm hexagonal drive
- high grade tool steel C45 / 1.0503



Code	Number	for studs Ø mm	Pieces	Weight/g
0178000151000	178-15	5-15	1	359
0178000201000	178-20	5-20	1	412
0178000221000	178-22	10-19	1	370
0178000281000	178-28	18-28	1	545

232-...

PISTON RING COMPRESSOR

- for pre-loading of the piston rings during insertion of the pistons into the cylinder
- light pattern, continuously adjustable
- wrench included
- high-tensile spring band steel C75 / 1.0605



Code	Number	Span Ø mm	Height mm	Pieces	Weight/g
0232000107000	232-1	57-125	80	1	321
0232000117000	232-1A	57-125	100	1	345
0232000207000	232-2	90-175	80	1	360
0232000217000	232-2A	90-175	100	1	390
0232000307000	232-3	90-175	165	1	634

You will find scrapers
on page no. 480



232S-...

PISTON RING COMPRESSOR

- for pre-loading of the piston rings during insertion of the pistons into the cylinder
- heavy pattern, continuously adjustable
- wrench included
- high-tensile spring band steel C75 / 1.0605

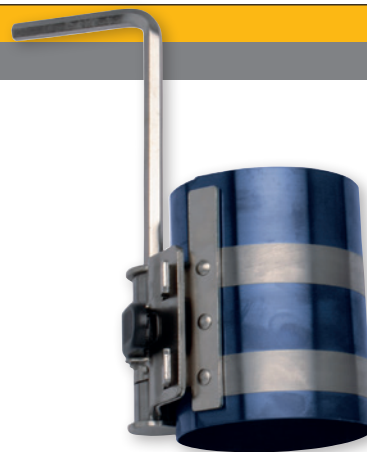

Code	Number	Span Ø mm	Height mm	Pieces 	Weight/g
0232010107000	232S-1	57-125	80	1	311
0232010117000	232S-1A	57-125	100	1	345
0232010207000	232S-2	90-175	80	1	351
0232010217000	232S-2A	90-175	100	1	384
0232010307000	232S-3	90-175	165	1	679

235-...

PISTON RING PLIER

- for inserting and removing piston rings
- nickel-plated, with plastic handles
- high grade tool steel C45 / 1.0503



Code	Number	Span Ø mm	l/mm 	Pieces 	Weight/g
0235000503000	235-50	50-100	200	1	294
0235000803000	235-80	80-120	220	1	335
0235001103000	235-110	90-150	240	1	484

235-60

PISTON RING PLIER

- with prism holder for safe spreading of different piston rings
- nickel plated
- prism holder gunmetal-finish
- high grade tool steel C45 / 1.0503

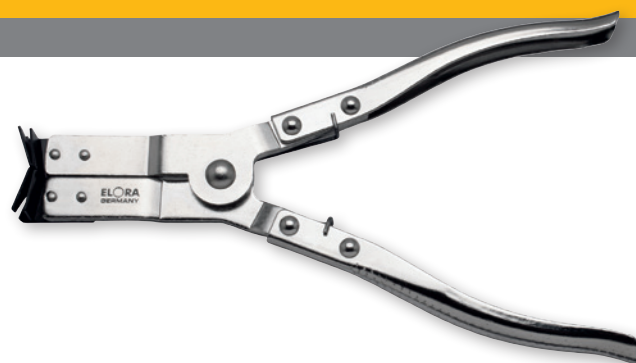

Code	Number	Span Ø mm	l/mm 	Pieces 	Weight/g
0235000603000	235-60	60-160	220	1	246

244-4

HOSE CLAMP PLIER

- for mounting and dismounting of self spanning, spring strip and space-saving clamp
- for clamps Ø 7-60 mm
- due to bowden cable operating mechanism (610 mm) suitable for difficult to reach areas
- nickel-plated, joint gunmetal-finish
- high grade tool steel



Code	Number	l/mm	Pieces	Weight/g
0244000040000	244-4	255	1	675

244-C

CLIC-HOSE CLAMP PLIER

- for CLIC-Hose clamps on fuel feed pipes(e.g. VW, Audi, Peugeot)
- opening and closing of the hose clamps by turning the Plier 180°
- with fix jaws, bent by 90°
- span width 20 mm
- nickel-plated, joint gunmetal-finish
- high grade tool steel



Code	Number	l/mm	Pieces	Weight/g
0244000100000	244-C	175	1	175

You will find pry bars
on page no. 387



You will find mounting bars
on page no.387



244-1

HOSE CLAMP PLIER

- ▶ for simple self spanning wire hose clamps (e.g. washing machines)
- ▶ lockable in 3 positions
- ▶ nickel-plated
- ▶ jaws made of high grade tool steel C45 / 1.0503



Code	Number	l/mm	Pieces	Weight/g
0244000000000	244-1	220	1	334

244-2

HOSE CLAMP PLIER

- ▶ for simple self spanning wire hose clamps (e.g. washing machines)
- ▶ with rotatable jaws
- ▶ clamping range 40 mm
- ▶ nickel plated
- ▶ jaws made of high grade tool steel C45 / 1.0503



Code	Number	l/mm	Pieces	Weight/g
0244000020000	244-2	206	1	200

244-3

HOSE CLAMP PLIER

- ▶ for spring band clamps e.g. for VW, Audi and Opel
- ▶ with rotatable jaws
- ▶ clamping range 6-12 mm
- ▶ nickel-plated
- ▶ jaws made of high grade tool steel C45 / 1.0503



Code	Number	l/mm	Pieces	Weight/g
0244000030000	244-3	206	1	200

245-...

FLEXIBLE LINE CLAMP

- ▶ to pinch-off flexible hose lines without metallic tissue, to avoid leakage of fluids, e.g. during exchanging fuel or water of pumps, radiators or similar
- ▶ safe locking due to clamp ring
- ▶ stable plastic



Code	Number	for line Ø mm	l/mm	Pieces	Weight/g
0245000150000	245-15	0-15	155	6	48
0245000300000	245-30	0-30	185	6	84
0245000600000	245-60	19-57	250	6	130

411

LEAK OIL PLIER

- for plugging on and pulling down of difficult to access fuel return pipes on injecton nozzles
- 90° angled
- with burner hole and side cutter
- nonslip QUATROLIT®-2C-handles
- matt chrome plated
- ELORA-high grade tool steel C45 / 1.0503



Code	Number	l/mm	l/Inch	Pieces	Weight/g
0411000001000	411	190	7,5	1	234

374-...

FLAT NOSE PLIER

- extra-long for difficult to access areas
- straight or angled pattern
- grooved gripping surfaces
- ground, with dip insulated, black handles
- matt chrome plated
- ELORA-high grade tool steel C45 / 1.0503



Code	Number	Art.-Indication	l/mm	Pieces	Weight/g
0374000011000	374-1	straight	280	1	272
0374000021000	374-2	bent	280	1	276

586

AUTOMOTIVE LIGHT TESTER

- 10 mm long probe tip
- with protection cap
- cable with alligator clamp
- for voltage testing from 6-24 V
- not for use on vehicles with electrical components
- in a plastic bag



Code	Number	l/mm	Pieces	Weight/g
0586000000000	586	120	6	74

You will find grip pliers on page no. 474



You will find chain pipe or exhaust pipe cutters on page no. 355



294

ANTI-FREEZE TESTER

- for quick and accurate testing of the freezing point temperature of the coolant liquid at any outside temperature
- with 360° rotatable twin measuring element
- aspirate ball made of elastomer, stays elastic and full functional at any outside temperature
- hydrostatic block automatically avoids any leakage or reflow of air
- made of robust technical plastics



Code	Number	l/mm	Pieces	Weight/g
0294000000000	294	130	1	168

590-S

MINI HOOK SET

- 4 pcs.
- for removing and inserting of O-rings and sealing gaskets
- QUATROLIT®-2C-handles with suspension hole
- blade matt chrome-plated
- Chrome-Vanadium 58CrV4 / 1.8161



Code	Number	Pieces	Weight/g
0590500011000	590-S	1	176

1666

CREEPER

- professional pattern with lightly elevated head piece
- ergonomic pattern
- made of high tensile plastic
- capacity 130 kg
- 6 swivel castors, Ø 70 mm
- temperature range: -30 °C - +60 °C
- dimensions creeper:
H 115 x L 1030 x D 480 mm



Code	Number	Pieces	Weight/g
1666000000000	1666	1	6000

1666-Z

CREEPER FOR LYING AND SITTING

- professional finish
- can be converted from creeper to seat
- bolstered seating and lying area
- stable steel tube frame
- load capacity: 136,00 kg
- measurements creeper seat: H 145 x L 1025 x T 410 mm
- measurements seat: H 495 x L 550 x T 410 mm
- seat height approx: 48 cm



Code	Number	Pieces	Weight/g
1666000002000	1666-Z	1	9000



187-160

STRAP WRENCH

- for removing oil filters and clamping of round shaped parts
- max. parts diameter 160 mm
- non-slip fibre ribbon, width 22 mm
- plastic coated grip
- high grade tool steel



Code	Number	Handle Length mm	Pieces	Weight/g
0187001601000	187-160	230	1	338
0187001601001	187-E160	Spare strap	1	64

187-180

STRAP WRENCH

- for removing oil filters and clamping of round shaped parts
- especially appropriate for trucks, construction and agriculture machinery
- max. parts diameter 180 mm
- non-slip fibre ribbon, width 50 mm
- with 1/2" female square drive
- high grade tool steel



12,5

1/2"

Code	Number	Handle Length mm	Pieces	Weight/g
0187001801000	187-180	1/2"	1	407
0187001801001	187-E180	Spare strap	1	60

187-280

STRAP WRENCH

- for removing oil filters and clamping of round shaped parts
- especially appropriate for trucks, construction and agriculture machinery
- max. parts diameter 280 mm
- non-slip fibre ribbon, width 25 mm
- drop forged pattern
- ELORA-Chrome-Vanadium 31CrV3 / 1.2208



Code	Number	Handle Length mm	Pieces	Weight/g
0187002801000	187-280	280	1	520
0187002801001	187-E280	Spare strap	1	110

You will find flexible magnetic lifters on page no. 501



You will find inspection mirrors on page no. 501



236-1

OIL FILTER CHAIN WRENCH, UNIVERSAL

- for all common oil-, fuel filter and round couplings
- parts diameter 50-100 mm
- 32 chain links
- matt chrome-plated, black chain
- gunmetal finished
- 1-2"-female square drive according to DIN 3120



12,5

1/2"

Code	Number	Chain length mm		Pieces	Weight/g
0236000010000	236-1	400	1/2"	1	260

227

DRAIN PLUG WRENCH

- for loosening and tightening of oil female square drive screws
- matt chrome-plated
- Chrome-Vanadium 31CrV3 / 1.2208



Code	Number		l/mm	Pieces	Weight/g
0227000000000	227	8 und 10	285	6	335

190-...

FILTER WRENCH

- for all common oil-, fuel filter and round couplings
- with adjustable steel band
- plastic coated grip
- nickel-plated



Code	Number	Span Ø mm	Handle Length mm	Pieces	Weight/g
0190000603000	190-60	60-80	220	1	354
0190000803000	190-80	80-110	240	1	390

You will find claws
on page no. 501



874-2

OIL FILTER WRENCH

- ▶ suitable for oil filters in difficult to access areas
- ▶ 3 arms, for clockwise and counter-clockwise tightening
- ▶ female square drive according to DIN 3120-C 10, ISO 1174
- ▶ with adapter to female square drive according to DIN 3120-C 12,5, ISO 1174, with ball retaining groove
- ▶ external hexagon 21 mm
- ▶ chrome-plated, adapter gunmetal-finish
- ▶ high grade tool steel



10	12,5
3/8"	1/2"

Code	Number	max. oil filter Ø mm	Height mm	Pieces	Weight/g
0874000025100	874-2	65-120	65	1	407

770-L22

DRAIN PLUG WRENCH

- ▶ especially appropriate for Caterpillar vehicles
- ▶ with conic external hexagon size 22-24,5 mm and 28,5-31 mm
- ▶ 1-2"-female square drive according to DIN 3120
- ▶ matt chrome-plated
- ▶ ELORA-Chrome-Vanadium 31CrV3 / 1.2208



12,5
1/2"

Code	Number	l/mm	Pieces	Weight/g
0770022002000	770-L22	44	6	180

875

TRUCK AIR FILTER WRENCH

- ▶ for loosening of air filters
- ▶ 3 arms
- ▶ black coated
- ▶ high grade tool steel
- ▶ female square drive according to DIN 3120-C 12,5, ISO 1174, with ball retaining groove



12,5
1/2"

Code	Number	for air filter Ø mm	Height mm	Pieces	Weight/g
0875000005100	875	75-130	85	1	961

770-L21

RADIATOR DRAIN SOCKET

- ▶ especially appropriate for Caterpillar vehicles
- ▶ slot width 11 mm
- ▶ female square drive according to DIN 3120-C 12,5, ISO 1174 with ball retaining groove
- ▶ matt chrome-plated
- ▶ ELORA-Chrome-Vanadium 31CrV3 / 1.2208



12,5
1/2"

Code	Number	l/mm	Pieces	Weight/g
0770021002000	770-L21	40	6	55

463

GLOW PLUG PLIER

- straight edition
- for plugging on and pulling down of deep-seated glow plugs
- nonslip QUATROLIT®-2C-handles
- matt chrome plated
- ELORA-high grade tool steel C45 / 1.0503



Code	Number	l/mm	l/Inch	Pieces	Weight/g
0463000005100	463	230	9	1	289

464-...

SPARK PLUG PLIER

- hooked jaws
- for difficult to pull down spark plug sockets
- matt chrome plated
- nonslip QUATROLIT®-2C-handles
- ELORA-high grade tool steel C45 / 1.0503



Code	Number	l/mm	l/Inch	Pieces	Weight/g
0464002001100	464-200Bl	200	8	1	247

465-...

SPARK PLUG PLIER

- for difficult to access spark plug sockets
- jaw length 50mm
- Bl: matt chrome plated
- Al: gunmetal finished
- nonslip QUATROLIT®-2C-handles
- ELORA-high grade tool steel C45 / 1.0503



Code	Number	Jaw length mm	l/mm	l/Inch	Pieces	Weight/g
0465002305100	465-230Al	50	240	9,5	1	280
0465002301100	465-230Bl	50	240	9,5	1	275
0465003005100	465-300Al	50	300	12	1	350
0465003001100	465-300Bl	50	300	12	1	353

1115

GLOW PLUG RATCHET

- for mounting and dismounting of glow plugs in constricted room
- curved pattern, reversible
- matt chrome-plated, polished
- special steel



Code	Number	mm	l/mm	Pieces	Weight/g
1115000000000	1115	8 x 12	255	6	159

218-.../220-...

TUBULAR SPARK PLUG WRENCH

- for spark plugs of size 16 mm (5/8" AF)
- to operate with tommy bar ELORA-No. 229D
- female square drive according to DIN 3120-C 10, ISO 1174 respectively DIN 3120-C 12,5, ISO, with ball retaining groove
- made of seamless precision tube
- hardened, matt chrome-plated
- high grade tool steel C45/1.0503
- tommy bars are not included



10	12,5
3/8"	1/2"



Code	Number	Ø		l/mm	Pieces	Weight/g
0218016271000	218-16x270	3/8"	M10	270	6	200
0220016141000	220-16x145	1/2"	M10	145	6	95
0220016271000	220-16x270	1/2"	M10	270	6	200

219

TUBULAR SPARK PLUG WRENCH

- to operate with tommy bar ELORA-No. 229D
- with rubber insert 20,8 mm
- hollow shaft made of seamless tube
- hardened
- matt chrome-plated
- high grade tool steel C45/1.0503
- tommy bars are not included



Code	Number	mm		l/mm	Pieces	Weight/g
0219000000000	219	16 x 20,8 (5/8 x 13/16 AF)	M10, M14	190	6	210

229D

TOMMY BAR

- for tubular spark plug wrench ELORA-No. 218, 219, 220
- hardened, matt chrome-plated
- ELORA-Chrome-Vanadium 31CrV3 / 1.2208



Code	Number	Ø mm	l/mm	Pieces	Weight/g
0229000000000	229D	8	185	6	74

222-...

SPARK PLUG WRENCH

- pattern with swivelling actuating bracket
- hardened, chrome-plated
- ELORA-Chrome-Vanadium 31CrV3 / 1.2208



Code	Number	mm		l/mm	Pieces 	Weight/g
0222000161000	222-16	16x20,8 (5/8x13/16 AF)	M10, M14	215	4	200
0222000211000	222-20,8	20,8x26 (13/16x1 AF)	M14, M18	215	4	245

871TZ-...

SPARK PLUG SOCKET 3/8", HEXAGON

- extra deep, with rubber insert
- chrome-plated, polished
- knurled
- female square drive according to DIN 3120-C 10, ISO 1174, with ball retaining groove
- ELORA-Chrome-Vanadium 31CrV3 / 1.2208



10

3/8"



Code	Number	mm		l/mm	Pieces 	Weight/g
0871001602000	871TZ-16	16,0 (5/8 AF)	M10	70	6	106
0871001802000	871TZ-18	18,0 (11/16 AF)	M12	70	6	115
0871002082000	871TZ-20,8	20,8 (13/16 AF)	M14	70	6	124

You will find joint socket wrenches with t-handle on page no. 118

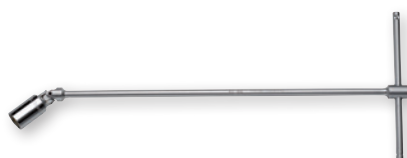

871TMG-...

SPARK PLUG SOCKET 3/8", HEXAGON

- ▶ extra deep, with permanent magnet
- ▶ chrome-plated, polished
- ▶ knurled
- ▶ female square drive according to DIN 3120-C 10, ISO 1174, with ball
- ▶ retaining groove
- ▶ ELORA-Chrome-Vanadium 31CrV3 / 1.2208



10



3/8"



Code	Number	mm		l/mm	Pieces	Weight/g
0871011602300	871TMG-16	16,0 (5/8 AF)	M10	70	6	115
0871011802300	871TMG-18	18,0 (11/16 AF)	M12	70	6	115
0871012082300	871TMG-20,8	20,8 (13/16 AF)	M14	70	6	154

771LTZ-...

SPARK PLUG SOCKET 1/2", HEXAGON

- ▶ extra deep, with rubber insert and bore hole Ø 9 mm
- ▶ chrome-plated, polished
- ▶ knurled
- ▶ female square drive according to DIN 3120-C 12,5, ISO 1174, with ball retaining groove
- ▶ ELORA-Chrome-Vanadium 31CrV3 / 1.2208



12,5



1/2"



Code	Number	mm		Ø mm	l/mm	Pieces	Weight/g
0771031602000	771LTZ-16	16,0 (5/8 AF)	M10	22	80	6	165
0771031802000	771LTZ-18	18,0 (11/16 AF)	M12	25	80	6	170
0771032082000	771LTZ-20,8	20,8 (13/16 AF / 7/16 WW)	M14	27	80	6	180

771LMG-...

SPARK PLUG SOCKET 1/2", HEXAGON

- ▶ extra deep, with permanent magnet
- ▶ chrome-plated, polished
- ▶ knurled
- ▶ female square drive according to DIN 3120-C 12,5, ISO 1174, with ball retaining groove
- ▶ ELORA-Chrome-Vanadium 31CrV3 / 1.2208



12,5



1/2"



Code	Number	mm		Ø mm	l/mm	Pieces	Weight/g
0771031602300	771LMG-16	16,0 (5/8 AF)	M10	22	80	6	170
0771031802300	771LMG-18	18,0 (11/16 AF)	M12	25	80	6	175
0771032082300	771LMG-20,8	20,8 (13/16 AF / 7/16 WW)	M14	27	80	6	185

770-L20-...

SPARK PLUG SOCKET 1/2", BI-HEXAGON

- ▶ extra deep, with rubber insert
- ▶ chrome-plated, polished
- ▶ knurled
- ▶ female square drive according to DIN 3120-C 12,5, ISO 1174, with ball retaining groove
- ▶ ELORA-Chrome-Vanadium 31CrV3 / 1.2208



12,5



1/2"



Code	Number	mm		l/mm	Pieces	Weight/g
0770602012000	770-L20-1	16,0 (5/8 AF)	M10	100	1	193
0770602022000	770-L20-2	20,8 (13/16 AF)	M14	100	1	185

249

CONTACT FILE

- for cleaning and adjusting of spark plug contacts
- Cut 2 second
- high grade tool steel C45/1.0503



Code	Number	Measurement mm	Pieces 	Weight/g
0249000000000	249	150x8x0,8	12	10

249-S6

CONTACT FILE SET

- 6 pcs.
- for cleaning and adjusting of spark plug contacts
- in a plastic storage wallet
- Cut 2, second
- high grade tool steel C45/1.0503



Code	Number	Pieces 	Weight/g
0249500060000	249-S6	6	64

251

SPARK PLUG CLEANING BRUSH

- for cleaning of spark plug contacts
- corrugated brass wire bristles, 3 rows
- wooden handle







Code	Number	Working Surface mm	l/mm 	l/Inch 	Pieces 	Weight/g
0251000000000	251	45 x 18	150	8	12	40

580-45

SPARK PLUG TESTER

- ▶ for function testing of spark plugs with one electrode
- ▶ plastic handle with metal clip
- ▶ blade made of Chrome-Vanadium 31CrV3 / 1.2208



Code	Number	Edge mm	 mm	 mm	Pieces 	Weight/g 
0580000451000	580-45	3	45	120	6	14

770-LTD

SOCKET FOR INJECTION NOZZLE

- ▶ appropriate for injection nozzles on Diesel engine vehicles
- ▶ size 27 mm, recessed internal contour
- ▶ hot-forged
- ▶ chrome-plated
- ▶ knurled
- ▶ female square drive according to DIN 3120-C 12,5, ISO 1174, with ball retaining groove
- ▶ ELORA-Chrome-Vanadium 31CrV3 / 1.2208

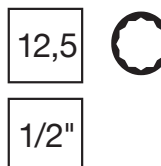





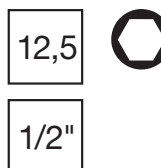

Code	Number	 mm	l/mm 	Pieces 	Weight/g 
0770035701000	770-LTD	27	80	1	267

776L-9

SOCKET FOR LAMBDA OXYGEN SENSOR

- ▶ extra-long pattern
- ▶ for lambda oxygen sensor with fix mounted cable
- ▶ internal hexagon size 22 mm
- ▶ slotted for passing the cable
- ▶ female square drive according to DIN 3120-C 12,5, ISO 1174, with ball retaining groove
- ▶ Chrome-Molybdenum 42CrMo4 / 1.7225



Code	Number	 mm	 mm	l/mm 	Pieces 	Weight/g 
0776000095100	776L-9	1/2"	22	150	1	367

You will find **craw foot spanners** on page no. 142



You will find **impact sockets 1/2", extra deep** on page no. 205



790LTP...

IMPACT SOCKET 1/2", HEXAGON

- for power tools
- extra deep with, with plastic sleeve
- for wheel mounting, plastic sleeve to protect the rims from scratches
- coloured size identification
- female square drive according to DIN 3121-H 12,5, ISO 1174
- special steel

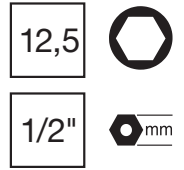
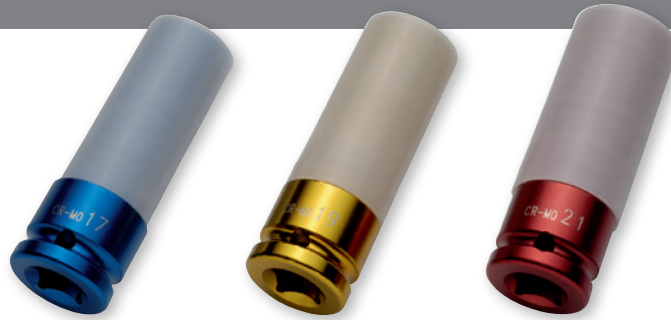

Code	Number	Colour	l/mm	Locking Pin	Locking Ring	Pieces	Weight/g
0790026155101	790LTP-15	dark green	85	7903-25	7904-24	6	200
0790026175101	790LTP-17	blue	85	7903-25	7904-24	6	200
0790026195101	790LTP-19	yellow	85	7903-25	7904-24	6	220
0790026215101	790LTP-21	red	85	7903-25	7904-24	6	240
0790026225101	790LTP-22	green	85	7903-25	7904-24	6	260

790-LTPS3

IMPACT SOCKET SET 1/2", HEXAGON

- 3 pcs., in plastic box
- extra deep, plastic sleeve, in plastic box
- for wheel mounting, plastic sleeve to protect the rims from scratches
- for power tools
- coloured size identification
- female square drive according to DIN 3121-H 12,5, ISO 1174
- special steel

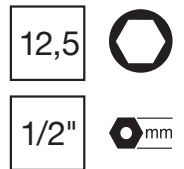

Code	Number	Contents	Pieces	Weight/g
0790526005100	790-LTPS3	790LTP- 17 mm blue, 19 mm yellow, 21 mm red	6	833

790DW-...

IMPACT SOCKET 1/2", THIN WALLED, HEXAGON

- for power tools
- extra deep
- suitable for deep lying bolts
- square drive according to DIN 3121-G12,5, ISO1174
- special steel, phosphatized

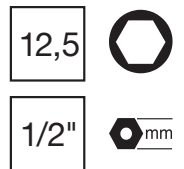
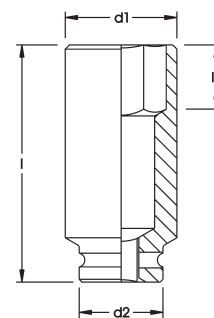

Code	Number	l/mm	l1 mm	d1 mm	d2 mm	Locking Pin	Locking Ring	Pieces	Weight/g
0790000175101	790DW-17	52	24	24,5	30	7903-25	7904-24	6	130
0790000195101	790DW-19	52	24	27	30	7903-25	7904-24	6	140
0790000215101	790DW-21	52	24	30	30	7903-25	7904-24	6	160

170-...

WHEEL NUT WRENCH

- for loosening and tightening of wheel nuts and wheel bolts of trucks
- forged pattern
- additional 13/16 AF female square drive within the size of 32 mm, for operating of wheel bolts with male square drive
- to operate with tommy bar ELORA-No. 171
- nickel-plated
- special tool steel

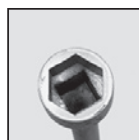

Code	Number	mm	l/mm	Pieces	Weight/g
0170000243000	170-24	24 x 27	400	1	1370
0170000273000	170-27	27 x 32 (1.1/16 AF)	400	1	1519
0170000286100	170-28	28 x 33	400	1	1516
0170000303000	170-30	30 x 32 (1.1/6 AF)	400	1	1686
0170000323000	170-32	32 (1.1/16 AF) x 38 (1.1/4 AF)	400	1	1658

171-...

TOMMY BAR FOR WHEEL NUT WRENCH

- to operate the wheel nut wrench ELORA-No. 170
- nickel-plated
- Chrome-Vanadium 31CrV3 / 1.2208



Code	Number	Ø mm	l/mm	Pieces	Weight/g
0171000011000	171-500	18	500	1	980
0171000000000	171-600	18	600	1	1175

185-...

WHEEL NUT WRENCH

- bent pattern with hub cap puller
- matt chrome-plated
- Chrome-Vanadium 31CrV3 / 1.2208



Code	Number	mm	l/mm	Pieces	Weight/g
0185000171000	185-17	17	375	3	620
0185000191000	185-19 / 3/4	19 (3/4 AF)	400	3	750

195WS-...

FOUR WAY WHEEL NUT WRENCH

- ▶ for cars, light trucks and agricultural machinery
- ▶ silver coated
- ▶ high grade tool steel
- ▶ pattern according to DIN 3119, ISO 6788

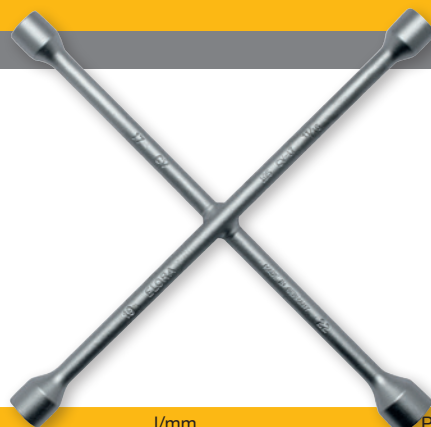

Code	Number	Size	l/mm	Pieces	Weight/g
0195000176100	195WS-17	17, 19, 22, 13/16 AF	410	1	1280
0195100236100	195WS-1/2	17, 19, 22, 1/2" male square drive	410	1	1280

195CV-17, 195CV-5/8

FOUR WAY WHEEL NUT WRENCH

- ▶ for cars, light trucks and agricultural machinery
- ▶ heavy-duty pattern
- ▶ matt chrome-plated
- ▶ Chrome-Vanadium 31CrV3 / 1.2208
- ▶ pattern according to DIN 3119, ISO 6788

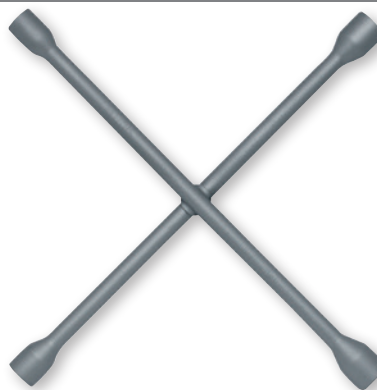

Code	Number	Size	l/mm	Pieces	Weight/g
0195000171000	195CV-17	17, 19, 22, 11/16 AF	380	1	1300
0195100261000	195CV-5/8	5/8, 11/16, 3/4, 7/8 AF	380	1	1300

195CV-...

FOUR WAY WHEEL NUT WRENCH

- ▶ for loosening and tightening of wheel nuts and wheel bolts of trucks and tractors
- ▶ heavy-duty pattern
- ▶ matt chrome-plated
- ▶ Chrome-Vanadium 31CrV3 / 1.2208
- ▶ pattern according to DIN 3119, ISO 6788

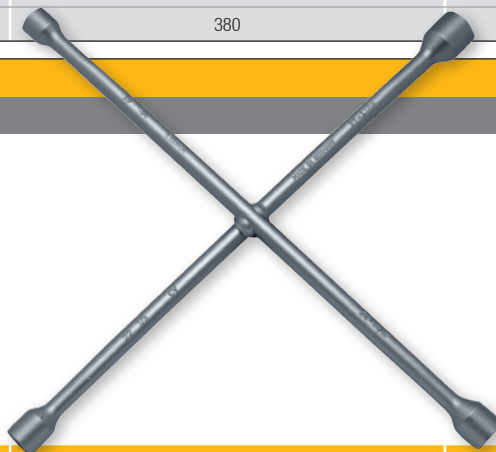

Code	Number	Size	l/mm	Pieces	Weight/g
0195000271000	195CV-27 / 1.1/16	19, 22, 24, 27, 3/4, 7/8, 15/16, 1.1/16	600	1	3200
0195000321000	195CV-32	24, 27, 30, 32	750	1	4950
0195000381000	195CV-38 / 1.1/2	24, 27, 32, 38, 15/16, 1.1/16, 1.1/4, 1.1/2	750	1	4950
0195100281000	195CV-3/4	24, 27, 32, 3/4	750	1	4950

You will find sockets 1/2", extra deep on page no. 155



196-...

FOUR WAY WHEEL NUT WRENCH

- for loosening and tightening of wheel nuts and bolts of trucks, tractors and construction machinery
- heavy-duty pattern due to forged centrepiece
- dimensions: 750 x 750 mm
- additional 13 / 16" female square within the size 32 mm for operating of wheel nuts with male square
- matt chrome-plated
- Chrome-Vanadium 31CrV3 / 1.2208
- pattern according to DIN 3119, ISO 6788



Code	Number	Size	l/mm	Pieces	Weight/g
0196000321000	196-32	24, 27, 30, 32	750	1	6200
0196000381000	196-38	24, 27, 32, 38	750	1	6200
0196100281000	196-3/4	24 ,27, 32, 3/4" male square pattern	750	1	6200

You will find axial grip pliers on page no. 356-359

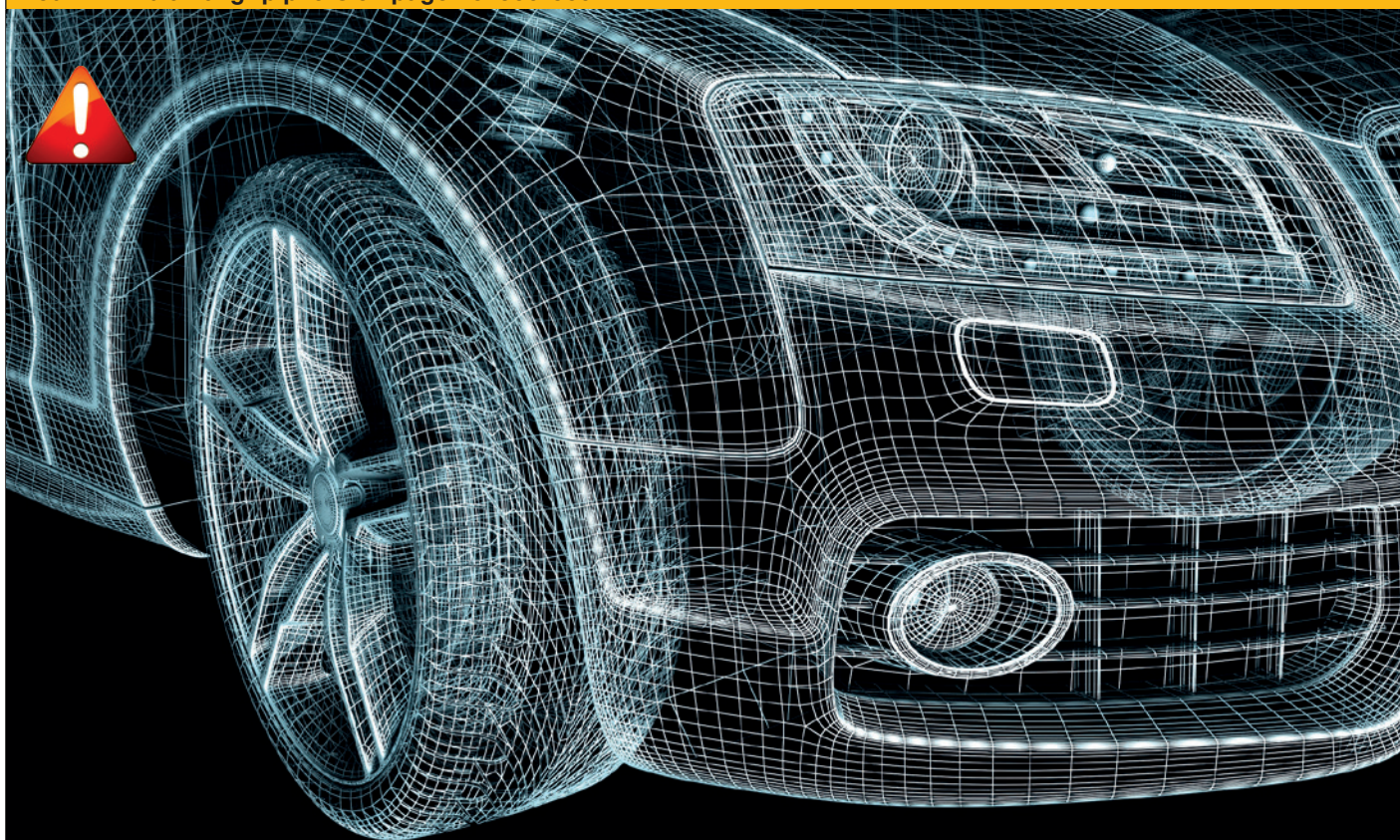

163

TYRE LEVER

- especially suitable for tubeless tyres
- heavy-duty pattern
- matt chrome-plated
- Chrome-Vanadium 31CrV3 / 1.2208



Code	Number	l/mm	Pieces	Weight/g
0163000000000	163	450	6	610

165-...

TYRE LEVER

- especially suitable for car tyres
- drop forged pattern with profile shaft
- matt chrome-plated
- Chrome-Vanadium 31 CrV3 / 1.2208



Code	Number	l/mm	Pieces	Weight/g
0165003001000	165-300	300	6	240
0165004001000	165-400	400	6	375
0165005001000	165-500	500	6	610
0165006001000	165-600	600	6	850

186

TYRE LEVER

- especially suitable for truck tyres
- heavy-duty pattern
- matt chrome-plated
- Chrome-Vanadium 31CrV3 / 1.2208



Code	Number	l/mm	Pieces	Weight/g
0186000000000	186	600	3	1400

243MB

BALANCE WEIGHT PLIER

- for loosening, tightening and cutting of balance weights on rims
- for setting retaining springs on balance weights
- chrome-plated
- Chrome-Vanadium 31CrV3 / 1.2208



Code	Number	l/mm	Pieces	Weight/g
0243000001000	243MB	240	1	390

198

TYRE TREAD GAUGE

- for measuring the tyre tread
- measuring range 0-30 mm
- reading accuracy 0,1 mm (vernier scale 1/10 mm)
- length of locating surface 23 mm
- solid brass



Code	Number	l/mm	Pieces	Weight/g
0198000000000	198	100	1	58

167-...

VALVE ROTATOR

- for screwing on and off the valve inserts as well as for pushing the valve pin in tyre valves
- plastic grip



Code	Number	l/mm	Pieces	Weight/g
0167000010000	167-1	130	1	120

167

TYRE PRESSURE GAUGE

- with cranked measuring intake for VG8 screw thread
- with push-button for resetting the indicator and rotatable for zero regulation
- measuring scale 0-10 bar, resp. 0-140 PSI
- pressure indication in BAR and PSI
- accuracy $\pm 1\%$ of the value



Code	Number	l/mm	Pieces	Weight/g
0167000000000	167	270	1	220

302

BRAKE PISTON RESET TOOL

- for resetting the pistons in brake disc callipers without screw thread reset adjuster
- suitable for all common types of vehicles
- nickel-plated, jaws gunmetal-finish
- high grade tool steel C45 / 1.0503



Code	Number	l/mm	Pieces	Weight/g
0302000000000	302	205	1	1558

292

FILE FOR BRAKE SERVICE

- for removing braking dust and rust in the brake callipers of car disc brakes
- rough milled
- 2-C-handle
- Tool steel 140Cr3/1.2008



Code	Number	l/mm	Measurement mm	Pieces	Weight/g
0292000000001	292	230	150 x 16 x 4	1	141

292-1

FILE FOR BRAKE SERVICE

- for removing braking dust and rust in the brake callipers of car disc brakes
- 4-sides rough milled
- plastic handle
- Tool steel 140Cr3/1.2008



Code	Number	l/mm	Measurement mm	Pieces	Weight/g
0292000010000	292-1	260	150 x 10 x 10	6	84

293BS

BRUSH FOR BRAKE SERVICE

- for removing braking dust and rust in the brake callipers of car disc brakes
- narrow pattern, width 12 mm
- bristles made of straight steel wire
- 2C-handle



Code	Number	l/mm	Pieces	Weight/g
0293000100000	293BS	240	6	100

293

BRUSH FOR BRAKE SERVICE

- for removing braking dust and rust in the brake callipers of car disc brakes
- narrow, bent pattern
- plastic handle
- bristles made of corrugated steel wire



Code	Number	l/mm	l/Inch	Pieces	Weight/g
0293000000000	293	265	10.1/2	6	80

480-...

BRAKE SPRING PLIER

- for removing and replacing of brake shoe return springs in drum brakes
- especially suitable for riveted brake linings
- nickel-plated
- Chrome-Vanadium 59CrV4 / 1.2242



Code	Number	l/mm	Pieces	Weight/g
0480002151000	480-215	215	1	300
0480003301000	480-330	330	1	419

480-340

BRAKE SPRING PLIER

- for removing and replacing of brake shoe return springs in drum brakes
- with a moveable claw, especially suitable for glued brake linings
- nickel-plated, with black coated handles
- Chrome-Vanadium 59CrV4 / 1.2242



Code	Number	l/mm	Pieces	Weight/g
0480003401000	480-340	340	1	535

329-...

SEPARATOR "FORK"-TYPE

- for removing connecting rods, ball rods, drop arms etc.
- massive forged pattern
- handle knurled
- zinc-plated
- high grade tool steel



Code	Number	Fork opening mm	l/mm	Pieces	Weight/g
0329000186100	329-18	18	330	1	846
0329000236100	329-23	23	330	1	916
0329000316100	329-31	31	330	1	1036

You will find precision vernier callipers for brake disc on page no. 408

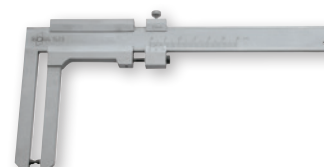

1601-1608

PLANISHING, BUMPING AND DINGING HAMMERS

- forged, blue lacquered, faces grounded or chequered
- high grade tool steel C 45 / 1.0503, ash handles

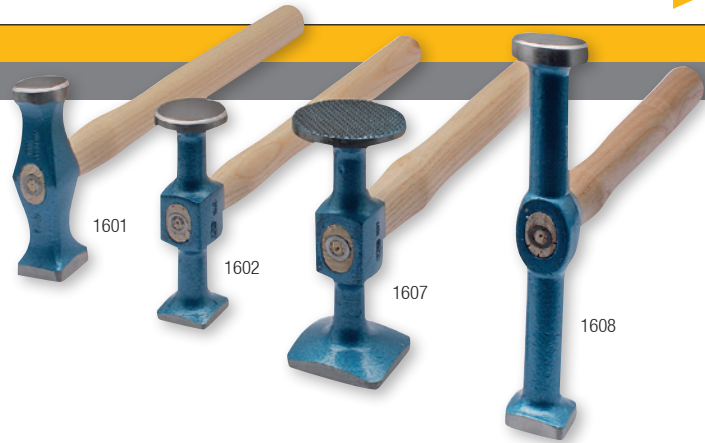

Code	Number	round hammer head Ø mm	□ mm	Length hammer head Ø mm	l/mm ┌─┐	Productinformation	Pieces ☞	Weight/g ⚖
1601000000000	1601	27	27	105	300	Planishing hammer	1	450
1602000000000	1602	32	25	105	300	Bumping hammer	1	300
1603000000000	1603	32 milled	25	105	300	Bumping hammer	1	300
1604000000000	1604	40	35	95	310	Bumping hammer	1	380
1605000000000	1605	40 milled	35	95	310	Bumping hammer	1	380
1606000000000	1606	46	40	115	335	Bumping hammer	1	500
1607000000000	1607	46 milled	40	115	335	Bumping hammer	1	600
1608000000000	1608	32	25	165	320	Dinging hammer	1	420

1612-1618

PICK AND BUMPING HAMMERS

- forged
- blue lacquered, faces ground
- ash handle
- high grade tool steel C45 / 1.0503



Code	Number	round hammer head Ø mm	□ mm	Length hammer head Ø mm	l/mm ┌─┐	Productinformation	Pieces ☞	Weight/g ⚖
1612000000000	1612	40	20 x 3	160	300	Pick hammer	1	450
1615000000000	1615	33	36 x 10	160	290	Double bumping hammer	1	500
1618000000000	1618	30	25 x 5	115	290	Bumping hammer	1	300

1609-1616

DINGING, PICK AND EMBOSsing HAMMERS

- forged
- blue lacquered, faces ground
- ash handle
- high grade tool steel C45 / 1.0503



Code	Number	Hammer head Ø mm	Length hammer head Ø mm	l/mm ┌─┐	Productinformation	Pieces ☞	Weight/g ⚖
1609000000000	1609	40 x 18	155	300	Dinging hammer	1	460
1610000000000	1610	40 x 10	155	300	Pick and Finishing hammer	1	410
1611000000000	1611	40 x spitz	165	300	Pick hammer, special shape	1	440
1616000000000	1616	40 x spitz	165	400	Embossing hammer	1	400

1613-1619

BUMPING HAMMERS

- forged
- blue lacquered, faces ground
- ELORA No. 1619 with replaceable rubber face ELORA No. 1619E
- ash handle
- high grade tool steel C45 / 1.0503



Code	Number	Hammer head Ø mm	Length hammer head Ø mm	l/mm	Productinformation	Pieces	Weight/g
1613000000000	1613	28	160	330	Fender bumping hammer	1	680
1614000000000	1614	40 x 30	155	300	Bumping hammer	1	430
1619000000000	1619	55 x 33	140	395	Combination mallet and Bumping hammer with replaceable rubber face	1	1000
1619000007000	1619E	55	50	-	Spare rubber face for ELORA-No. 1619	1	140

1621-1636

HAND ANVIL

- forged
- blue lacquered, faces ground
- high grade tool steel C45 / 1.0503

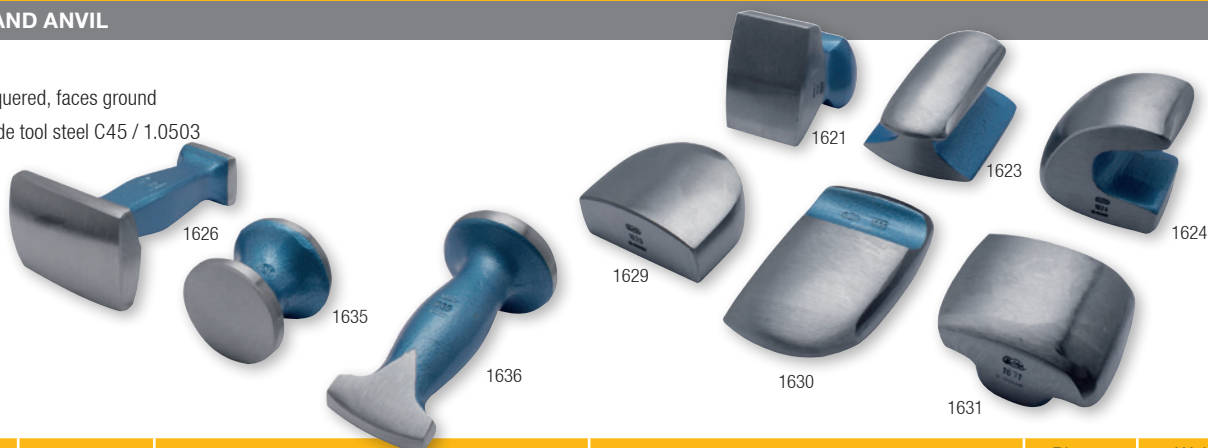

Code	Number	Productinformation	Measurement mm	Pieces	Weight/g
1621000000000	1621	General purpose dolly	75 x 63 x 55	1	1200
1623000000000	1623	Anvil dolly	62 x 80 x 70 x 100 x 40	1	1400
1624000000000	1624	Fender dolly	68 x 54 x 68	1	1200
1626000000000	1626	Dome dolly	125 x 85 x 55 x 43 x 33	1	1150
1629000000000	1629	Heel dolly	80 x 60 x 35	1	1050
1630000000000	1630	Toe dolly	105 x 66	1	950
1631000000000	1631	General purpose dolly	74 x 61 x 49	1	1100
1635000000000	1635	Diabolo dolly	60 x Ø 56 x Ø 56	1	750
1636000000000	1636	Round anvil	130 x 48 x Ø 58	1	930

You will find rubber mallets on page no. 372



1622-1639

WEDGE DOLLY

- forged
- blue lacquered, faces ground or checkquered
- high grade tool steel C45 / 1.0503

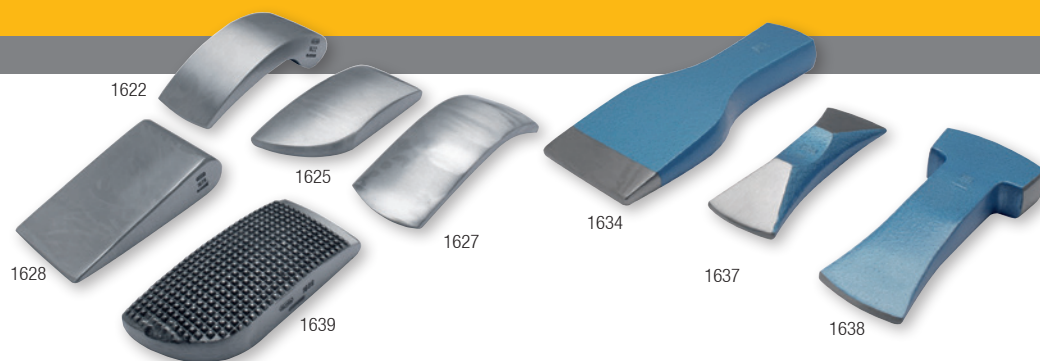

Code	Number	Productinformation	Measurement mm	Pieces	Weight/g
1622000000000	1622	Anvil dolly	130 x 55	1	950
1625000000000	1625	Fender dolly	120 x 56 x 21	1	760
1627000000000	1627	Curved dolly	145 x 52	1	550
1628000000000	1628	Grid dolly	112 x 64	1	900
1634000000000	1634	Wedge dolly	192 x 45 x 77	1	1600
1637000000000	1637	Wedge dolly	118 x 42	1	450
1638000000000	1638	Wedge dolly	135 x 48 x 46 x 26	1	850
1639000000000	1639	Grid dolly	125 x 55 x 25	1	1100

1645-1652

BODY SPOON AND BENDING IRON

- forged
- blue lacquered, faces ground
- high grade tool steel C45 / 1.0503

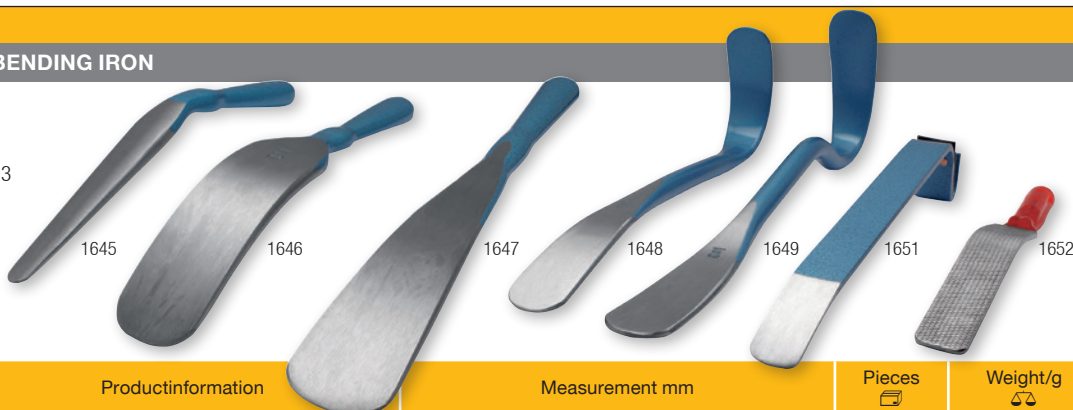

Code	Number	Productinformation	Measurement mm	Pieces	Weight/g
1645000000000	1645	Body spoon, light	270 x 30 x 18	2	550
1646000000000	1646	Body spoon, medium	300 x 50	2	850
1647000000000	1647	Body spoon, heavy	390 x 25 x 58	2	950
1648000000000	1648	Prybumping spoon, light	440 x 58 x 150	1	1900
1649000000000	1649	Prybumping spoon, heavy	500 x 58	1	2200
1651000000000	1651	Bending iron, leather insert	400 x 25 x 58	2	1000
1652000000000	1652	chequered tightening spoon	315 x 40	2	500

1650S6

BUMPING TOOL SET

- 6 pcs.
- in a black metal box 310 x 185 x 70 mm



Code	Number	Contents	Pieces	Weight/g
1650500067000	1650S6	1601 Planishing hammer 1626 Dome dolly 1629 Heel dolly 1635 Diabolo dolly 1636 Round anvil 1637 Wedge dolly	1	7200

1650S12

BUMPING TOOL SET

- 12 pcs.
- in a black metal box 310 x 185 x 70 mm



Code	Number	Contents	Pieces	Weight/g
1650500127000	1650S12	1601 Planishing hammer 1613 Fender bumping hammer 1615 Double bumping hammer 1626 Dome dolly 1629 Heel dolly 1635 Diabolo dolly 1636 Round anvil 1637 Wedge dolly 1640 Adj. file holder, without file 1641-7 File blade, medium, radial milled 1651 Bending iron, leather insert 1660-35 Soft faced hammer, 35 mm	1	12000

1644-20

PUNCH AND JOGGLER/ FLANGING TOOL

- for punching of body panels for MIG / MAG welding and flanging metal edges on overlap of seams
- flanging capacity: 11 mm, jaw width: 23 mm, stamp
- diameter: 5 mm
- for metal sheet up to 1 mm
- with swivel head and replaceable stamp
- lacquered, handles with PVC grips
- high grade tool steel



Code	Number	l/mm	Pieces	Weight/g
1644000207000	1644-20	290	1	1221

You will find seaming or bending pliers on page no. 336



You will find radiator drain sockets on page no. 436



355-...

SPOT WELD DRILL

- for exact drilling of spot welds
- with self-cutting centre tip
- HSS



Code	Number	mm	l/mm	Pieces	Weight/g
0355000061000	355-6	6	66	12	19
0355000081000	355-8	8	79	12	25

354-...

SPOT WELD CUTTER

- to mill out spot welds without warping or tearing of the metal sheet
- compatible for standard drills
- interchangeable double-sided usable cutting crown
- HSS



Code	Number	l/mm	Productinformation	Pieces	Weight/g
0354000000000	354	70	Spot-weld cutter	12	20
0354000000001	354-1	-	Spare part cutter 10 mm	12	5
0354000000002	354-2	-	Spare part centre pin	12	3

You will find slit or body chisels
on page no. 378



You will find axial or grip pliers
on page no. 350-356



1640

ADJUSTABLE FILE HOLDER

- ▶ for file blades ELORA-No. 1641 (delivery without file blade)
- ▶ adjustable pattern with clamping screw
- ▶ Aluminium



Code	Number	l/mm	Pieces	Weight/g
1640000000000	1640	360	1	559

1640H

FILE HOLDER FOR CAR BODY FILES

- ▶ for file blades ELORA-No. 1641 (delivery without file blade)
- ▶ wood



Code	Number	l/mm	Pieces	Weight/g
164000008000	1640H	535	1	349

1641-...

CARBODY FILE BLADE

- ▶ for file holder ELORA-No. 1640 and 1640H

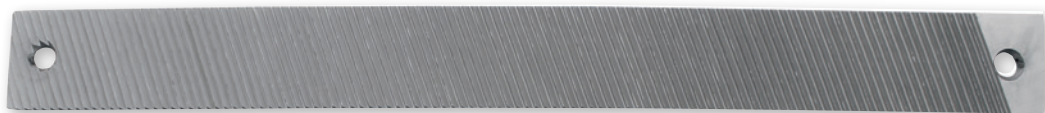

Code	Number	Productinformation	Teeth/Inch	l/mm	Pieces	Weight/g
1641000027000	1641-2	carbody file blade, coarse, diagonal milled	9	350	6	295
1641000037000	1641-3	medium, diagonal milled	12	350	6	285
1641000047000	1641-4	fine, diagonal milled	21	350	6	270
1641000067000	1641-6	coarse, radial milled	9	350	6	235
1641000077000	1641-7	medium, radial milled	12	350	6	255
1641000087000	1641-8	coarse pattern, radial milled, half round	9	350	6	225

290-1

DOOR PANNELLING EXTRACTION TOOL

- ▶ for dismantling of the securing clips
- ▶ jaw open 6 mm
- ▶ zinc-plated, black plastic handles
- ▶ high grade tool steel
- ▶ matt chrome-plated



Code	Number	l/mm	Pieces	Weight/g
0290000100000	290-1	250	6	130

253

DOOR PANELLING EXTRACTION PLIER

- for dismantling of the securing clips on door panelling, garnish mouldings and bumpers
- nickel-plated, jaws and joint gunmetal-finish
- high grade tool steel



Code	Number	l/mm	Pieces	Weight/g
0253000000000	253	230	1	243

239

DOOR SPRING CLIP REMOVER

- for removing and inserting of the securing-clips of window cranks
- nickel-plated, jaws gunmetal-finish
- jaws made of high grade tool steel C75 / 1.0605



Code	Number	l/mm	Pieces	Weight/g
0239000000000	239	210	1	117

318-S5

MOUNTING WEDGE

- 5 pcs.
- carton box packed
- suitable for works on panelling, dash board and garnish mouldings
- special plastic POM, black



Code	Number	Contents	l/mm	Pieces	Weight/g
0318500051000	318-S5	Garnish moulding plastic-wedge, L= 195 mm, B= 30 mm Garnish moulding plastic-wedge, L= 195 mm, B= 60 mm Garnish moulding combination-wedge, L= 210 mm, B= 26 mm Garnish moulding wedge with felt, L= 250 mm, B= 20 mm Splitting and angular wedge, L= 250 mm, B= 20 mm	205	1	511

280-...

SUCTION LIFTER

- for lifting and carrying material with plain, gas-tight surfaces
- suction mechanism with security locking
- acid- and oil resistant
- ELORA-No. 280-40: one suction cup
- ELORA-No. 280-80: two suction cups
- plastic housing, suction cups made of rubber



Code	Number	Lifting Capacity	l/mm	Pieces	Weight/g
0280000400000	280-40	30 kg	120	1	372
0280000800000	280-80	60 kg	325	1	745

280G

SUCTION LIFTER WITH FLEXIBLE HEADS

- especially suitable for car glass and domed surfaces
- suction mechanism with security locking
- acid- and oil resistant
- plastic housing, suction cups made of rubber



Code	Number	Lifting Capacity	l/mm	Pieces	Weight/g
0280010800000	280G	45 kg	390	1	831

You will find screwdriver, extra long on page no. 271



You will find TORX® hexagonal key with t-handle, extra long on page no. 261



270

BATTERY TESTER

- ▶ for diagnostics of the charging system and the voltage status of car and motorcycle batteries
- ▶ measuring range 6 and 12 Volt up to 1000 CCA
- ▶ easy to read scale, for up to 100 Ampere



Code	Number	Pieces	Weight/g
0270000000000	270	1	1394

270-D

BATTERY TESTER, DIGITAL

- ▶ for diagnostics of the charging system and starter motor system
- ▶ tests 12V battery ratings of 200 to 1000 CCS range
- ▶ easy to use: push one button to complete the test within 10 seconds
- ▶ bright LED digital display



Code	Number	Pieces	Weight/g
0270000001000	270-D	1	1480

252

BATTERY TERMINAL BRUSH

- ▶ with external round brush to clean the cable clamps and internal brush for cleaning battery terminals
- ▶ packed in plastic box



Code	Number	l/mm	Pieces	Weight/g
0252000000000	252	120	10	58

277

BATTERY ACID TESTER

- for testing the acid density on conventional batteries with screw caps
- with areometer



Code	Number	l/mm	Pieces	Weight/g
0277000000000	277	350	1	131

287

BATTERY ACID FILLER

- for filling conventional batteries with screw caps
- with rubber ball and PVC tube
- acid-resistant



Code	Number	l/mm	Pieces	Weight/g
0287000000000	287	150	1	40

278

PLASTIC BOTTLE

- for distilled water
- plastic



Code	Number	Contents ccm	Pieces	Weight/g
0278000000000	278	1000	1	54

240S12

BATTERY SERVICE TOOL KIT

- 12-pcs.
- for battery maintenance and service
- box made from heavy gauge sheet steel, with handle
- black laquered



Code	Number	Contents	Pieces	Weight/g
0240000000000	240S12	Double Open Ended Spanner, ELORA-100-10x13 mm Waterpump Plier, ELORA-130MB-240 Terminal Puller, ELORA-174-50 Terminal brush, ELORA-252 Battery Testing unit, ELORA-270 Battery acid tester, ELORA-277 2 Battery plastic bottles, ELORA-278 Cable knife, ELORA-281 Battery acid filler, ELORA-287 Screwdriver, ELORA-539-IS 150 Combination Plier, ELORA-495BI-205	1	4700

174-50

BATTERY TERMINAL PULLER

- for pulling off battery terminals, ball bearings, gear-wheels, etc.
- 2 arms
- 10 mm wrench size
- zinc-plated, spindle gunmetal-finish
- high grade tool steel

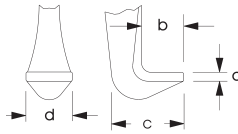

Code	Number	Span Width mm	a mm	b mm	c mm	d mm	Span depth mm	Pieces	Weight/g
0174000506100	174-50	10-60	1	5	12	8	40	1	160

174-80/2

BATTERY TERMINAL PULLER

- for pulling off battery terminals, ball bearings, gear-wheels, etc.
- 2 arms
- 12 mm wrench size
- zinc-plated, spindle gunmetal-finish
- high grade tool steel

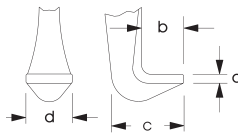

Code	Number	Span Width mm	a mm	b mm	c mm	d mm	Span depth mm	Pieces	Weight/g
0174008026100	174-80/2	10-90	1,8	10	20	12	84	1	350

174-80/3

BATTERY TERMINAL PULLER

- for pulling off battery terminals, ball bearings, gear-wheels, etc.
- 3 arms
- 12 mm wrench size 12 mm
- zinc-plated, spindle gunmetal-finish
- high grade tool steel

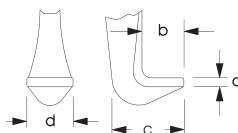

Code	Number	Span Width mm	a mm	b mm	c mm	d mm	Span depth mm	Pieces	Weight/g
0174008036100	174-80/3	10-90	1,8	10	20	12	84	1	450

168-...

JOINT BOLT PULLER

- for gentle removing of ball joint pivots on steering tie rods and stabilizers
- zinc-plated, gunmetal-finish
- high grade tool steel

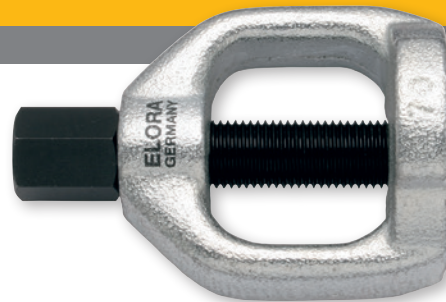

Code	Number	Jaw opening mm	Height mm	Spread mm	mm	Pieces	Weight/g
0168000186100	168-18	18	40	40	17	1	300
0168000236100	168-23	25	50	50	17	1	597
0168000296100	168-29	29	60	60	19	1	920
0168000406100	168-40	40	80	80	22	1	2100
0168000466100	168-46	45	100	90	27	1	2800

169-...

JOINT BOLT PULLER

- for gentle removing of ball joint pivots on steering tie rods and stabilizers
- zinc-plated, gunmetal-finish
- high grade tool steel



Code	Number	Jaw opening mm	max. Span Width mm	⌀ mm	Pieces	Weight/g
0169000506100	169-50	24	50	17	1	1400
0169000806100	169-80	24	80	17	1	1700
0169000906100	169-90	36	90	22	1	4450
0169001156100	169-115	45	115	27	1	6300

328

JOINT BOLT PULLER

- for gentle removing of ball joint pivots on steering tie rods and stabilizers
- zinc-plated
- high grade tool steel



Code	Number	Span Width mm	l/mm	⌀ mm	Pieces	Weight/g
0328000506100	328	50	100	19	1	779

323-...

JOINT BOLT PULLER

- for gentle removing of ball joint pivots on steering tie rods and stabilizers
- suitable for difficult to reach areas
- zinc-plated, gunmetal-finish
- high grade tool steel

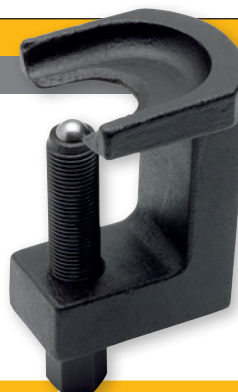

Code	Number	Jaw opening mm	Span Width mm	⌀ mm	Pieces	Weight/g
0323000236100	323-23	23	55	17	1	839
0323000286100	323-28	28	55	17	1	843
0323000346100	323-34	34	63	19	1	982

175-...

HUB PULLER

- for vehicle hubs with a bolt circle diameter up to 225 mm
- pulling legs movable and replaceable
- nickel-plated, spindle gunmetal-finish
- Chrome-Vanadium 31CrV3 / 1.2208



Code	Number	Legs	Bolt Circle mm	Pieces	Weight/g
0175000033000	175-3	3	to 225	1	3700
0175000053000	175-5	5	to 225	1	4700

314S3

V-BELT PULLEY PULLER SET

- **15 pcs. for following applications:**
- Variant 1 for V-belt pulleys with threaded holes
- 1 short beam for V-belt pulleys Ø 43-120 mm
- 1 long beam for V-belt pulley Ø 95-210 mm
- 3 exchangeable push-pieces to use as spindle extension
- Variant 2 for V-belt pulley without threaded holes
- 1 short beam for V-belt pulleys Ø 24-100 mm
- 1 long beam for V-belt pulley Ø 85-195 mm
- Hooks for narrow spaces for clamping depth up to 68 mm, respectively extension up to 88 mm
- Variant 3 with 2 hooks to reach the rills of the V-belt pulley
- 1 short beam for V-belt pulleys Ø 80-140 mm
- 1 long beam for V-belt pulley Ø 135-235 mm
- in a black plastic case 260 x 210 x 62 mm
- high grade tool steel, zinc-plated
- spindle and push-pieces gunmetal-finish



Code	Number	max. Span Width mm	max. depth mm	Pieces	Weight/g
0314500306100	314S3	195	88	1	2740

172-...

PULLER

- 2 legs, heavy-duty pattern, silver-coloured, puller legs to be used on both sides: one side with wide, the other side with narrow hooks
- zinc-plated, spindles gunmetal-finish
- high grade tool steel

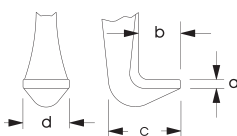

Code	Number	Span Width mm	a mm	b mm	c mm	d mm	Opening mm	mm	Pieces	Weight/g
0172001506100	172-150	20-150	2	9	21	12	85	17	1	900
0172002006100	172-200	40-220	4	11	25	21	130	19	1	2100

173-...

STANDARD PULLER

- heavy forged pattern
- 2 arms
- by turning the puller hooks usable as external and internal puller
- zinc-plated, spindle gunmetal-finish
- high grade tool steel

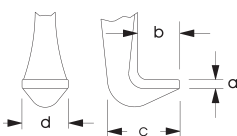

(further sizes on request)



Code	Number	External Tension mm	Internal Tension mm	Span depth mm	a mm	b mm	c mm	d mm	mm	Pieces	Weight/g
0173000806100	173-80	20-90	70-130	100	3	13	25	20	17	1	1100
0173001306100	173-130	25-130	80-180	100	3	13	25	20	17	1	1200
0173001606100	173-160	50-160	105-220	150	4	16	35	25	22	1	2860
0173002006100	173-200	60-200	120-270	150	4	16	35	25	22	1	3420
0173002506100	173-250	80-250	160-330	200	5	25	54	35	27	1	7480
0173003506100	173-350	80-350	160-420	200	5	25	54	35	27	1	8600
0173005206100	173-520	110-520	195-600	200	5	25	54	35	27	1	13000
0173006406100	173-640	140-640	225-715	225	5	25	54	35	27	1	23160

173K-...

STANDARD PULLER

- heavy-duty, forged pattern
- 2 arms, with very narrow forged pulling hooks
- especially suitable for difficult to reach areas
- zinc-plated, spindle and pulling hook end gunmetal-finish
- high grade tool steel

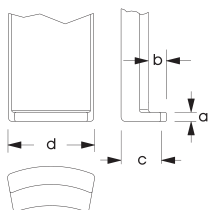

(further sizes on request)



Code	Number	Span Width mm	Span Depth mm	a mm	b mm	c mm	d mm	mm	Pieces	Weight/g
0173020806100	173K-80	20-90	100	3,6	8	14	28	17	1	1000
0173021306100	173K-130	25-130	100	3,6	8	14	28	17	1	1200
0173021606100	173K-160	50-160	150	5	7,5	15	40	22	1	2850
0173022006100	173K-200	60-200	150	5	7,5	15	40	22	1	3400

173S

PULLER SET

- 2 arms with 3 pairs of hooks in different lengths
- especially suitable for difficult to reach areas
- zinc-plated, spindle and pulling hook end gunmetal-finish
- high grade tool steel

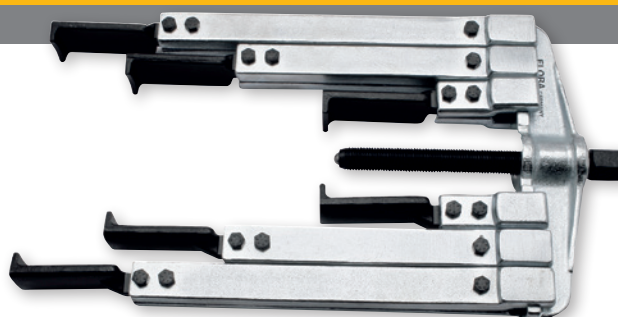

Code	Number	Contents	Pieces	Weight/g
0173500006100	173S	1 Bridge, Span width 25-130 mm 1 Spindle, Thread length 130 mm 2 Puller hooks, opening 100 mm 2 Puller hooks, opening 200 mm 2 Puller hooks, opening 250 mm	1	3300

176-...

PULLER

- for pulling off ball bearings, gear-wheels, discs, etc.
- heavy-duty, forged pattern
- 2 arms
- zinc-plated, spindle gunmetal-finish
- high grade tool steel

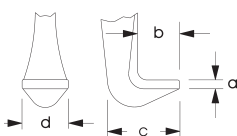

Code	Number	Span Width mm	Span Depth mm	a mm	b mm	c mm	d mm	mm	Pieces	Weight/g
0176001006100	176-100	18-100	85	2	10	20	14	12	1	450
0176002006100	176-200	20-200	150	3	14	25	18	17	1	980
0176002506100	176-250	35-250	220	4	20	36	25	19	1	2450
0176003006100	176-300	50-300	250	5	25	48	30	22	1	5300
0176003506100	176-350	50-350	350	5	25	48	30	22	1	6300
0176004006100	176-400	50-400	400	5	25	48	30	22	1	6700
0176004506100	176-450	50-450	450	5	25	48	30	22	1	7200
0176005006100	176-500	50-500	500	5	25	48	30	22	1	7000

317-...

STANDARD PULLER

- for pulling off ball bearings, gear-wheels, discs, etc.
- heavy-duty, forged pattern
- 2 arms
- by turning the puller hooks usable as external and internal puller
- zinc-plated, spindle gunmetal-finish
- high grade tool steel

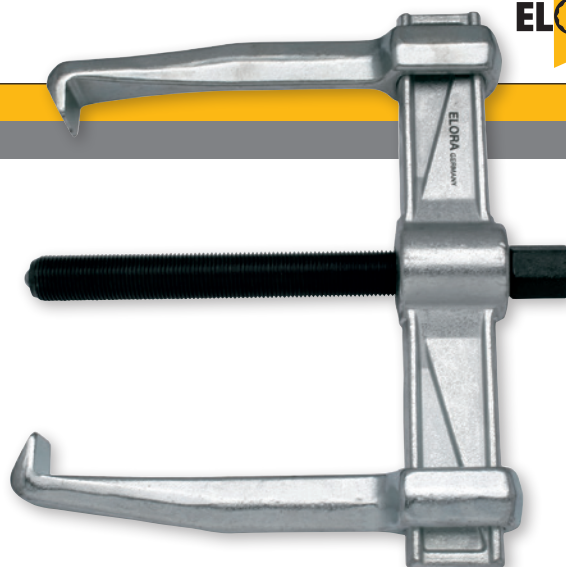
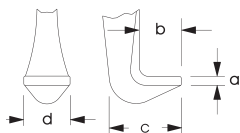

Code	Number	Extrenal Tension mm	Interal Tension mm	Span Depth mm	a mm	b mm	c mm	d mm	mm	Pieces	Weight/g
0317000806100	317- 80	15-80	70-130	100	3	12	22	22	17	1	922
0317001206100	317-120	15-120	80-170	100	3	12	22	22	17	1	1052
0317001606100	317-160	20-160	110-210	150	4	18	30	29	22	1	2700
0317002006100	317-200	20-200	120-250	150	4	18	30	29	22	1	2920
0317002506100	317-250	40-250	170-300	200	6,5	23	43	38	27	1	6760
0317003506100	317-350	40-350	190-400	200	6,5	23	43	38	27	1	7760

320-...

PULLER

- for pulling off ball bearings, gear-wheels, v-belt pullers etc.
- 3 arms, with double-sided useable hook ends
- zinc-plated, spindle gunmetal-finish
- high grade tool steel

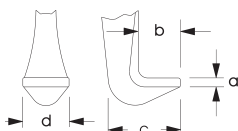

Code	Number	Span Width mm	Span Depth mm	a mm	b mm	c mm	d mm	mm	Pieces	Weight/g
0320001506100	320-150	20-150	85	2	9	21	12	17	1	1184
0320002006100	320-200	40-220	130	4	11	25	21	19	1	2800

322-...

PULLER

- for pulling off ball bearings at difficult to reach areas
- with particularly narrow hooks
- automatical fitting of the hooks due to scissor effect
- zinc-plated, spindle gunmetal-finish
- high grade tool steel

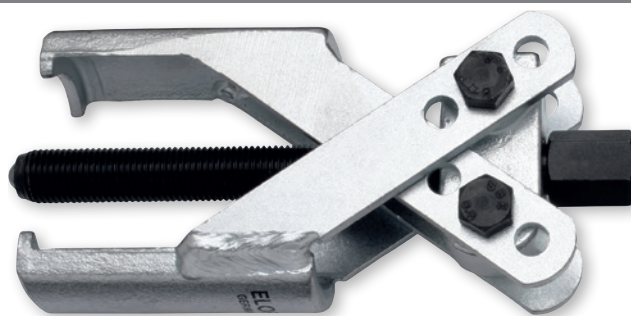
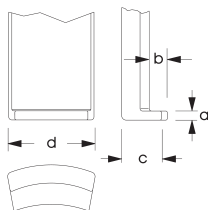

Code	Number	Span Width mm	Span Depth mm	a mm	b mm	c mm	d mm	mm	Pieces	Weight/g
0322001006100	322-100	6-100	70-85	2,5	4,5	8,5	23	12	1	430
0322001406100	322-140	10-140	85-120	3,5	5	10	31	17	1	1008

325, 326

SEPARATORS AND TAPERED BLADES

- for pulling off ball and roller bearings and close-fitting components
- zinc-plated, spindles gunmetal-finish
- high grade tool steel



Code	Number	Ø mm	for separator	mm	mm	Pieces	Weight/g
0325000606100	325-60	5-60	326-45	17	M12	1	390
0325000756100	325-75	12-75	326-45	19	M12	1	650
0325001156100	325-115	22-115	326-80	24	M16	1	1753
0325001506100	325-150	25-155	326-100	30	M20 x 1,5	1	3900
0326000456100	326-45	45-140	-	17	M12	1	1027
0326000806100	326-80	55-205	-	22	M16	1	2800
0326001006100	326-100	90-260	-	22	M20 x 1,5	1	5000

177-...

PULLER

- for pulling off ball bearings, gear-wheels, v-belt pulley etc.
- heavy-duty, forged pattern
- 3 arms
- zinc-plated, spindle gunmetal-finish
- high grade tool steel

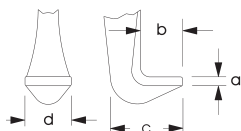

Code	Number	Span Width mm	Span Depth mm	a mm	b mm	c mm	d mm	mm	Pieces	Weight/g
0177001006100	177-100	18-100	85	2	8	20	17	12	1	500
0177002006100	177-200	20-200	150	3	12	25	18	17	1	1700
0177002506100	177-250	35-250	220	3	18	32	18	19	1	3900
0177003006100	177-300	50-300	250	5	22	50	30	22	1	7300
0177003506100	177-350	50-350	350	5	22	50	30	22	1	8300
0177004006100	177-400	50-400	400	5	22	50	30	22	1	8800
0177004506100	177-450	50-450	450	5	22	50	30	22	1	9400
0177005006100	177-500	50-500	500	5	22	50	30	22	1	10000

327-...

UNIVERSAL PULLER

- heavy-duty, forged pattern
- 3 arms
- by turning the puller hooks usable as external and internal puller
- zinc-plated, spindle gunmetal-finish
- high grade tool steel

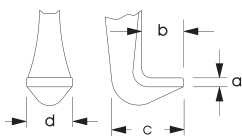

Code	Number	Span Width mm	Span Depth mm	a mm	b mm	c mm	d mm	mm	Pieces	Weight/g
0327000806100	327-80	20-90	100	3	13	25	20	17	1	1300
0327001306100	327-130	25-130	100	3	13	25	20	17	1	1500
0327001606100	327-160	50-160	150	4	16	35	25	22	1	3980
0327002006100	327-200	60-200	150	4	16	35	25	22	1	3900

327K-...

UNIVERSAL THREE LEG PULLERS WITH HOOKS

- heavy duty, forged pattern
- 3 arms with very narrow forged hooks
- by turning the puller hooks usable as external and internal puller
- zinc-plated, spindle and hook ends gunmetal-finish
- high grade tool steel

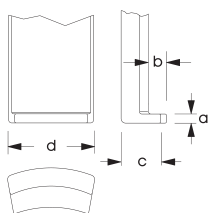

Code	Number	Span Width mm	Span Depth mm	a mm	b mm	c mm	d mm	mm	Pieces	Weight/g
0327020806100	327K-80	20-90	100	3,6	8	14	28	17	1	1262
0327021306100	327K-130	25-130	100	3,6	8	14	28	17	1	1446
0327021606100	327K-160	50-160	150	5	7,5	15	40	22	1	3900
0327022006100	327K-200	60-200	150	5	7,5	15	40	22	1	4150

372-...

INTERNAL EXTRACTOR

- for extracting close-fitting ball-bearings over the inner bearing ring
- to use with counter support ELORA-No. 373
- gunmetal-finish
- high grade tool steel



Code	Number	for Ø mm	Pieces	Weight/g
0372000056100	372-5	5-7	1	49
0372000076100	372-7	7-9	1	49
0372000106100	372-10	10-13	1	53
0372000146100	372-14	14-19	1	89
0372000206100	372-20	20-25	1	109
0372000256100	372-25	25-30	1	118
0372000306100	372-30	30-37	1	275
0372000386100	372-38	38-45	1	293
0372000406100	372-40	40-75	1	777
0372000716100	372-70	70-115	1	1372

373-...

COUNTER SUPPORT

- counter support for internal extractor ELORA-No. 372
- zinc-plated, spindle gunmetal-finish
- high grade tool steel



Code	Number	for extractor	mm	Pieces	Weight/g
0373000056100	373-5	372-5 until 372-38	12	1	649
0373000356100	373-35	372-40	19	1	1586
0373000706100	373-70	372-40 and 372-70	19	1	3380

372S9

INTERNAL EXTRACTOR SET

- 9 pcs.
- for extracting ball-bearings, ball-bearingrings and bushinger with a bore diameter of Ø 10–75 mm
- high grade tool steel
- in a black metal box 400 x 310 x 70 mm with a plastic insert



Code	Number	Contents	Pieces	Weight/g
0372500906100	372S9	372-10, 372-14, 372-20, 372-25, 372-30, 372-38, 372-40, 373- 5, 373-35	1	6750

372S13

PULLER SET

- 13 pcs.
- 3 Universal pullers for outside Ø 10-160 mm
- 7 internal pullers for bores Ø 10-75 mm
- 2 support braces
- 1 slide hammer
- high grade tool steel



Code	Number	Contents	Pieces	Weight/g
0372501306100	372S13	174-50 173-80, 173-160, 372-10, 372-14, 372-20, 372-25, 372-30, 372-38, 372-40, 373-5, 373-35, 1 slide hammer	1	15380

324S15

WINDSCREEN WIPER ARM PULLER SET

- 15 pcs.
- for removing screen wiper arms
- heavy-duty, forged pattern
- zinc-plated, spindle gunmetal-finish
- high grade tool steel
- in black plastic box 260 x 210 x 68 mm with a plastic foam insert



Code	Number	Contents	Width mm	Depth mm	Height mm	Pieces	Weight/g
0324501506100	324S-15	1 Bridge with spindle 1 puller with hooks 2 special hooks 1 spindle support 1 hollow push piece for wiper with water jet in the centre of the hub 1 spindle extension 8 hooks	260	68	210	1	2250

325S-...

PULLER/SEPARATOR SET

- containing one puller, one separator and one set of drawbar extensions
- zinc-plated, spindle gunmetal-finish
- dimensions:
25S-60, 325S-80: 265 x 197 x 45 mm
325S-100: 380 x 285 x 60 mm
325S-150: 417 x 380 x 75 mm



Code	Number	Contents	Opening mm	Span Ø mm	Pieces	Weight/g
0325500606100	325S-60	Extension 1 piece each 325-60, 326-45	150	5-60	1	2400
0325500806100	325S-80	Extension 1 piece each 325-75, 326-45	150	12-75	1	2980
0325501006100	325S-100	Extension 1 piece each 325-115, 326-80	210	22-115	1	7480
0325501506100	325S-150	Extension 1 piece each 325-150, 326-100	315	25-155	1	12920

1300...
TOOL KIT

- 16 pcs.
- in strong black storage wallet



Code	Number	Contents	Pieces	Weight/g
1300500161000	1300M	Double Open-Ended Spanners 100M 8 × 9, 10 × 11, 12 × 13, 14 × 17, 19 × 22 mm Spark Plug Wrench 222-16 × 20,8 Four way wheel nut wrench 195-CV17 Waterpump plier 132-240 2K Combination plier 495-BI185 2K Engineers Screwdriver 545-IS100 2K Screwdriver for cross slot screws 547-PH2 Engineers hammer 1665-300 Flat cold chisel 260-150 Centre punch 265-12 Contact file 249 Spark plug cleaning brush 251	1	4200
1300510161000	1300A	Double Open-Ended Spanners 100A- 5/16 × 3/8, 7/16 × 1/2, 9/16 × 5/8, 11/16 × 3/4, 13/16 × 7/8 af Spark Plug Wrench 222-16 × 20,8 Four way wheel nut wrench 195-CV17 Waterpump plier 132-240 2K Combination Plier 495-BI185 2K Engineers Screwdriver 545-IS100 2K Screwdriver for cross slot screws 547-PH2 Engineers hammer 1665-300 Flat cold chisel 260-150 Centre punch 265-12 Contact file 249 Spark plug cleaning brush 251	1	3800





DIFFERENT TOOLS

Pipe- and Plumber's Tools _____	Page 474
Scrapers _____	Page 479
Files/Rasps _____	Page 481
Brushes _____	Page 486
Knives/Cutters _____	Page 488
Saws _____	Page 491
Twist Drills, Hand Taps, Thread Repair, Tools, Countersinks _____	Page 494
Screw Extractors, Nut Splitters _____	Page 498
Oiling and Lubricating _____	Page 500
Lamps/Inspection Tools, Gripper _____	Page 501



13 chapters with more than 8,000 products are included in our current catalog. This is the basis for our daily customer orders, which we carefully select and reliably ship throughout the world.

301-...

CHAIN PIPE CUTTER

- ▶ for cutting tubes from Ø 15 - 75 mm und 2,5 mm wall thickness
- ▶ easy adjustment during the cutting operation by large thumb screw
- ▶ Spare chain ELORA No. 301E
- ▶ ELORA-No. 524E is an extension and a replace chain at the same time
- ▶ quick release lever with return spring
- ▶ Tempered steel, cutting wheel made of high alloy special steel



Code	Number	for pipes Ø mm	l/mm	Pieces	Weight/g
0301002503000	301-250	15-75	250	1	805
0301003003000	301-300	15-90	330	1	930
0301400003000	301E		330	1	340

181

BASIN NUT WRENCH

- ▶ for loosening and tightening the nuts of water faucets on the bottom of the washing- or hand basin
- ▶ forged shank with swivel-handle and steel claw
- ▶ yellow powder coated, gunmetal finished claw and knob
- ▶ ELORA Chrome-Vandium 31CrV3 / 1.2208



Code	Number	l/mm	Pieces	Weight/g
0181000000000	181	240	1	558

139

SPUD WRENCH

- ▶ for the assembly of valve nipples in heating units for 3/8", 1/2", 3/4", 1" and 4 intermediate steps
- ▶ with 1/2" square drive, chrome plated
- ▶ high grade tool steel

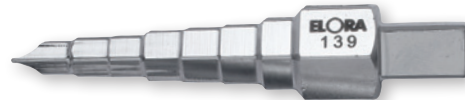

Code	Number	Pieces	Weight/g
0139000001000	139	1	152

65-...

TUBING CUTTER

- ▶ for thick-walled metal tubes
- ▶ with a cutting wheel and two guide rollers
- ▶ 65-2 body steel forged / 65-4 spheroidal graphite iron
- ▶ with spring loading system and ICS-wheel quick-change system
- ▶ Cutting wheel made of high alloy special steel



Code	Number	l/mm	for pipes Ø	Pieces	Weight/g
0065200026000	65-2	390	10-60 mm / 1/8-2"	1	2320
0065200046000	65-4	560	60-114 mm / 1.1/4-4"	1	7460
0065200126000	65S-2		spare cutting wheel for ELORA-No. 65-2	1	27
0065200146000	65S-4		spare cutting wheel for ELORA-No. 65-4	1	66
0065200326000	65-B2		spare bolt for ELORA-No.65-2	1	19
0065200346000	65-B4		spare bolt for ELORA-No.65-4	1	28

179-16

PIPE CUTTER

- for thin-walled metal tubes
- with a cutting wheel and two guide rollers
- with steel bearing spindle and ICS-wheel quick-change system
- yellow powder coating
- made of zinc die-cast



Code	Number	l/mm	for pipe Ø	Pieces	Weight/g
0179000166100	179-16	55	3-16 mm / 1/8-5/8"	1	114
0179001166100	179S-16	spare cutting wheel		1	6
0179002166100	179B-16	spare bolt		1	3

180-35

PIPE CUTTER 3-36 MM MADE OF MAGNESIUM DIE CAST

- for thin-walled metal tubes
- with 4 guiding rolls + ICS-wheel quick-change system
- with integrated burr remover with NOGA wheel
- with steel bearing spindle
- Spare wheel in rotary knob cap



Code	Number	l/mm	for pipe Ø	Pieces	Weight/g
0180000356100	180-35	160	3-36 mm - 1/8-1.3/8"	1	380
0180001356100	180-S35	spare cutting wheel		1	5
0180002356100	180-B35	spare bolt		1	3

180-76

PIPE CUTTER 6-76 MM MADE OF DIE CAST ALUMINIUM

- with built-in wheel ELORA-No. 180-S76B 30 x 6,2 mm for plastic and composite tubes
- Spare wheel in rotary knob cap ELORA-No. 180-S76A for thin-walled metal tubes 19 x 6,2 mm
- with 4 guiding rolls + ICS-wheel quick-change system
- Spare wheel in rotary knob cap
- with rapid feed



Code	Number	l/mm	for pipe Ø	Pieces	Weight/g
0180000766100	180-76	250	6-76 mm / 1/4-3"	1	970
0180001766100	180-S76A	spare cutting wheel for thin-walled metal tubes		1	9
0180001766101	180-S76B	spare cutting wheel for plastic and composite tubes		1	6
0180002766100	180-B76	spare bolt		1	3

181-ST...

PIPE CUTTER FOR THIN-WALLED METAL TUBES

- 181-ST1 - especially suitable for V2A tubes
- with 2 needle bearing guide rollers made of stainless steel
- with needle bearing cutting wheel for 2A pipes including spare wheel in the turning knob cap
- with steel bearing spindle and ICS wheel quick-change system
- ergonomic rotary knob with integrated spare cutting wheel
- made of die-cast zinc
- 181-ST2 - as above, however with 4 needle guide rollers made of stainless steel
- with removable tube deburrer + NOGA blade
- made of magnesium die-cast
- 181-ST3 - as above, however with 4 needle guide rollers made of stainless steel
- with removable tube deburrer + NOGA blade
- made of aluminium die-cast



Code	Number	l/mm	for pipe Ø	Pieces	Weight/g
0181000017000	181-ST1	75	3-30 mm / 1/8-1.1/8"	1	235
0181000027000	181-ST2	160	3-35 mm / 1/8-1.3/8"	1	376
0181000037000	181-ST3	250	6-76 mm / 1/4-3"	1	983
0181000017100	181-ST S1/S2	spare cutting wheel for 181-ST1/ST2		1	5
0181000037100	181-ST S3	spare cutting wheel for 181-ST3		1	6
0181000117100	181-ST B1/B2/B3	spare bolt for 181-ST 1/2/3		1	3

182-26

PLASTIC TUBE SNIP

- ▶ for plastic- and composite tubes with 1 stainless steel wheel PTFE coated
- ▶ suitable for PE-, PP-, PVC-, PB- and VPE tubes and hoses
- ▶ for clean, right-angled cuts
- ▶ made of magnesium die-cast



Code	Number	l/mm	for pipe Ø	Pieces	Weight/g
0182000260000	182-26	200	0-26 mm / 0-1"	1	278
0182400260000	182-E 26	spare blade		1	44
0182000006100	182-B	spare bolt		1	4

182-42

PLASTIC PIPE AND COMPOSITE PIPE CUTTING SCISSORS

- ▶ with 1 stainless steel blade, PTFE coated
- ▶ suitable for PE-, PP-, PVC-, PVDF-, PB- and PU pipes and hoses
- ▶ for clean, right-angled cuts
- ▶ with ratchet feed
- ▶ made of magnesium die-cast



Code	Number	l/mm	for pipe Ø	Pieces	Weight/g
0182000420000	182-42	200	0-42 mm / 0-1.5/8"	1	516
0182400420000	182-E 42	spare blade		1	84
0182000006100	182-B	spare bolt		1	4

182-63

PLASTIC PIPE AND COMPOSITE PIPE CUTTING SCISSORS

- ▶ for tubes up to 63 mm / 2. For tubes with 50 mm diameter or smaller with 1 stainless steel blade PTFE coated
- ▶ for plastic pipe and composite pipe cutting scissors with in 2 positions adjustable tube approaching system
- ▶ suitable for PE-, PP-, PVC-, PVDF-, PB- and VPE- pipes and hoses
- ▶ for clean, right-angled cuts
- ▶ with ratchet feed
- ▶ made of magnesium die cast



Code	Number	l/mm	for pipe Ø	Pieces	Weight/g
0182000630000	182-63	280	0-63 mm / 0-2.1/2"	1	708
0182400630000	182-E 63	spare blade		1	150
0182000006100	182-B	spare bolt		1	4

63-1

DEBURRING-BIT

- ▶ for effortless deburring of holes, slots and edges on metals and plastics
- ▶ special-bit (blade B12)
- ▶ hexagon drive acc. To DIN 3126 C 6,3, ISO 1173
- ▶ suitable for all 1/4"-drive bit holders

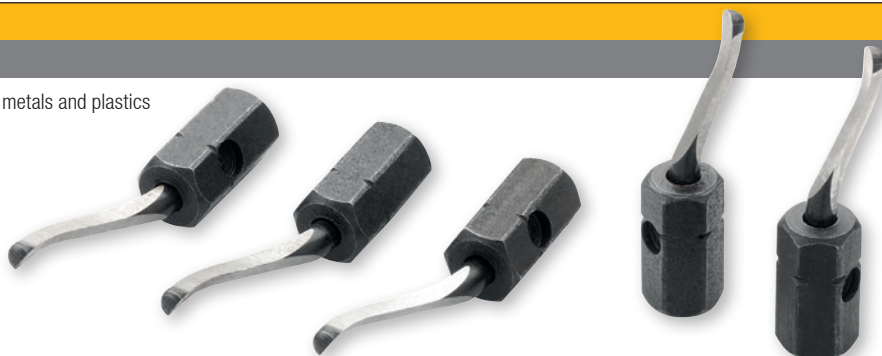

Code	Number	l/mm	Pieces	Weight/g
0063000011000	63-1	25	12	20

64

DEBURRING OR PIPE CUTTER

- ▶ for inner and outer deburring of copper-, brass-, aluminium- or plastic tubes



Code	Number	l/mm	for pipe Ø	Pieces	Weight/g
0064000007000	64	48	3-40 mm / 1/8-1.1/2"	1	55

241EK

FLARING TOOL

- ▶ for beading of copper and light alloy tubes
- ▶ flaring cone 90° hardened, corresponds to 45° at the tube
- ▶ body made of zinc die-cast
- ▶ to use with clamping jaws ELORA No. 241EB-...



Code	Number	Pieces	Weight/g
0241000000000	241EK	1	660

241EB-...

FLARING TOOL-CLAMPING JAWS

- ▶ to use with flaring tool ELORA-No. 241EK
- ▶ jaws made of steel, smooth inside, phosphated



Code	Number	for Flaring tool ELORA-No.	for pipes up to Ø mm	Pieces	Weight/g
0241010016000	241EB-1	241-1	4-14	1	630
0241010096000	241EB-9	241-9	15-19	1	695

241-...

FLARING TOOL WITH CLAMPING JAWS

- ▶ for beading of copper and light alloy tubes
- ▶ flaring cone 90° hardened, corresponds to 45° at the tube
- ▶ body made of zinc die-cast
- ▶ jaws made of steel, smooth inside, phosphated



Code	Number	for tubes outside Ø mm	Pieces	Weight/g
0241000016000	241-1	4, 4,75, 6, 8, 10, 12, 14	1	1350
0241000006000	241D	Pressure part for flaring jaws 180°	1	20

241SB-...

CUTTING AND FLARING SET

- 3 pcs.
- for beading of copper and light alloy tubes
- flaring cone 90 ° hardened, corresponds to 45 ° at the tube
- body made of zinc die-cast
- jaws made of steel, smooth inside, phosphated
- pipe cutter with a cutting wheel and two guide rollers
- ergonomic rotary knob with integrated trim knife
- painted, gunmetal finished spindle
- cutting wheel made of high alloy special steel



Code	Number	Contents	Pieces	Weight/g
0241020016000	241SB-1	Flaring tool with jaw 241-1 for Tubes outside \varnothing 4, 4,75, 6, 8, 10, 12, 14 mm Tubing cutter 179-35	1	2600
0241020096000	241SB-9	Flaring tool with jaw 241-9 for Tubes outside \varnothing 15, 16, 17, 18, 19 mm Tubing cutter 179-35	1	2590

406-...

TUBE BENDING PLIER

- for bends up to 90°
- for thin-walled bendable steel pipes or copper pipes
- with plastic handle protectors

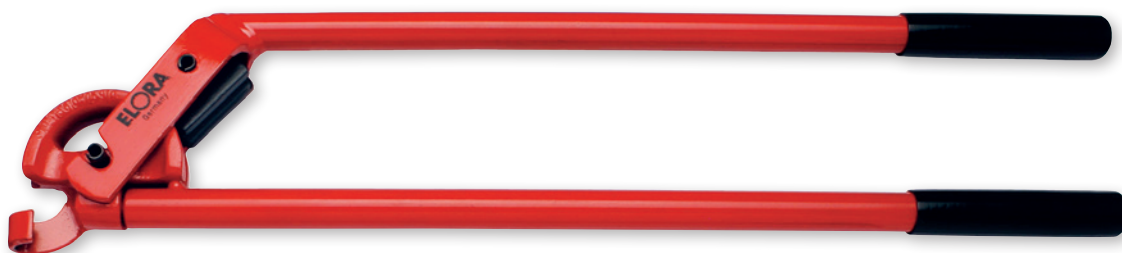

Code	Number	l/mm	for pipes up to \varnothing mm	Pieces	Weight/g
0406000120000	406-12	515	12	1	1300
0406000150000	406-15	665	15	1	2400
0406000160000	406-16	665	16	1	2400
0406000220000	406-22	950	22	1	5600

407

TUBE BENDING PLIER

- for dimensions from 4,75 – 10 mm (3/16" – 3/8") \varnothing up to 90°
- for soft copper pipes EN 1057, Ne-metal pipes as well as thin-walled precision steel pipes and brake lines
- with 2 turnable bending dies 3/16", 1/4" and 5/16", 3/8"



Code	Number	l/mm	for pipes up to \varnothing mm	Pieces	Weight/g
0407000001000	407	260	4,75-10	1	580

408

STEP ARBOR

- for expanding copper tubes
- black, made of special steel



Code	Number	l/mm	Expanding steps Ø mm	Pieces	Weight/g
0408000000000	408	290	10/12, 13/15, 16/18, 20/22, 25/28	1	960

272-...

THREE SQUARE HOLLOW GROUND SCRAPER

- black-painted version with wooden handle
- ground work surfaces
- heat-treated steel



Code	Number	l/mm	Blade Length Inch	Pieces	Weight/g
0272001506000	272-150	150	6	6	92
0272002006000	272-200	200	8	6	145
0272002506000	272-250	250	10	6	175
0272003006000	272-300	300	12	6	230

273-...

BEARING SCRAPER OR HOLLOW GROUND SCRAPER

- black-painted version with wooden handle
- ground work surfaces
- heat-treated steel



Code	Number	l/mm	Blade Length Inch	Pieces	Weight/g
0273001006000	273-100	100	4	6	64
0273001506000	273-150	150	6	6	94
0273002006000	273-200	200	8	6	130
0273002506000	273-250	250	10	6	200
0273003006000	273-300	300	12	6	280

274-...

THREE SQUARE HOLLOW SCRAPER

- black-painted version with wooden handle
- ground work surfaces
- heat treated steel
- DIN 8350, shape C



Code	Number	mm	Blade Length Inch	Pieces	Weight/g
0274000806000	274-80	80	3	6	35
0274001006000	274-100	100	4	6	68
0274001256000	274-125	125	5	6	74
0274001506000	274-150	150	6	6	104
0274001756000	274-175	175	7	6	114
0274002006000	274-200	200	8	6	140
0274002506000	274-250	250	10	6	195
0274003006000	274-300	300	12	6	220

276-...

HOLLOW SCRAPER

- black-painted version with wooden handle
- ground work surfaces
- heat treated steel
- DIN 8350, shape A



Code	Number	mm	Blade Length Inch	Pieces	Weight/g
0276002006000	276-200	200	8	6	210
0276002506000	276-250	250	10	6	265

290...

SEAL FLAT SCRAPER

- ground work surfaces
- non-slip QUATROLIT-2C-handle
- heat treated steel





Code	Number	Productinformation	mm	l/mm	Pieces	Weight/g
0290000000000	290	straight	155	260	6	115
0290000800000	290-80	straight	80	180	6	65
0290010800000	290-80G	cranked	60	160	6	65

207-...

THREE SQUARE FILE

- with tang and cut on three sides
- tapered
- 2-component handle
- according to DIN 7261, shape C







Code	Number	Cut	 l/mm	Total Length mm	Blade Length Inch	Pieces 	Weight/g 
0207211501000	207-1x150	Bastard, Cut 1	150	240	6	6	82
0207212001000	207-1x200	Bastard, Cut 1	200	310	8	6	184
0207212501000	207-1x250	Bastard, Cut 1	250	360	10	6	345
0207221501000	207-2x150	Second, Cut 2	150	240	6	6	82
0207222001000	207-2x200	Second, Cut 2	200	310	8	6	184
0207222501000	207-2x250	Second, Cut 2	250	360	10	6	345
0207231501000	207-3x150	Smooth, Cut 3	150	240	6	6	82
0207232001000	207-3x200	Smooth, Cut 3	200	310	8	6	184
0207232501000	207-3x250	Smooth, Cut 3	250	360	10	6	345

208-...

ENGINEERS FILE

- with tang and cut on four sides
- tapered
- 2-component handle
- according to DIN 7261, shape D







Code	Number	Cut	 l/mm	l/mm 	Blade Length Inch	Pieces 	Weight/g 
0208211501000	208-1x150	Bastard, Cut 1	150	240	6	6	52
0208212001000	208-1x200	Bastard, Cut 1	200	310	8	6	122
0208212501000	208-1x250	Bastard, Cut 1	250	360	10	6	195
0208221501000	208-2x150	Second, Cut 2	150	240	6	6	52
0208222001000	208-2x200	Second, Cut 2	200	310	8	6	122
0208222501000	208-2x250	Second, Cut 2	250	360	10	6	195
0208231501000	208-3x150	Smooth, Cut 3	150	240	6	6	52
0208232001000	208-3x200	Smooth, Cut 3	200	310	8	6	122
0208232501000	208-3x250	Smooth, Cut 3	250	360	10	6	195

246-...

RECTANGULAR FILE

- cut on three sides
- tanged
- 2-component handle
- according to DIN 7261, shape A







Code	Number	Cut	 l/mm	l/mm 	Blade Length Inch	Pieces 	Weight/g 
0246211500000	246-1x150	Bastard, Cut 1	150	240	6	6	87
0246212000000	246-1x200	Bastard, Cut 1	200	310	8	6	201
0246212500000	246-1x250	Bastard, Cut 1	250	360	10	6	311
0246213000000	246-1x300	Bastard, Cut 1	300	430	12	6	452
0246221500000	246-2x150	Second, Cut 2	150	240	6	6	87
0246222000000	246-2x200	Second, Cut 2	200	310	8	6	201
0246222500000	246-2x250	Second, Cut 2	250	360	10	6	311
0246223000000	246-2x300	Second, Cut 2	300	430	12	6	452
0246231500000	246-3x150	Smooth, Cut 3	150	240	6	6	87
0246232000000	246-3x200	Smooth, Cut 3	200	310	8	6	201
0246232500000	246-3x250	Smooth, Cut 3	250	360	10	6	311
0246233000000	246-3x300	Smooth, Cut 3	300	430	12	6	452

247-...

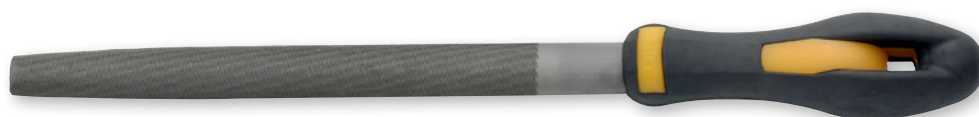
HALF ROUND FILE

- cut on two sides
- tanged
- 2-component handle
- according to DIN 7261, shape E





Code	Number	Cut	 /mm	l/mm	Blade Length Inch	Pieces 	Weight/g 
0247211500000	247-1x150	Bastard, Cut 1	150	240	6	6	81
0247212000000	247-1x200	Bastard, Cut 1	200	310	8	6	169
0247212500000	247-1x250	Bastard, Cut 1	250	360	10	6	279
0247213000000	247-1x300	Bastard, Cut 1	300	430	12	6	442
0247221500000	247-2x150	Second, Cut 2	150	240	6	6	81
0247222000000	247-2x200	Second, Cut 2	200	310	8	6	169
0247225000000	247-2x250	Second, Cut 2	250	360	10	6	279
0247230000000	247-2x300	Second, Cut 2	300	430	12	6	442
0247231500000	247-3x150	Smooth, Cut 3	150	240	6	6	81
0247232000000	247-3x200	Smooth, Cut 3	200	310	8	6	169
0247232500000	247-3x250	Smooth, Cut 3	250	360	10	6	279
0247233000000	247-3x300	Smooth, Cut 3	300	430	12	6	442

248-...

ROUND FILE

- with circumferential cut
- tanged
- 2-component handle
- according to DIN 7261, shape F







Code	Number	Cut	 /mm	l/mm	Blade Length Inch	Pieces 	Weight/g 
0248211500000	248-1x150	Bastard, Cut 1	150	240	6	6	48
0248212000000	248-1x200	Bastard, Cut 1	200	310	8	6	102
0248212500000	248-1x250	Bastard, Cut 1	250	360	10	6	171
0248221500000	248-2x150	Second, Cut 2	150	240	6	6	48
0248222000000	248-2x200	Second, Cut 2	200	310	8	6	102
0248222500000	248-2x250	Second, Cut 2	250	360	10	6	171
0248231500000	248-3x150	Smooth, Cut 3	150	240	6	6	48
0248232000000	248-3x200	Smooth, Cut 3	200	310	8	6	102
0248232500000	248-3x250	Smooth, Cut 3	250	360	10	6	171

1344-...

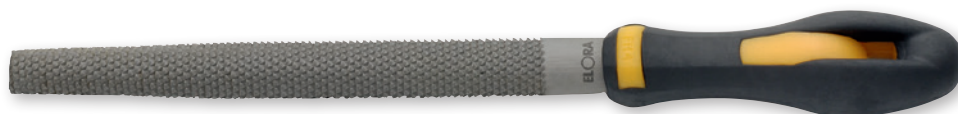
HALF ROUND RASP

- rasp cut on two sides
- tapered
- 2-component handle
- according to DIN 7263, shape C



Code	Number	Cut	 /mm	l/mm	Blade Length Inch	Pieces 	Weight/g 
1344212000000	1344-1x200	Bastard, Cut 1	200	310	8	6	172
1344212500000	1344-1x250	Bastard, Cut 1	250	360	10	6	281
1344222000000	1344-2x200	Second, Cut 2	200	310	8	6	172
1344222500000	1344-2x250	Second, Cut 2	250	360	10	6	281

1345-...

RECTANGULAR RASP

- Cut on 3 sides
- tapered
- 2-component handle
- according to DIN 7263, shape A

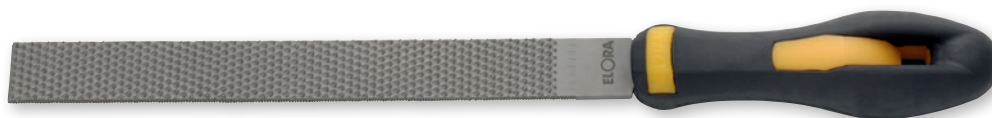

Code	Number	Cut	mm	l/mm	Blade Length Inch	Pieces	Weight/g
1345222000000	1345-2x200	Second, Cut 2	200	310	8	6	190
1345222500000	1345-2x250	Second, Cut 2	250	360	10	6	332

1346-...

ROUND RASP

- with circumferential rasp cut
- tapered towards the tip
- 2-component handle
- according to DIN 7263, shape E



Code	Number	Cut	mm	l/mm	Blade Length Inch	Pieces	Weight/g
1346222000000	1346-2x200	Second, Cut 2	200	310	8	6	114
1346222500000	1346-2x250	Second, Cut 2	250	360	10	6	253

255 K-...

FILE AND RASP HANDLE

- 2-component handles as replacement part for Elora-No. 207, 208, 246, 247, 248, 1344, 1345, 1346



Code	Number	for Blade Length mm	for Blade Length Inch	l/mm	Pieces	Weight/g
0255020907100	255K-90	150	6	90	6	22
0255021107100	255K-110	200	8	110	6	36
0255021107101	255K-110/1	200 + 250	8 + 10	110	6	36
0255021257100	255K-125	300	12	130	6	42
0255021257101	255K-125/1	300 + 350	12 + 14	130	6	42

209 S5K

MACHINIST'S FILE SET

- 5-pcs. smooth cut file set (cut 2) with 2-component handle
- in plastic pouch
- according to DIN 7261



Code	Number	Productinformation	Pieces	Weight/g
0209500000001	209 S5K	1 piece each 207-2 × 200 208-2 × 200 246-2 × 200 247-2 × 200 248-2 × 200	1	965

1347-S160

NEEDLE FILE SET

- 6-pcs. second cut file set (cut 2)
- in plastic pouch



Code	Number	Pieces 	Weight/g
1347501600000	1347-S160	6	65

254S-HK

KEY FILE SET WITH WOODEN HANDLE

- 6 pcs.
- in plastic pouch
- according to DIN 7283, shape A-F



Code	Number	l/mm 	Pieces 	Weight/g
0254000008000	254S-HK	100	6	115

254S-HB

KEY FILE SET WITH WOODEN HANDLE

- 6 pcs.
- in metal box
- according to DIN 7283, shape A-F



Code	Number	l/mm 	Pieces 	Weight/g
0254000018000	254S-HB	100	6	160

You will find contact files on page no. 441



You will find a contact file set on page no. 441



258...

THREAD RESTORING FILE

- for the repair of damaged internal and external threads
- nickel plated
- special steel
- for metric-, imperial- and SAE-threads



Code	Number	l/mm		Pieces	Weight/g
0258000015200	258 MM	230		6	130
0258000025200	258 AF	230		6	130
0258000035200	258 WW	230		6	130

Elora-Nr.	258 MM ----ISO----		258 AF ----WW (UNF, UNC)----		258 WW BSW/BSF
	pitch of thread mm	metric thread	turns up to 1"	Whitworth- pitch	turns up to 1"
	0,80	5	24	3/16 + 7/32	24
	1,00	6 + 7	20	1/4	20
	1,25	8 + 9	18	5/16	18
	1,50	10 + 11	16	3/8	16
	1,75	12	14	7/16	14
	2,00	14 + 16	13	1/2 + 9/16	12
	2,50	18, 20, 22	12	5/8 + 11/16	11
	3,00	24 + 27	11	3/4 + 13/16	10

You will find file holders for car body files and car body file blades on page no. 456



250FB**FILE BRUSH**

- working area 250 x 40 mm
- rugged wooden handle with wear-resistant steel wire spiked band



Code	Number	l/mm	l/Inch	Pieces	Weight/g
0250000000000	250FB	250	10	6	80

250-...**WIRE BRUSH**

- bristles made of smooth steel wire
- trim length 25 mm, V-shaped
- wooden handle with 2 hanging holes



Code	Number	Working Surface mm	l/mm	l/Inch	Pieces	Weight/g
0250000300000	250-3	3 rows, 145 / 4,0 Inch	295	12	6	50
0250000400000	250-4	4 rows, 145 / 4,0 Inch	295	12	6	66
0250000500000	250-5	5 rows, 145 / 4,0 Inch	295	12	6	68
0250000600000	250-6	6 rows, 145 / 4,0 Inch	295	12	6	70

250-ST...**WIRE BRUSH STAINLESS**

- bristles made of crimped stainless steel wire
- trim length 25 mm, V-shaped
- Wooden handle with 2 hanging holes



Code	Number	Working Surface mm	l/mm	l/Inch	Pieces	Weight/g
0250000301000	250-ST3	3rows, 145 / 4,0 Inch	295	12	6	50
0250000401000	250-ST4	4rows, 145 / 4,0 Inch	295	12	6	66
0250000501000	250-ST5	5rows, 145 / 4,0 Inch	295	12	6	68
0250000601000	250-ST6	6rows, 145 / 4,0 Inch	295	12	6	70

You will find a spark plug brush on page no. 449



You will find brushes for brake service on page no. 441



2865

CUP BRUSH

- ▶ internal thread M14 for mounting on angle grinders
- ▶ bristles made of corrugated steel wire \varnothing 0.3 mm
- ▶ max. speed 12500 rpm

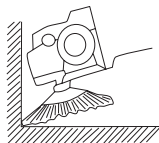

Code	Number	\varnothing mm	Pieces	Weight/g
2865000000000	2865	60	1	191

2850

CUP BRUSHES, TWISTED WIRE

- ▶ internal thread M14 for mounting on angle grinders
- ▶ bristles made of twisted steel wire \varnothing 0.5 mm
- ▶ max. speed 12500 rpm

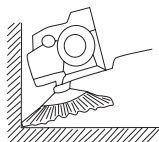

Code	Number	\varnothing mm	Pieces	Weight/g
2850000000000	2850	65	1	320

2855

KNOT WIRE WHEEL BRUSH

- ▶ arbor hole 22.2 mm for mounting on angle grinders
- ▶ bristles made of knotted steel wire \varnothing 0,5 mm
- ▶ max. speed 12500 rpm

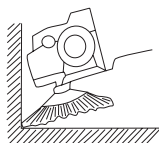

Code	Number	\varnothing mm	Pieces	Weight/g
2855000000000	2855	115	1	305

2860

KNOT CONE BRUSH

- ▶ internal thread M14 for mounting on angle grinders
- ▶ bristles made of hardened steel wire \varnothing 0,5 mm
- ▶ max. speed 12500 rpm

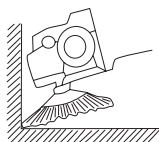

Code	Number	\varnothing mm	Pieces	Weight/g
2860000000000	2860	100	1	250

281-B

KNIFE / LEAD KNIFE

- riveted design with wooden handle
- straight blade



Code	Number	l/mm	l/mm	Pieces	Weight/g
0281000001000	281-B	65	180	6	50

281-T

SAFETY KNIFE

- fixed trapezoidal blade
- one blade ELORA-No. 281TK-52 included
- heavy duty design with black handle and blade magazine
- Handle made from die-cast aluminium
- Replacement blades see Elora No. 281TK-52 and 281HK-52



Code	Number	l/mm	Pieces	Weight/g
0281000101000	281-T	140	6	120

281-U

SAFETY KNIFE

- 3-position adjustable cutting depth
- trapezoidal blade fully retractable into the handle
- one blade ELORA-No. 281TK-52 included
- heavy duty design with black handle and blade magazine
- handle made from die-cast aluminium
- replacement blades see Elora No. 281TK-52 and 281HK-52



Code	Number	l/mm	Pieces	Weight/g
0281000201000	281-U	160	6	170

281-S

AUTOMATIC SAFETY KNIFE

- with automatic reset: Blade retracts when releasing the slider in the handle
- one blade ELORA-No. 281TK-52 included
- heavy duty design with black handle and blade magazine
- Handle made from die-cast aluminium
- Replacement blades see Elora No. 281TK-52 and 281HK-52



Code	Number	l/mm	Pieces	Weight/g
0281000301000	281-S	170	6	160

281-K1

SAFETY KNIFE WITH HOLSTER

- fixed trapezoidal blade
- one blade Elora no. 281TK-60 included
- heavy duty design with black handle and blade magazine
- handle made from die-cast aluminium with plastic insert
- holster made of plastic with belt clip
- replacement blade see ELORA-No. 281TK-60



Code	Number	l/mm	Pieces	Weight/g
0281000601000	281-K1	170	6	280

281-K2

SAFETY KNIFE WITH HOLSTER

- 3-position adjustable cutting depth
- trapezoidal blade fully retractable into the handle
- one blade ELORA-No. 281TK-60 included
- heavy duty design with black handle and blade magazine
- handle made from die-cast aluminium with plastic insert
- holster made of plastic with belt clip
- replacement blade see ELORA-No. 281TK-60



Code	Number	l/mm	Pieces	Weight/g
0281000701000	281-K2	190	6	325

281TK-..., 281-HK52

BLADES FOR SAFETY KNIFE

- for safety knife ELORA-No. 281-T,U,S, K1 und K2
- ice tempered blades in industrial quality

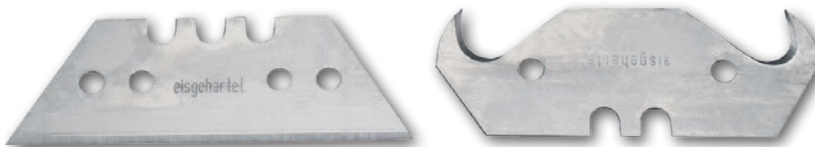

Code	Number	l/mm	Pieces	Weight/g
0281400521000	281-TK52	52	5	12
0281400601000	281-TK60	60	5	20
0281410521000	281-HK52	52	5	12

281-KA18, 281-PK

SAFETY CUTTER

- with safety lock and snap-off blade
- incl. 3 replacement blades ELORA-No. 281-PK
- heavy duty design with black handle and blade magazine
- Handle made from die-cast aluminium



Code	Number	Productinformation	l/mm	Pieces	Weight/g
0281000801000	281-KA18	Cutter	180	6	220
0281400401000	281-PK	10 spare blades	110	1	65

281-C, 281-CK

CUTTER

- Design with precision metal guide and 9 mm wide, ice tempered blade
- automatically arresting safety lock
- Plastic handle



Code	Number	Productinformation	l/mm	Pieces	Weight/g
0281000501000	281-C	Cutter	135	6	190
0281400501000	281-CK	10 spare blades	85	1	25

281-P, 281-PK

CUTTER

- Design with precision metal guide and 18 mm wider, ice tempered blade
- rear cap removable to snap off the used blade strips
- automatically arresting safety lock
- plastic handle



Code	Number	Productinformation	l/mm	Pieces	Weight/g
0281000401000	281-P	Cutter	160	6	85
0281400401000	281-PK	10 spare blades	110	1	65

You will find cable knives
on page no. 304



189**HACKSAW FRAME**

- ▶ adjustable, for hacksaw blades with 250 mm (10") or 300 mm (12") length
- ▶ including metal saw blade 300 mm (12")
- ▶ similar to DIN 6473, shape B



Code	Number	adjustable in	l/mm	l/Inch	Pieces	Weight/g
0189000000000	189	200/300	420	11	1	600

189-P**HACKSAW FRAME**

- ▶ for hacksaw blades with 300 mm (12") length
- ▶ including metal saw blade
- ▶ blade position lockable in 6 different positions
- ▶ blade tension by turning the knob in the handle
- ▶ handle made of plastic, hacksaw frame from die-cast aluminium



Code	Number	l/mm	l/Inch	Pieces	Weight/g
0189000102000	189-P	425	11	1	656

189M**HACKSAW FRAME**

- ▶ for saw blades with 300 mm (12") length
- ▶ incl. metal saw blade
- ▶ wooden handle, lacquered steel hacksaw frame



Code	Number	l/mm	l/Inch	Total Length mm	Pieces	Weight/g
0189000001000	189M	300	12	520	1	890

189-WSE, 189-SSE**HACKSAW BLADE, SINGLE CUTTING EDGE**

- ▶ 24 t.p.i.
- ▶ high-speed steel resp. carbon steel with 0.95% C
- ▶ DIN 6494, form A

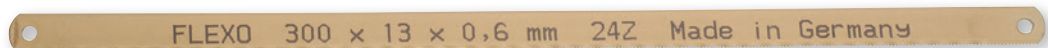

Code	Number	Productinformation	l/mm	l/Inch	Pieces	Weight/g
0189000001001	189-WSE	high grade tool steel with 0,95 % C	300	12	12	15
0189000001002	189-SSE	high-speed steel	300	12	12	30

189-WSD, 189-SSD

HACKSAW BLADE, DOUBLE CUTTING EDGE

- 24 t.p.i.
- high-speed steel resp. carbon steel with 0.95% C
- DIN 6494, form B



Code	Number	Productinformation	l/mm	l/Inch	Pieces	Weight/g
0189000002001	189-WSD	high grade tool steel with 0,95 % C	300	12	12	45
0189000002002	189-SSD	high-speed steel	300	12	12	45

189-K

BIMETAL ROD SAWBLADE

- for round and rectangular cuts
- with eyelets for fixing in hacksaw frames
- coated with a composite alloy with particles of cemented carbide



Code	Number	l/mm	l/Inch	Pieces	Weight/g
0189001000000	189-K	300	12	12	10

257-A, 257-F

JUNIOR HACKSAW FRAME

- ELORA-No. 257-A: with adjustable wooden handle
- ELORA-No. 257-F: with fixed wooden handle
- for marquetry (Coping) saw blades and rod saw blades with 150 mm length
- incl. coping saw blade ELORA-No. 257-S
- Hacksaw frame made of steel



Code	Number	l/mm	Pieces	Weight/g
0257000000000	257-A	190, opened 310	6	141
0257000001000	257-F	285	6	100

257-50

HACKSAW FRAME

- for saw blades and rod saw blades with 150 mm length
- incl. saw blade ELORA-No. 257-S
- handle made of plastic with reinforced glass fiber
- hacksaw frame zinc coated



Code	Number	Radial mm	l/mm	Pieces	Weight/g
0257000507000	257-50	50	250	6	170

257-55

HACKSAW FRAME

- for saw blades and rod saw blades with 150 mm length
- incl. saw blade ELORA-No. 257-S
- handle made of plastic with reinforced glass fiber
- hacksaw frame zinc coated



Code	Number	Radial mm	l/mm	Pieces	Weight/g
0257000557000	257-55	50	255	6	160

257-110

HACKSAW FRAME

- for saw blades and rod saw blades with 150 mm length
- incl. saw blade ELORA-No. 257-S
- handle made of plastic with reinforced glass fiber
- hacksaw frame zinc coated



Code	Number	Radial mm	l/mm	Pieces	Weight/g
0257001107000	257-110	110	255	6	213

257-...

HACKSAW BLADE, FLEXIBLE WIRE SAW

- to use with Hacksaw Frames ELORA-No. 257-...
- specially hardened version with eyelets



Code	Number	Pitch mm	Teeth/Zoll	Use	l/mm	Pieces	Weight/g
0257000006000	257-S	1,0	25	Universal	150	12	3
0257000326000	257-S32	0,8	32	for Metal	150	12	3
0257000506000	257-S50	0,5	50	for Metal, smooth	150	12	3
0257000146000	257-S14	1,8	14	for Wood	150	12	3
0257000003000	257-K	-	-	Flexible wire saw / Universal	-	12	4

257-PS

HACKSAW BLADE SET

- in carton box
- to use with Hacksaw Frames ELORA-No. 257-...
- specially hardened version with eyelets



Code	Number	Contents	Pieces	Weight/g
0257500406000	257-PS	3 pieces of each blade 257-S, S32, S50, S14	1	58

1361-S...

SET OF TWIST DRILLS, HSS-G

- ELORA No. 1361-S19: 19 pcs.
- ELORA No. 1361-S25: 25 pcs.
- rising by 0,5 mm
- in plastic folding box
- high capacity twist drill bits, completely ground
- for steel, cast steel, alloyed and non-alloyed (up to 900 N/mm²)
- high true-running accuracy
- from Ø 3 mm split point according to DIN 1412 C
- point angle 118°
- according to DIN 338 Type N



Code	Number	Contents	Pieces	Weight/g
1361000191000	1361-S 19	from Ø 1,0 till 10 mm, 0,5 mm rising	1	536
1361000251000	1361-S 25	from Ø 1,0 till 13 mm, 0,5 mm rising	1	1104

1362-S...

SET OF TWIST DRILLS HSS-E

- ELORA No. 1362-S19: 19 pcs.
- ELORA No. 1362-S25: 25 pcs.
- rising by 0,5 mm
- in plastic folding box
- high capacity twist drill bits, completely ground
- 5 % Cobalt content provides additional strength and wear resistance
- for steel, cast steel, alloyed and non-alloyed (up to 900 N/mm²), hot and cold work steel, heat-treated and case-hardened steel as well as stainless and acid-resistant steel
- high true-running accuracy
- from Ø 3 mm split point according to DIN 1412 C
- point angle 130°
- according to DIN 338 Type N



Code	Number	Contents	Pieces	Weight/g
1362000191000	1362-S 19	from Ø 1,0 till 10 mm, 0,5 mm rising	1	580
1362000251000	1362-S 25	from Ø 1,0 till 13 mm, 0,5 mm rising	1	1215

1359-S...

COUNTERSINKS 90°, HSS

- 6-pcs.
- in plastic folding box
- for countersinking and deburring
- with cylindrical shaft and 3 flutes
- DIN 335 C



Code	Number	Contents	Pieces	Weight/g
1359000011000	1359-S	Ø 6,3, 8,3, 10,4, 12,4, 16,5, 20,5 mm	1	292

1360-S

THREAD CUTTING ASSORTMENT, HSS

- 15 pcs.
- in plastic case
- for cutting internal threads from M3 to M12
- consisting of bottoming tap, adjustable tap wrench and twist drill
- according to DIN 352



Code	Number	Contents	Pieces	Weight/g
1360000011000	1360-S	Bottoming tap M3x0,5, M4x0,7, M5x0,8, M6x1, M8x1,25, M10x1,5, M12x1,75 twist drill 2,5; 3,3; 4,2; 5,0; 6,8; 8,5; 10,2, adjustable tap wrench 1.1/2"	6	660

1363-S

THREAD CUTTING ASSORTMENT, HSS

- 51 pcs.
- in plastic case with hard foam insert
- for cutting internal and external threads M3 to M12
- consisting of hand taps (3 steps), tap wrench, twist drills, circular dies, die holder and thread gauge
- incl. guides for circular dies
- according to DIN 352



Code	Number	Contents	Pieces	Weight/g
1363000001000	1363-S	hand taps (3 steps) M3x0,5; M4x0,7; M5x0,8; M6x1; M8 x 1,25; M10x1,5; M12x1,75 twist drills: Ø 2,5; 3,3; 4,2; 5,0; 6,8; 8,5; 10,2 tap wrench M3, M4, M5, M6, M8, M10, M12 holder for circular dies 7 guides thread gauge screwdrivers 2 circular dies	1	3900

1363-SF

THREAD CUTTING ASSORTMENT, FINE THREAD, HSS

- 42 pcs.
- in plastic case with hard foam insert
- for cutting internal and external threads Mf3 to Mf12
- Consisting of hand taps (2 steps), tap wrench, twist drills, circular dies, die holder, guideways and thread gauge
- incl. guides for circular dies
- according to DIN 352



Code	Number	Contents	Pieces	Weight/g
1363000011000	1363-SF	hand taps (2 steps): M3x0,35; M4x0,5; M5x0,5; M6x0,75; M8 x 1,0; M10x1; M12x1,5 twist drills: Ø 2,6; 3,5; 4,5; 5,2; 7,0; 9,0; 10,5 2 tap wrench circular dies Mf3, Mf4, Mf5, Mf6, Mf8, Mf10, Mf12 holder for circular dies 7 guides thread gauge screwdriver	1	4000

1365-S

THREAD CUTTING ASSORTMENT, HSS

- 61 pcs.
- in plastic case hard foam insert
- for cutting internal and external threads M3 to M20
- Consisting of hand taps (3 steps), tap wrench circular dies, die holder, guideways and thread gauge
- according to DIN 352

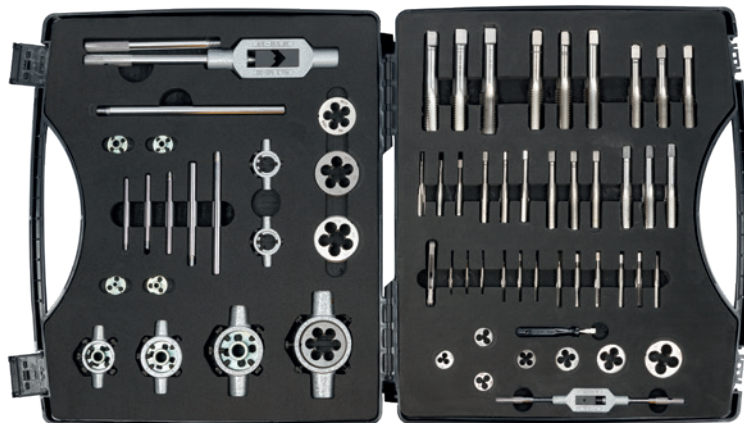

Code	Number	Contents	Pieces	Weight/g
1365000001000	1365-S	hand taps (3 steps): M3x0,5, M4x0,7, M5x0,8, M6x1, M8x 1,25, M10x1,5, M12x1,75, M14x2, M16x2, M18x2,5, M20x2,5, 2 tap wrench circular dies M3 ,M4, M5, M6, M8, M10, M12, M14, M16, M18, M20 6 holder for circular dies 7 guides thread gauge screwdriver	1	7660

1365-SF

THREAD CUTTING ASSORTMENT, FINE THREAD, HSS

- 50 pcs.
- in plastic with case hard foam insert
- for cutting internal and external threads Mf3 to Mf20
- Consisting of hand taps (2 steps), tap wrench circular dies, die holder, guideways and thread gauge
- according to DIN 352



Code	Number	Contents	Pieces	Weight/g
1365000011000	1365-SF	Hand taps (2 steps): Mf3x0,35; Mf4x0,5; Mf5x0,5; Mf6x0,75; Mf8 x 1; Mf10x1; Mf12x1,5; Mf14x1,5;Mf16x1,5; Mf18x1,5; Mf20x1,5 2 tap wrench circular dies Mf3, Mf4, Mf5, Mf6, Mf8 Mf10, Mf12, Mf14, Mf16, Mf18, Mf20 6 holder for circular dies 7 guides thread gauge screwdriver	1	7000

1364-S

THREAD REPAIRING ASSORTMENT

- in plastic case with hard foam insert
- for repairing threads from M5x0,8, M6x1, M8x1,25, M10x1,5, M12x1,75



Code	Number	Contents	Pieces	Weight/g
1364000001000	1364-S	5 twist drills 5 hand taps 5 fitting tools 5 pin-breakers each 25 thread inserts M5 - M10 (High= 1 x Ø) 10 inserts M12 (High= 1 x Ø)	1	2600

4481-...

TAP WRENCH

- for taps
- with sliding T-handle, with reversible ratchet function, chrome plated
- special steel

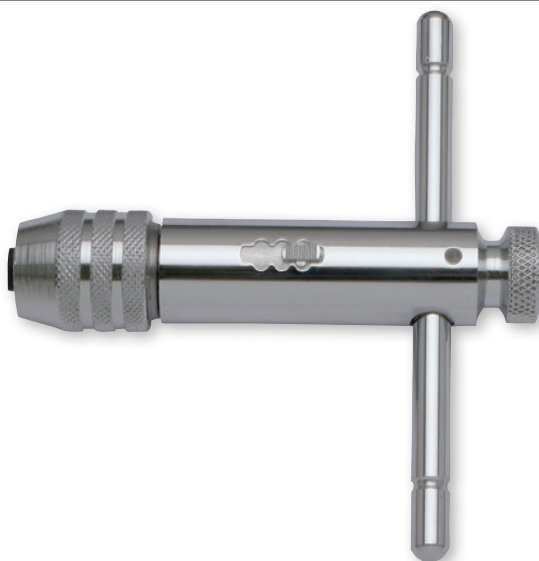

Code	Number	Ø	l/mm	Pieces	Weight/g
4481000551000	4481-5,5	M3-M10	85	1	191
4481000701000	4481-7	M5-M12	110	1	322

310-...

MECHANICAL NUT SPLITTER

- to split fixed or overtightened nuts to strength class 6
- zinc plated, inductive hardened chisel edge
- Heat-treated steel



Code	Number	for Nuts	for Nuts mm	max. Nm	mm	Pieces	Weight/g
0310000106100	310-10	M6	4-10	10	14	1	100
0310000176100	310-17	M10	4-17	40	17	1	280
0310000246100	310-24	M16	8-24	60	17	1	440
0310000366100	310-36	M24	19-36	80	27	1	610

315

HYDRAULIC NUT SPLITTER

- to split fixed or overtightened nuts up to strength class 10
- hydraulic execution
- gunmetal finished spindle
- High grade tool steel C45 / 1.0503



Code	Number	for Nuts mm	Pieces	Weight/g
0315000000000	315	7-22	1	809

316

HYDRAULIC NUT SPLITTER

- to split fixed or overtightened nuts up to strength class 10
- hydraulic execution
- gunmetal finished spindle
- high grade tool steel C45 / 1.0503



Code	Number	for Nuts mm	Pieces	Weight/g
0316000000000	316	22-36	1	2920

350-...

SCREW EXTRACTOR

- for extracting broken screws and bolts with right-hand thread
- chrome vanadium 58CrV4 / 1.8161



Code	Number	Ø Tip mm	Ø Shaft mm	Screws mm	Screws Inches	Drill-Ø mm	Drill-Ø Inches	l/mm	Pieces	Weight/g
0350000064000	350-6	1,75	3,95	M3-M6	1/8-1/4	2,5	3/32	51	12	4
0350000084000	350-8	2,2	4,8	M6-M8	1/4-5/16	3	1/8	60	12	6
0350000114000	350-11	3,3	6,4	M8-M11	5/16-7/16	4,5	11/64	68	12	14
0350000144000	350-14	4,75	8,4	M11-M14	7/16-9/16	6	15/64	76	6	26
0350000184000	350-18	6,35	11	M14-M18	9/16-3/4	8	5/16	86	6	46
0350000244000	350-24	9,5	15	M18-M24	3/4-1	11	7/16	95	6	92
0350000334000	350-33	12,7	19	M24-M33	1-1.3/8	14	9/16	95	6	160
0350000524000	350-52	19	25	M33-M50	1.3/8-2	21	53/64	100	6	550

351S 5, 352S 6, 353S 8

SCREW EXTRACTOR SET

- in black plastic box
- for extracting broken screws and bolts with right-hand thread
- chrome vanadium 58CrV4 / 1.8161



Code	Number	Contents	Pieces	Weight/g
0351500500000	351S 5	350-6, 350-8, 350-11, 350-14, 350-18	1	120
0352500600000	352S 6	350-6, 350-8, 350-11, 350-14, 350-18, 350-24	1	230
0353500800000	353S 8	350-6, 350-8, 350-11, 350-14, 350-18, 350-24, 350-33, 350-52	1	748

242...

OIL SPRAY CAN AND PLASTIC OILER

- 242B-250: steadfast tin pot with a conical shape and a long metal injection pipe
- with reinforced bottom edge, perforated intermediate bottom and pump lever
- ELORA-No. 242K-60 and 242KM ...: unbreakable, flexible plastic container



Code	Number	Capacity	Pieces	Weight/g
0242000600000	242K-60	60 ml	6	10
0242001250000	242KM-125	125 ml	6	40
0242002500000	242KM-250	250 ml	6	60
0242012500000	242B-250	250 ml	1	200

242B-500

OIL SPRAY CAN

- Model with flexible spray tube and pump lever
- Container made of steel, plastic cover



Code	Number	Capacity	Pieces	Weight/g
0242015000000	242B-500	500 ml	6	220

385

HAND LEVER GREASE GUN

- high-quality industrial design with short stroke
- continuous fixation, air release valve on the pump head
- fat lead by means of spring force in the press head
- dummy lubrication excluded
- Working pressure 400 bar, test pressure 800 bar, capacity about 1.9 cc / stroke
- filling can be done with bulk grease (500cc) or cartridge (400g)
- incl. reinforced hose (1000 bar burst pressure) and hollow nozzle
- housing made of steel, painted silver, black plastic handle



Code	Number	Pieces	Weight/g
0385000000000	385	1	1750

291-...

CLAW

- for gripping small parts in hard to reach places
- with flexible shaft, Ø 7 mm
- steel stem, operating piece made of plastic



Code	Number	l/mm	Pieces	Weight/g
0291000000000	291-525	525	6	115
0291010000000	291-1000	1000	6	220

237-...

FLEXIBLE MAGNETIC LIFTER

- for lifting small parts in hard to reach places
- with flexible shaft
- Shaft made of steel
- 2-C QUATROLIT handle with hanging hole

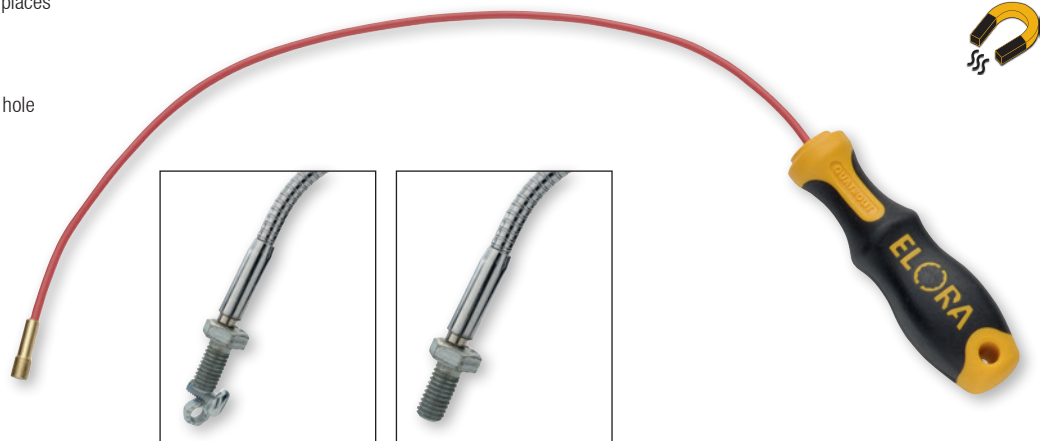

Code	Number	Tractice force	Magnet Ø mm	l/mm	Pieces	Weight/g
0237002300000	237-220	220 g	4	440	6	36
0237005000000	237-500	500 g	6	470	6	75
0237018000000	237-1800	1800 g	12	545	6	220
0237030000000	237-3000	3000 g	16	550	6	285

295

INSPECTION MIRROR

- for inspecting hard to see locations
- round mirror with metal frame
- with flexible shaft
- shaft made of steel
- 2-C QUATROLIT handle with hanging hole



Code	Number	l/mm	Pieces	Weight/g
0295000001000	295	600	1	436

296A

TELESCOPIC MIRROR WITH LIGHTING

- for inspecting hard to see locations
- Round mirror with plastic frame
- illumination with an LED (1x CR2016 battery included)

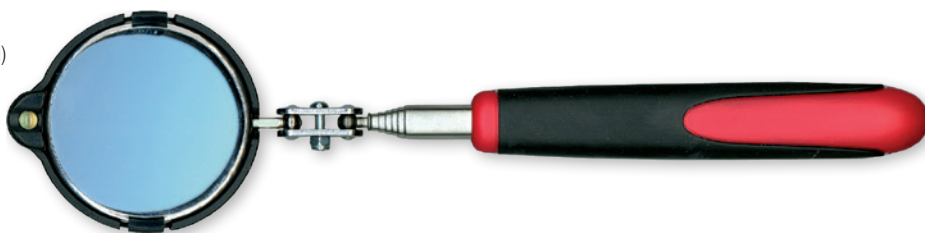

Code	Number	l/mm	Pieces	Weight/g
0296000000001	296A	250-850	1	173

297

INSPECTION SET

- 2-pieces set
- consisting of telescopic magnetic lifter and telescopic search mirror
- packed in a sturdy plastic case
- magnet for lifting of components up to 2,5 kg
- Mirror 45 x 65 mm



Code	Number	Contents	Pieces	Weight/g
0297000000000	297	Telescopic Magnetic Lifter Telescopic Search Mirror	1	300

298

INSPECTION SET WITH QUICK CHANGE CHUCK

- 5-pieces set
- Telescopic shaft with quick change chuck for holding mirror, magnifying glass or magnets
- packed in a sturdy plastic case



Code	Number	Contents	Pieces	Weight/g
0298000000000	298	telescope handle, 210-700 mm length magnet, ø 15 mm, 2,5 kg capacity magnet, ø 8 mm, 1,0 kg capacity mirror 45 x 65 mm magnifying glass 45 x 65 mm	1	307

334-95K

LED HEAD LAMP, DIMMABLE

- with nylon bag
- focusable from homogeneous, circular low beam (defocused) to sharply focused beam (focused)
- with up to 90° vertical, clinching and swivelling lens
- with elastic and adjustable headband
- lamp type high end LED
- light flux from 5 – 200 Lumen
- lightning duration 4 – 60 hours
- light range 20 – 120 m
- splash proof, Standard IPX4
- 3 x AAA batteries included in delivery



Code	Number	Pieces 	Weight/g
0334000951000	334-95K	1	220

336-EX 35

LED LAMP, EXPLOSION-PROOF

- rubberized head-lamp with reduced glare
- rubberized-pressure switch for continuous and instantaneous light
- electrically non-conductive housing made of ABS and polycarbonate
- built-in clip holder on the lamp head
- lamp type eLED, light output 35 lumens
- illumination range 64 meter, burning time approx 3 hrs.
- waterproof up to 1 meter
- Contains 2xAAA batteries
- Ex Certification Zone 1:
II 2G Ex ib IIB T4 Gb, II 2D Ex ib IIIC T60 ° C Db IP6X Db



Code	Number	l/mm 	Pieces 	Weight/g
0336000351000	336-EX 35	132	1	106

336-EX 77

LED LAMP, EXPLOSION-PROOF

- rubberized head-lamp with reduced glare
- rubberized-pressure switch for continuous and instantaneous light
- electrically non-conductive housing made of ABS and polycarbonate
- integrated lanyard hole on the lamp stem
- lamp type eLED, light output 77 lumens
- illumination range 100 Meter, duration of burning appr. 4 hrs.
- waterproof up to 3 Meter
- contains 4xAA Batteries
- Ex Certification Zone 1 SEV 11 ATEX 0174 X, II 2G Ex e ib IIC T4 II 2D Ex ibD 21 T98 ° C
- Accessories such as helmet holder, 90 ° angle attachment, optical fiber attachment upon request



Code	Number	l/mm	Pieces	Weight/g
0336000771000	336-EX 77	170	1	257

335-27

LED PENLIGHT

- with Nylon belt bag, a clip for the shirt pocket and hand strap
- focusable from homogeneous, circular low beam (decofused) to sharply focused beam (focused)
- focus system with reflector lens
- metal housing with non-slip surface
- lamp type high end LED, light flux 18 Lumen
- lightning duration 8,5 hours
- light range 25 m
- 2 x AAA batteries included in delivery



Code	Number	l/mm	Pieces	Weight/g
0335000271000	335-27	138	1	132

335-120

LED LAMP

- with Nylon belt bag, hand strap and roll protection
- focusable from homogeneous, circular low beam (decofused) to sharply focused beam (focused)
- focus system with reflector lens
- metal housing with non-slip surface
- lamp type high end LED, light flux level 1: 25 Lumen, level 2: 220 Lumen
- lightning duration level 1: 5 hours, level 2: 35 hours
- light range level 1: 60m, level 2: 180 m
- splash proof, Standard IPX4, breaking test (dropheight) 1,2 m
- 4 x AAA batteries included in delivery



Code	Number	l/mm	Pieces	Weight/g
0335001201000	335-120	130	1	326

337

LED INSPECTION FLASHLIGHT, SLIM DESIGN

- slim design, perfect for inspection within limited spaces
- with ergonomic handle
- lamp type 15W LED COB, light flux up to 460 Lumen
- continuously dimmable
- 2 fixings: turnable suspension hook, strong magnetic area with swivelling and clampable ball joint
- rechargeable by supplied micro-USB power cable and European charger plug
- with integrated 3,7V Lithium-Ion battery 2200 mAh
- battery indicator: flashing red during charge, shining blue fully charged, flashing yellow running low
- charging time: 4 hours
- lightning duration: full power: 2,5 hours, half power: 12 hours
- operating temperature: 0° to 60°



Code	Number	l/mm	Pieces	Weight/g
0337000001000	337	375	1	

887

SAFETY GOGGLES 3 IN 1

- in neoprene pouch with 2 inside pockets for extra lenses
- frame made of black nylon and anti-slip rubber nose bridges
- adjustable bridge
- with 3 interchangeable plastic lenses (clear, smoke-colored and yellow)
- according to EN166 and CE standard



Code	Number	Pieces	Weight/g
0887000000000	887	1	111

1212

MECHANICS FOAM MAT

- high comfort due to high foam quality
- carrying and hanging handle
- washable
- oil and water-resistant
- made of XPE foam material, black and yellow
- dimensions: 210 x 450 x 30 mm



Code	Number	Pieces	Weight/g
1212000000000	1212	1	120



CONVERSION TABLES FOR TORQUE WRENCHES



Conversion factor								
Unit	SI-Units			metric units		USA- / GB-units		
	cNm	dNm	Nm	cmkg	mkg	ft.lb.	in.lb.	in.oz
1 cNm	1,0000	0,1000	0,0100	0,1020	0,0010	0,0074	0,0885	1,4161
1 dNm	10,0000	1,0000	0,1000	1,0197	0,0102	0,0738	0,8851	14,1612
1 Nm	100,0000	10,0000	1,0000	10,1972	0,1020	0,7376	8,8508	141,6123
1 cmkg	9,8067	0,9807	0,0981	1,0000	0,0100	0,0723	0,8680	13,8874
1 mkg	980,6650	98,0665	9,8067	100,0000	1,0000	7,2330	86,7964	1388,7422
1 ft.lb	135,5818	13,5581	1,3558	13,8255	0,1383	1,0000	12,0000	192,0000
1 in.lb	11,2985	1,1298	0,1130	1,1521	0,0115	0,0833	1,0000	16,0000
1 in.oz	0,7062	0,0706	0,0071	0,0720	0,0007	0,0052	0,0625	1,0000



Example: (,) 1 Nm = 0,1020 mkg (‡)

Conversion Nm → mkg		1 Nm = 0,10197 mkg									
Nm	0	1	2	3	4	5	6	7	8	9	
0	0,00	0,10	0,20	0,31	0,41	0,51	0,61	0,71	0,82	0,92	
10	1,02	1,12	1,22	1,33	1,43	1,53	1,63	1,73	1,84	1,94	
20	2,04	2,14	2,24	2,35	2,45	2,55	2,65	2,75	2,86	2,96	
30	3,06	3,16	3,26	3,37	3,47	3,57	3,67	3,77	3,87	3,98	
40	4,08	4,18	4,28	4,38	4,49	4,59	4,69	4,79	4,89	5,00	
50	5,10	5,20	5,30	5,40	5,51	5,61	5,71	5,81	5,91	6,02	
60	6,12	6,22	6,32	6,42	6,53	6,63	6,73	6,83	6,93	7,04	
70	7,14	7,24	7,34	7,44	7,55	7,65	7,75	7,85	7,95	8,06	
80	8,16	8,26	8,36	8,46	8,57	8,67	8,77	8,87	8,97	9,08	
90	9,18	9,28	9,38	9,48	9,59	9,69	9,79	9,89	9,99	10,10	
100	10,20	10,30	10,40	10,50	10,60	10,71	10,81	10,91	11,01	11,11	

Example: (,) 40 Nm + (‡) 3 Nm = 43 Nm = 4,38 mkg

Conversion mkg → Nm		1 mkg = 9,80665 Nm									
mkg	0	1	2	3	4	5	6	7	8	9	
0	0,00	9,81	19,61	29,42	39,23	49,03	58,84	68,65	78,45	88,26	
10	98,07	107,87	117,68	127,49	137,29	147,10	156,91	166,71	176,52	186,33	
20	196,13	205,94	215,75	225,55	235,36	245,17	254,97	264,78	274,59	284,39	
30	294,20	304,01	313,81	323,62	333,43	343,23	353,04	362,85	372,65	382,46	
40	392,27	402,07	411,88	421,69	431,49	441,30	451,11	460,91	470,72	480,53	
50	490,33	500,14	509,95	519,75	529,56	539,37	549,17	558,98	568,79	578,59	
60	588,40	598,21	608,01	617,82	627,63	637,43	647,24	657,05	666,85	676,66	
70	686,47	696,27	706,08	715,89	725,69	735,50	745,31	755,11	764,92	774,73	
80	784,53	794,34	804,15	813,95	823,76	833,57	843,37	853,18	862,99	872,79	
90	882,60	892,41	902,21	912,02	921,83	931,63	941,44	951,25	961,05	970,86	
100	980,67	990,47	1000,28	1010,08	1019,89	1029,70	1039,50	1049,31	1059,12	1068,92	

Example: (,) 40 mkg + (‡) 3 mkg = 43 mkg = 421,69 Nm

Conversion Nm → ft.lb.		1 Nm = 0,73756 ft.lb.									
Nm	0	1	2	3	4	5	6	7	8	9	
0	0,00	0,74	1,48	2,21	2,95	3,69	4,43	5,16	5,90	6,64	
10	7,38	8,11	8,85	9,59	10,33	11,06	11,80	12,54	13,28	14,01	
20	14,75	15,49	16,23	16,96	17,70	18,44	19,18	19,91	20,65	21,39	
30	22,13	22,86	23,60	24,34	25,08	25,81	26,55	27,29	28,03	28,76	
40	29,50	30,24	30,98	31,72	32,45	33,19	33,93	34,67	35,40	36,14	
50	36,88	37,62	38,35	39,09	39,83	40,57	41,30	42,04	42,78	43,52	
60	44,25	44,99	45,73	46,47	47,20	47,94	48,68	49,42	50,15	50,89	
70	51,63	52,37	53,10	53,84	54,58	55,32	56,05	56,79	57,53	58,27	
80	59,00	59,74	60,48	61,22	61,96	62,69	63,43	64,17	64,91	65,64	
90	66,38	67,12	67,86	68,59	69,33	70,07	70,81	71,54	72,28	73,02	
100	73,76	74,49	75,23	75,97	76,71	77,44	78,18	78,92	79,66	80,39	

Example: (,) 40 Nm + (‡) 3 Nm = 43 Nm = 31,72 ft.lb.

Conversion ft.lb. → Nm		1 ft.lb. = 1,35581 Nm									
ft.lb.	0	1	2	3	4	5	6	7	8	9	
0	0,00	1,36	2,71	4,07	5,42	6,78	8,13	9,49	10,85	12,20	
10	13,56	14,91	16,27	17,63	18,98	20,34	21,69	23,05	24,40	25,76	
20	27,12	28,47	29,83	31,18	32,54	33,90	35,25	36,61	37,96	39,32	
30	40,67	42,03	43,39	44,74	46,10	47,45	48,81	50,16	51,52	52,88	
40	54,23	55,59	56,94	58,30	59,66	61,01	62,37	63,72	65,08	66,43	
50	67,79	69,15	70,50	71,86	73,21	74,57	75,93	77,28	78,64	79,99	
60	81,35	82,70	84,06	85,42	86,77	88,13	89,48	90,84	92,20	93,55	
70	94,91	96,26	97,62	98,97	100,33	101,69	103,04	104,40	105,75	107,11	
80	108,46	109,82	111,18	112,53	113,89	115,24	116,60	117,96	119,31	120,67	
90	122,02	123,38	124,73	126,09	127,45	128,80	130,16	131,51	132,87	134,23	
100	135,58	136,94	138,29	139,65	141,00	142,36	143,72	145,07	146,43	147,78	

Example: (,) 40 ft.lb. + (‡) 3 ft.lb. = 43 ft.lb. = 58,30 Nm

Conversion Nm → in.lb.		1 Nm = 8,85077 in.lb.									
Nm	0	1	2	3	4	5	6	7	8	9	
0	0,00	8,85	17,70	26,55	35,40	44,25	53,10	61,96	70,81	79,66	
10	88,51	97,36	106,21	115,06	123,91	132,76	141,61	150,46	159,31	168,16	
20	177,02	185,87	194,72	203,57	212,42	221,27	230,12	238,97	247,82	256,67	
30	265,52	274,37	283,22	292,08	300,93	309,78	318,63	327,48	336,33	345,18	
40	354,03	362,88	371,73	380,58	389,43	398,28	407,14	415,99	424,84	433,69	
50	442,54	451,39	460,24	469,09	477,94	486,79	495,64	504,49	513,34	522,20	
60	531,05	539,90	548,75	557,60	566,45	575,30	584,15	593,00	601,85	610,70	
70	619,55	628,40	637,26	646,11	654,96	663,81	672,66	681,51	690,36	699,21	
80	708,06	716,91	725,76	734,61	743,46	752,32	761,17	770,02	778,87	787,72	
90	796,57	805,42	814,27	823,12	831,97	840,82	849,67	858,52	867,38	876,23	
100	885,08	893,93	902,78	911,63	920,48	929,33	938,18	947,03	955,88	964,73	

Example: (,) 40 Nm + (‡) 3 Nm = 43 Nm = 380,58 in.lb.

Conversion in.lb. → Nm		1 in.lb. = 0,11298 Nm									
in.lb.	0	1	2	3	4	5	6	7	8	9	
0	0,00	0,11	0,23	0,34	0,45	0,56	0,68	0,79	0,90	1,02	
10	1,13	1,24	1,36	1,47	1,58	1,69	1,81	1,92	2,03	2,15	
20	2,26	2,37	2,49	2,60	2,71	2,82	2,94	3,05	3,16	3,28	
30	3,39	3,50	3,62	3,73	3,84	3,95	4,07	4,18	4,29	4,41	
40	4,52	4,63	4,75	4,86	4,97	5,08	5,20	5,31	5,42	5,54	
50	5,65	5,76	5,87	5,99	6,10	6,21	6,33	6,44	6,55	6,67	
60	6,78	6,89	7,00	7,12	7,23	7,34	7,46	7,57	7,68	7,80	
70	7,91	8,02	8,13	8,25	8,36	8,47	8,59	8,70	8,81	8,93	
80	9,04	9,15	9,26	9,38	9,49	9,60	9,72	9,83	9,94	10,06	
90	10,17	10,28	10,39	10,51	10,62	10,73	10,85	10,96	11,07	11,19	
100	11,30	11,41	11,52	11,64	11,75	11,86	11,98	12,09	12,20	12,31	

Example: (,) 40 in.lb. + (‡) 3 in.lb. = 43 in.lb. = 4,86 Nm

Tool	Page	Tool	Page
Accessories, Roller Tool Cabinets	16, 18	Bi-Hexagon Sockets 1/2"	153, 155
Adapter for Socket Tools 1/4"	199, 203	Bi-Hexagon Sockets 3/4"	183
Adapter for Socket Tools 3/8"	199, 203, 208	Bi-Hexagon Sockets 1"	192
Adapter for Socket Tools 1/2"	203, 208	"BIG SPENDERS", Empty	163, 164
Adapter for Socket Tools 3/4"	208, 214, 219	Bit Adapters	86, 133, 230 - 232
Adapter for Socket Tools 1"	214, 219	Bit-Boxes	231, 232
Adapter for Socket Tools 1.1/2"	219	Bit Couplers	230
Adapters, Bits	86, 133, 230	Bit Holders, Magnetic	230
Adjustable File Holders	456	Bit Holders with Handle	230
Adjustable Pipe Wrenches	337 - 340	Bit Holders with Joint, Universal	230
Adjustable Single Open-Ended Spanners	92, 93	Bits 5/16"	228, 229
Adjustable Wrenches	92, 93	Bits 1/4"	226 - 228
Adjustable Wrenches, VDE	318	Bits for B&S/ XZN Screws	228, 229
Air Blow Guns, Pneumatic	401	Bits for Cross-Slotted Screws	226 - 228
Air Filter Wrenches	434 - 436	Bits for Hexagon Screws	226, 227, 229
Allen Keys	252 - 258	Bits for Phillips Screws	226 - 228
Alphabetic Marking Letters	385	Bits for Pozidriv Screws	226 - 228
Aluminium Grip Pliers	354	Bits for RIBE® Screws	228
Aluminium Rulers	412	Bits for Slotted Screws	226 - 228
American Snips	348	Bits for TAMPER-TORX® Screws	227, 219
Angle Bars	416, 417	Bits for TORX® PLUS Screw	227
Anti-Freeze Testers	432	Bits for TORX® Screws	226, 227 - 229
Anti Slip Mats	16	Bits for TORX® Screws with borehole	227, 219
Anvil Dollies	453	Bits for XZN/ B&S Screws	228, 229
Anvil Round	310	Bits, "INOX"	231
Arch Punches	383, 384	Bits, "STAINLESS"	231
Automatic Punch	379	Blades for Cutters	489
Automatic Safety Knives	488	Blades for Safety Knives	489, 490
Automatic Wire Strippers	312, 327	Blades for Saws	491 - 493
Automotive Striking Tools	451, 452, 454	Blind-Rivet Nut, Pliers	341
Automotive Tools	426 - 470	Blow Pens, Pneumatic	401
Awls, Round	385	Body Spoons	453
Awls, Square	385	Bolt Cutters	342
Axial Grip Pliers	357 - 359	Brake Body Files	449
B & S-XZN®-Off-Set Keys	264	Brake Service Brushes	449
B & S-XZN® Screwdriver Sockets 3/8"	142	Brake Service Files	449
B & S-XZN® Screwdriver Sockets 1/2"	160, 161	Brake Spring Pliers	450
Bags, Notebook	23	Brass Slide Calipers	408
Bags, Tool	23, 24	Brushes	441, 449, 459, 486, 487
Bag Twisters	343	Brushes, Battery Terminal	459
Ball End Hexagon Keys	257 - 259	Brushes, Brake Service	449
Ball End Hexagon Screwdrivers	257 - 259, 270, 276	Brushes, Cup	487
Ball End Hexagon Screwdrivers, ESD	293	Brushes, File Cleaning	486
Ball End Hexagon Screwdriver Sockets 1/2"	159	Brushes, "INOX"	486
Ball End Hexagon-TORX® Screwdrivers	259, 270	Brushes, Knot Conical	487
Ball End Screwdriver Sockets 1/2"	159	Brushes, Knot Cup	487
Ball End TORX® Keys	259	Brushes, Knot Wheel	487
Ball Joint Pullers	461, 462	Brushes, Spark Plug Cleaning	441
Bars, Extension	132, 145, 166, 185, 193, 199, 213, 218, 320, 322	Brushes, "STAINLESS"	486
Bars, Mounting	387	Brushes, Steel Wire	441, 449, 486, 487
Bars, Pry	387	Brushes, Wire Scratch	449, 486, 488
Bars, Wrecking	388, 389	"BUDDY" Roller Tool Cabinets	17
Basin Wrenches	341	Bumping Hammers	451, 452
Battery Acid Fillers	341	Bumping Spoons	453
Battery Acid Testers	460	"C-Clamp" Welders Grip Pliers	352 - 354
Battery Plastic Bottles	460	Cable Knives	304, 316
Battery Service Tool Kits	460	Cable Knives, Universal	304
Battery Terminal Brushes	459	Cable Knives, VDE	316
Battery Terminal Pullers	461	Cable Shears	305, 316
Battery Testers	459	Cable Shears, Copper & PVC Coated Wires	305, 316
Battery Testers, Digital	459	Cable Snips	305, 316
Battery Tools	459	Cable Snips, VDE	316
Belt Punches	344	Cable Terminal Assortments	307, 308
Bench Vice Accessories	390	Cable Terminals	306 - 308
Bench Vice Gas Pressure Elevators	391	Calipers	406 - 408
Bench Vice Jaw Caps	390	Calipers, Brass Slide	408
Bench Vice Swivel Bases	391	Calipers, Depth Vernier	408
Bench Vices, Parallel	390	Calipers, Dial Vernier	407
Bending Irons	453	Calipers, Digital Vernier	408
Bending Pliers	478	Calipers for Brake Discs	408
"Berliner" Tinmans Shears	346	Calipers, Inside	409
Bevel Protractors, Universal	410	Calipers, Outside	406 - 409
Bi-Hexagon Sockets 3/8"	138, 139	Calipers, Pocket Vernier	406, 408
		Calipers, Precision	406 - 408

Tool	Page	Tool	Page
Calipers, Vernier	406 - 408	Concrete and Steel Fixers Nippers	336
Cans, Oil	500	Concrete Chisels	377
Cantilever Tool Boxes	22	Conical Brushes, Knotted	487
Cape Chisels	377	Connector Pliers	341
Car Body Chisels	378	Construction Ring Spanners	113
Car Body File Blades	456	Contact Files	441
Car Body Screwdrivers	271	Converters for Bits	86, 133, 230
Car Tools	426 - 470	Copper Pipe Expanding Tools	478, 480
Car Wing Assembling Screwdrivers	271	Coupler Squares 1/4"	133, 145
Carbide Hexagon Engineers Scribers	422	Coupler Squares 3/8"	133, 145, 166
Carpenters Hammers	371	Coupler Squares 1/2"	145, 166, 186
Carpenters Pincers	335	Coupler Squares 3/4"	166, 186, 193
Carpenters Squares	415	Coupler Squares 1"	186, 193
Cases, Hard-Top	23	Countersinks 90°	494
Cases, Hard Protective	23	Creeper	432
Cases, Hard Protective Trolley	23	Crimping Pliers	306
"Cellulose-Acetate" Soft Faced Hammers	372	Cross Cut Chisels	377
"Cellulose Acetate" Spare Plastic Faces	372	Cross-Slotted Screwdriver Sockets 1/4"	130
Centre Punches	379	Cross-Slotted Screwdriver Sockets 3/8"	140
Centre Squares, Precision	417	Cross-Slotted Screwdriver Sockets 1/2"	157
Chain Grip Pliers	355	Cross-Slotted Screwdrivers	266, 267 -269, 275 - 277, 292, 298, 299, 310
Chain Pipe Cutters	474	Cross-Slotted Screwdrivers, Electronic	292, 298
Chain Tubing Cutters	474	Cross-Slotted Screwdrivers, ESD	292
Checking Tools	406 - 422	Cross-Slotted Screwdrivers, VDE	310
Chipping Hammer	371	Crow Foot Spanners	142
Chisel and Punch Sets	378, 381	Crow Nose Grip Pliers	351
Chisel Hand Grips	378	Cup Brushes	487
Chisel Hand Guards	378	Cup Brushes, Knotted	487
Chisels	376 - 378	Curved Bearing Scrapers	480
Chisels, Cape	377	Curved Dollies	453
Chisels, Car Body	378	Cutter Blades	488 - 490
Chisels, Cold	376	Cutters	488 - 490
Chisels, Concrete	377	Cutters, Bolt	342
Chisels, Cross Cut	377	Cutters, Centre	342
Chisels, Electricians	377	Cutters, Chain Tubing	474
Chisels, Flat	376	Cutters, Diagonal	286 - 288, 312, 326, 332
Chisels, Mason	377	Cutters, End	327
Chisels, Nail	388, 389	Cutters, Exhaust Manifold	474
Chisels, Pointed	377	Cutters, Front	327
Chisels, Sets	378	Cutters, Heavy Duty Diagonal	312, 326
Chisels, Slit	378	Cutters, Heavy Duty End	326, 327
Chisels, Stone	377	Cutters, Heavy Duty Jaw	342
Chubby Screwdrivers	268, 269	Cutters, Lever Centre	342
Circlip Plier-Modules	39, 40, 50	Cutters, Spot-Weld	455
Circlip Pliers	362, 364	Cutters, Structural Steel	343
Circlip Pliers, PVC Coated	363, 364	Cutters, Tubing	474 - 476
Circlip Pliers Set	362, 364	Cutters, Tubing "STAINLESS"	475
Clamps, Flexible Line	430	Cutters, Universal Diagonal	286 - 288, 312, 326, 332
Claw Hammers	371	Cutters, VDE Diagonal	312
Cleaning Brushes for Files	486	Cutters, VDE Heavy Duty Diagonal	312
Cleaning Brushes for Spark Plugs	441	Cutting Assortments, Thread	495, 496
"CLIC"-Hose Clamp Pliers	429	"Dead Blow" Soft Face Hammers	373
Clicking Torque Wrenches	237 -241, 246	Decorative Strip Pliers	457
Clicking Torque Wrenches for invert Tools	241	Depth Vernier Calipers	408
Club Hammer Handles	370	"Desmopan" Soft Faced Hammers	373
Club Hammer Holders	374	"Desmopan" Spare Plastic Faces	373
Club Hammer Wedges	370	Diabolo Dollies	453
Club Hammers	369, 370	Diagonal Cutters	286 - 288, 312, 326, 332
Coil Spring Compressors	427, 428	Diagonal Cutters, Electronic	286 - 288, 297
Combi-Snips, Universal-Angled	349	Diagonal Cutters, VDE	312
Combi-Snips, Universal-Straight	349	Dial Gauge Stands, Magnetic	414
Combination Pliers	313, 327, 332	Dial Indicators, Mini	414
Combination Pliers, VDE	313	Dial Indicators, Precision	414
Combination Spanner-Modules	25 - 28, 44	Diesel Injection Nozzle Sockets 1/2"	442
Combination Spanners	72 - 86	Digital Torque Wrenches	247
Combination Spanners, "STAINLESS"	76	Digital Vernier Calipers	408
Combination Spanners with Joint Ring Ratchets	85	DIN Spanners	94, 109
Combination Spanners with Lever Ring Ratchets	83	Dinging Hammers	451
Combination Spanners with Reversible Ring Ratchet-Modules	29	Dispensers for Sockets, Empty 3/8"	143
Combination Spanners with Reversible Ring Ratchets	83	Dispensers for Sockets, Empty 1/2"	163, 164
Combination Spanners with Ring Ratchet-Modules	25 - 28	Display Dispensers with Socket Assortment 3/8"	143
Combination Spanners with Ring Ratchets	81, 83, 85	Display Dispensers with Socket Assortment 1/2"	163, 164
Combined Revolving Punches and Eyelet Pliers	344	Displays for Construction Ring Spanners	114

Tool	Page	Tool	Page
Displays for Pliers	315, 330	End Cutters	327
Displays for Ring Slogging Spanners	NA	End Cutters, Heavy Duty	327
Dividers	421	End Cutting Pliers	327
Dividers, Spring	421	Engineers Ball Pein Hammer Handles	369
Dividers, Wing	421	Engineers Ball Pein Hammer Wedges	369
Dividers, Wing with Pencil Holder	421	Engineers Ball Pein Hammers	369
Dollies, Anvil	452, 453	Engineers File Hafts	483
Dollies, Curved	452	Engineers File Handles	483
Dollies, Diabolo	452	Engineers File Sets	441, 483, 484
Dollies, Dome	452	Engineers Files, Flat Pattern	441, 481, 484
Dollies, Fender	453	Engineers Files, Half Round Pattern	482, 484
Dollies, General Purpose	452, 453	Engineers Files, Round Pattern	482, 484
Dollies, Grid	452, 454	Engineers Files, Square Pattern	482, 484
Dollies, Heel	452, 455	Engineers Files, Three Square Pattern	482, 484
Dollies, Shrinking	452, 456	Engineers Hammer Handles	368, 369
Dollies, Toe	452, 457	Engineers Hammer Wedges	368, 369
Dollies, Wedge	453	Engineers Hammers	368, 369
Dome Dollies	452	Engineers Rasp Hafts	483
Door-Coating Remove Tools	456, 457	Engineers Rasp Handles	483
Door Opener-Screwdrivers	271	Engineers Rasps	441, 449, 456, 481, 482, 484, 485
Door Spring Clip Removers	457	Engineers Rasps Flat Pattern	441, 480, 484
Door Trim Panel Removers	457	Engineers Rasps Half Round Pattern	482, 484
Double Ended Ring Spanner-Modules	29	Engineers Rasps Round Pattern	482, 484
Double Ended Ring Spanners	98 - 107, 109	Engineers Rulers	413
Double Ended Ring Spanners, Straight	103 - 105	Engineers Scribes	420 - 422
Double Ended Ring Spanners, TORX®	105	Engineers Scribes, Hard Metal	422
Double Ended Spanners	87 - 91, 94	Engineers Steel Squares	415 - 417
Double Ended Swivel Socket Wrenches	105	ESD-Ball End Hexagon Screwdrivers	293
Double Open-Ended Spanner-Modules	25, 26	ESD-Cross Slotted Screwdrivers	292
Double Open-Ended Spanners	87 - 91, 94	ESD-Flat Nose Pliers	290
Double Ring Spanners	98 - 107, 109	ESD-Hexagon Screwdrivers	292, 293
Double Ring Spanners, Straight	103 - 105	ESD-Inside TORX® Screwdrivers	293
Drain Plug Wrenches	436	ESD-Oblique Cutters	288, 289
Drift Punch Sets	380, 382	ESD-Oblique Tip Cutters	289
Drift Punches	382	ESD-Plain Slotted Screwdrivers	292
Drills, Reversible, Pneumatic	397	ESD-Pliers	286 - 291
Drills, Reversible Ø 10 mm, Pneumatic	397	ESD-Round Nose Pliers	290
Drills, Reversible Ø 13 mm, Pneumatic	397	ESD-Screwdrivers	292 - 294
Drill and Tap Sets	495, 496	ESD-Sets	296
Drill Sets	494	ESD-Side Cutters	286 - 288
Drill Sets, HSS-E	494	ESD-Snipe Nose Pliers	290, 291
Drill Sets, HSS-G	494	ESD-TORX® Screwdrivers	293, 294
Drills, Spot-Weld	455	ESD-Tungsten Carbide Side Cutters	288
Drive Heads, Fixed	242	ESD-Tweezers	295, 296
Edge Protectors for Roller Tool Cabinets	16	ESD-Wire Stripping Pliers	289
Electricians Chisels	377	Exhaust Manifold Cutters	474
Electricians Pliers Set	315, 330	Expanding Tools, Copper Pipes	478
Electricians Screwdrivers	266, 309 - 311, 319	Expanding Tools, Copper Tubes	478
Electricians Tool Kits	66, 67	Explosions-Proof, LED Lamp	503, 504
Electricians Tools	66, 67, 303 - 323	Extension Bars 1/4"	132
Electronic Cross Screwdrivers	292, 298	Extension Bars 3/8"	145
Electronic Cross-Slotted Screwdrivers	292, 298	Extension Bars 1/2"	166
Electronic Diagonal Cutters	286 - 288, 297	Extension Bars 3/4"	185
Electronic Flat Nose Pliers	290	Extension Bars 1"	193
Electronic Flat Round Nose Pliers	290, 291	Extension Bars, VDE 3/8"	320
Electronic Pliers	286 - 291, 297	Extension Bars, VDE 1/2"	323
Electronic Screwdriver Sets	299	Extension Bars, Wobble 3/8"	145
Electronic Screwdrivers	292 - 294, 298	Extension Bars, Wobble 1/2"	166
Electronic Slotted Screwdrivers	292, 298	Extension Sockets from 9/32"	133, 145, 199, 203
Electronic Tools	286 - 302	Extension Sockets from 1/4"	133, 145, 166, 199, 203, 208
Electronic Torque Wrenches	247	Extension Sockets from 3/8"	145, 166, 186, 203, 208, 214
Electronic Round Nose Pliers	290, 291	Extension Sockets from 1/2"	166, 186, 193, 208, 214, 219
Electronic TORX® Screwdrivers	293, 294, 298	Extension Sockets from 3/4"	186, 193, 214, 219
Electronic Workshop Test Equipments	NA	Extension Sockets from 1"	219
"ELOMETERS" Torque Wrenches	247	External Circlip Pliers	360, 363
"ELORA-BIG-SPENDERS", Empty	163, 164	Extra Deep/ Long Hexagon Spark Plug Sockets 3/8"	439, 440
"ELORA-BIG-SPENDERS", Socket Assortment 1/2"	163, 164	Extra Deep/ Long Hexagon Spark Plug Sockets 1/2"	440
"ELORA"-Pin-Up Top Trays, Empty	164	Extra Deep/ Long Hexagon Spark Plug Sockets with Magnet 3/8"	440
"ELORA"-Pin-Up Top Trays, Socket Assortment 1/2"	164	Extra Deep/ Long Hexagon Spark Plug Sockets with Magnet 1/2"	440
"ELORA" Socket Display Dispensers, Empty	163		
"ELORA" Socket Display Dispensers,	143		
"ELORA"-TOOLJET Roller Tool CABINET	15		
"ELOTRONIC" Torque Wrenches, Digital	247		
Embossing Hammers	451		

Tool	Page	Tool	Page
Extra Deep/ Long Impact Sockets with Magnet 3/8"	201	Flexible Spark Plug Sockets 1/2"	440
Extra Deep/ Long Impact Sockets with Magnet 1/2"	206	Flexible Steel Rulers	412
Extra Deep/ Long Spark Plug Sockets 3/8"	439, 440	Flexible Wire Saws	493
Extra Deep/ Long Spark Plug Sockets 1/2"	440	Foldable Work Tables	22
Extractor Pullers, Internal Race	467	Folding Pliers	336
Extractor Sets, Screws	499	Folding Rules	411
Extractors	461 - 469	Four Way Wheel Nut Wrenches	445, 446
Extractors, Bearing and Internal Race	467	Gas Pressure Elevators for Bench Vices	391
Extractors, Screws	499	Gauges, Feeler	418, 419
Extractors, Stud	427	Gauges, Feeler Strip	419
Eyelet and Revolving Punch Pliers	344	Gauges, Nozzle	419
Eyes	344	Gauges, Radius	420
Feeler Gauges	418, 419	Gauges, Spark Plug Gauge	442
Feeler Gauges, Strip	419	Gauges, Steel Marking	413
Fender Bumping Hammers	452	Gauges, Steel Marking with Flat Slider	413
Fender Dollies	452	Gauges, Torque Angle	248
Figure Marking Punch Sets	385	Gauges, Tyre Pressure	448
Figure Snips	345- 347	Gauges, Tyre Tread	448
File Blades	456	Geared Head Power Multipliers	249
File Cleaning Brushes	486	General Purpose Dollies	452, 453
File Hafts	483	Glow Plug Pliers	437
File Handles	483	Grease Guns Bodies	500
File Sets, Contact	441	Grease Guns, Lever	500
File Sets for Engineers	441, 483, 484	Grid Dollies	452, 453
File Sets, Warding	484	Grinders, Pneumatic	397 - 399
Files	441, 449, 456, 481, 482, 484, 485	Grinders, Angle Mini Ø 6 mm, Pneumatic	398
Files, Contact	441	Grinders, Angle Ø 125 mm, Pneumatic	398
Files, Engineers Flat Pattern	441, 481, 484	Grinders, Angle Ø 180 mm, Pneumatic	399
Files, Engineers Half Round Pattern	482, 484	Grinders, Straight Mini Ø 6 mm, Pneumatic	397
Files, Engineers Round Pattern	482, 484	Grinders, Wheel Hub	450
Files, Engineers Square Pattern	441, 481, 484	Grip Plier Holders	350
Files, Engineers Three Square Pattern	481	Grip Pliers	350 - 359
Files for Brake Body	449	Grip Pliers, Aluminium	354
Files for Brake Service	449	Grip Pliers, Axial	357 - 359
Files for Thread Restoring	485	Grip Pliers, "C-Clamp" Welders	352 -354
Filter Wrenches	434 -436	Grip Pliers, Chain	355
Fine Mechanic Tools	286 - 302	Grip Pliers, Crow Nose	351
Fine Tooth Ratchets 1/4"	128	Grip Pliers, Long Nose	351
Fine Tooth Ratchets 3/8"	137	Grip Pliers, Micro	357
Fine Tooth Ratchets 1/2"	149, 150	Grip Pliers, Parallel	351
"FIT" Multi Purpose Shear Pliers	335	Grip Pliers, Prismen	350
Fixed Drive Heads	242	Grip Pliers, Universal	350
Fixing Devices for Bench Vices	391	Grip Pliers, Welders	354
Flange Steel Squares	417	Grip Pliers Set, Axial Grip	357 - 359
Flare Nut Open Ring Spanner-Modules	29	Grip Pliers Set	356, 359
Flare Nut Open Ring Spanners	106, 107	Hacking Knives	488
Flaring Jaws	477	Hacksaw Blades	491 - 493
Flaring Tool and Tubing Cutter Sets	478	Hacksaw Frames	491 - 493
Flaring Tool Bodies	477	Hacksaws	491 - 493
Flaring Tools	477, 478	Hacksaws "PUK"	493
Flashlights	503 - 505	Hafts for Files and Rasps	483
Flat Chisels	376 - 378	Half Moon Ring Spanner	109
Flat Nose Pliers	290, 314, 328, 333	Half Round Engineers Files	482, 484
Flat Nose Pliers, Electronic	290	Half Round Pattern Rasp Files	482, 484
Flat Nose Pliers, ESD	290	Hammer Handles	368 - 372
Flat Nose Pliers, Straight VDE	314	Hammer Holders	374
Flat Pattern Engineers Files	441, 481, 484	Hammer Wedges	368 - 372
Flat Pattern Rasp Files	384	Hammers	368 -373
Flat Round Nose Pliers, Straight	290, 314, 328,333	Hammers, Bumping	451, 452
Flat Round Nose Pliers, Bent	313, 328, 333	Hammers, Carpenters	371
Flat Round Nose Pliers, Bent -VDE	313	Hammers, Claw	371
Flat Round Nose Pliers, Electronic	290, 291	Hammers, Club	369, 370
Flat Round Nose Pliers, Straight VDE	313	Hammers, "Dead Blow"	373
Flexible Extension Bars 1/4"	132	Hammers, Dinging	451, 452
Flexible Handles 1/4"	132	Hammers, Embossing	451, 452
Flexible Handles 3/8"	144	Hammers, Engineers	369
Flexible Handles 1/2"	165	Hammers, Engineers Ball Pein	369
Flexible Handles 3/4"	185	Hammers, Pick	451, 452
Flexible Hexagon Nut Drivers	119	Hammers, Planishing	451, 452
Flexible Joint Ratchets 1/2"	151, 152	Hammers, Rubber Mallets	372
Flexible Line Clamps	430	Hammers, Sledge	370
Flexible Magnet Pick-Up Tools	501, 502	Hammers, Soft Faced	372, 373
Flexible Shaft Inspection Mirrors	501, 502	Hammers, Welders Chipping	371
		Hand Anvils	452

Tool	Page	Tool	Page
Hand Striking Tool-Modules	40, 41	Hook Wrenches, Adjustable with Nose	95
Hand Striking Tools	368 - 373	Hook Wrenches, Hinged with Nose	95
Handles, Flexible 1/4"	132	Hooks for Tool Cabinets	22
Handles, Flexible 3/8"	144	Hoses, Compressed Air Signal	402
Handles, Flexible 1/2"	165	Hoses, Pneumatic Spiral, Polyurethan	402
Handles, Flexible 3/4"	185	Hose Clamp Pliers	429, 430
Handles, Club Hammer	370	Hub Pullers	462
Handles, Engineers Ball Pein Hammer	368, 369	Hydraulic Nut Splitters	498
Handles, Engineers Hammer	369	Ignition Spanner Sets	92
Handles, Hammer	368 - 372	IMPACT Adapters 1/4"	199, 203
Handles, Sledge Hammer	371	IMPACT Adapters 3/8"	199, 203, 208
Handles, Soft Faced Hammers	372	IMPACT Adapters 1/2"	203, 208
Handles, Spinner 1/4"	132	IMPACT Adapters 3/4"	208, 214, 219
Handles, Spinner 3/8"	144	IMPACT Adapters 1"	214, 219
Hard-Top Cases	23	IMPACT Adapters 1.1/2"	219
Hard Protective Cases	23	IMPACT Bits 1/4"	229, 230
Hard Protective Trolley Cases	23	IMPACT Bits 5/16"	229, 230
Heads, Sliding 3/4"	186	IMPACT Extension Bars 1/4"	199
Heavy Duty Bolt Cutters	342	IMPACT Extension Bars 3/8"	202
Heavy Duty Diagonal Cutters	312, 326	IMPACT Extension Bars 1/2"	208
Heavy Duty End Cutters	327	IMPACT Extension Bars 3/4"	213, 214
Heavy Duty Jaw Cutters	342	IMPACT Extension Bars 1"	218
Heel Dollies	452	IMPACT Extension Sockets from 1/4"	199
Hexagon Key-Modules	34, 46	IMPACT Extension Sockets from 3/8"	203
Hexagon Keys	252 - 258	IMPACT Extension Sockets from 1/2"	209
Hexagon Keys, VDE	311	IMPACT Extension Sockets from 3/4"	213
Hexagon Keys with Ball End TORX®	259	IMPACT Extension Sockets from 1"	219
Hexagon Keys with Ball Ends	257, 258	IMPACT Locking Pins 1/4"	200
Hexagon Keys with Lateral Uses	256	IMPACT Locking Pins 3/8"	203
Hexagon Keys with Pin	256	IMPACT Locking Pins 1/2"	209
Hexagon Keys with T-Handle	256, 261, 262, 311	IMPACT Locking Pins 3/4"	213
Hexagon Keys with T-Handle, VDE	311	IMPACT Locking Pins 1"	219
Hexagon Keys with T-Handle, TORX®	261	IMPACT Locking Pins 1.1/2"	222
Hexagon Keys with TAMPER-TORX®	263	IMPACT Locking Pins 2.1/2"	225
Hexagon Keys with TORX®	259 - 262	IMPACT Locking Rings 1/4"	200
Hexagon Nut Drivers	118	IMPACT Locking Rings 3/8"	203
Hexagon Nut Drivers, Flexible	119	IMPACT Locking Rings 1/2"	209
Hexagon Nut Drivers with T-Handle	118	IMPACT Locking Rings 3/4"	213
Hexagon Screwdrivers	252 - 258	IMPACT Locking Rings 1"	219
Hexagon Screwdrivers, ESD	292, 293	IMPACT Locking Rings 1.1/2"	222
Hexagon Screwdrivers, VDE	311	IMPACT Locking Rings 2.1/2"	225
Hexagon Socket Spanners	119	IMPACT Reducing Sockets from 1/4"	199
Hexagon Socket Spanners, VDE	318	IMPACT Reducing Sockets from 3/8"	203
Hexagon Sockets 1/4"	129, 130, 198	IMPACT Reducing Sockets from 1/2"	209
Hexagon Sockets 3/8"	138, 140, 141, 201, 202, 320	IMPACT Reducing Sockets from 3/4"	213
Hexagon Sockets 1/2"	154, 155, 158, 159, 204 - 207, 321, 322	IMPACT Reducing Sockets from 1"	219
Hexagon Sockets 3/4"	184, 211, - 213	IMPACT Socket Modules 1/2"	33
Hexagon Sockets 1"	193, 216 - 218	IMPACT Socket Modules 3/4"	33
Hexagon Sockets 1.1/2"	220 - 223	IMPACT Socket Parts 1/4"	199, 200
Hexagon Sockets 2.1/2"	224, 225	IMPACT Socket Parts 3/8"	202, 203
Hexagon Sockets, VDE 3/8"	320	IMPACT Socket Parts 1/2"	209, 209
Hexagon Sockets, VDE 1/2"	321	IMPACT Socket Parts 3/4"	213
Hexagon Spanners	119	IMPACT Socket Parts 1"	218, 209
Hexagon Spark Plug Sockets, Extra Deep - Long 3/8"	439, 440	IMPACT Socket Sets 1/2"-Modules	33, 210
Hexagon Spark Plug Sockets, Extra Deep - Long 1/2"	440	IMPACT Socket Sets 3/4"-Modules	33, 215
Hexagon Tubular Box Spanners	116	IMPACT Socket Sets with Plastic Sleeves 1/2"	443
Hexagon Tubular Box Spanners with Handles	120	IMPACT Sockets 1/4"	198
Holder Clips for Spanners	88	IMPACT Sockets 3/8"	201, 202
Holders for Bits	230	IMPACT Sockets 1/2"	204 - 207
Holders for Chisels	376 - 378	IMPACT Sockets 3/4"	211, 212
Holders for Grip Pliers	350	IMPACT Sockets 1"	216, 217
Holders for Pliers	330	IMPACT Sockets 1.1/2"	220 - 223
Holders for Punches	382	IMPACT Sockets 2.1/2"	224, 225
Holders for Sockets 1/4"	131	IMPACT Sockets, Inside Hexagon 3/8"	202
Holders for Sockets 3/8"	142, 143	IMPACT Sockets, Inside Hexagon 1/2"	207
Holders for Sockets 1/2"	161, 162	IMPACT Sockets, Inside Hexagon 3/4"	213
Holing Pliers	454	IMPACT Sockets, Inside Hexagon 1"	218
Hollow Punches	383, 384	IMPACT Sockets, Inside Hexagon 1.1/2"	221
Hook Sets, Mini	432	IMPACT Sockets, Inside TORX® 1/4"	198
Hook Wrenches	95, 96	IMPACT Sockets, Inside TORX® 3/8"	202
Hook Wrenches with Nose	95	IMPACT Sockets, Inside TORX® 1/2"	206, 207
Hook Wrenches with Pin	96	IMPACT Sockets, Outside TORX® 1/4"	198
		IMPACT Sockets, Outside TORX® 3/8"	202
		IMPACT Sockets, Outside TORX® 1/2"	207

Tool	Page	Tool	Page
IMPACT Sockets, TORX® 1/4"	198	Internal Race and Extractor Pullers	468
IMPACT Sockets, TORX® 3/8"	202	Jaw Caps for Bench Vices	390
IMPACT Sockets, TORX® 1/2"	206, 207	Joiners Sliding Bevels	415
IMPACT Sockets with Magnet 3/8"	201	Joiners Squares	415
IMPACT Sockets with Magnet 1/2"	206	Joint-Combination Ratchet Spanner-Modules	26, 28
IMPACT Sockets with Plastic Sleeves 1/2"	443	Joint-Combination Ratchet Spanners	85
IMPACT Tools	198 - 225, 443	Knife Blades	488 - 490
IMPACT Universal Joints 1/4"	199	Knives	303, 304, 316, 488 - 490
IMPACT Universal Joints 3/8"	203	Knives, Automatic Safety	488
IMPACT Universal Joints 1/2"	208	Knives, Cable	303, 304, 316
IMPACT Universal Joints 3/4"	213	Knives, Hacking	488
IMPACT Universal Joints 1"	219	Knives, Lead	488
Impact Wrenches, Pneumatic	394, 395	Knives, Safety	488
Impact Wrenches 3/8", Pneumatic	394	Knives, VDE	316
Impact Wrenches Mini, 1/2", Pneumatic	394	Knot Conical Brushes	487
Impact Wrenches 1/2", Pneumatic	394	Knot Cup Brushes	487
Impact Wrenches 3/4", Pneumatic	395	Knot Wheel Brushes	487
Impact Wrenches 1/2", Pneumatic	395	Lambda Probes Sockets 1/2"	442
Indicating Torque Wrenches	247	Lambda Probes Tools	442
Indicators	414	Lamps, Inspection	503 - 505
"INOX" Bits	231	Lamps, LED	503 - 505
"INOX" Combination Spanners	76	Lay-Off Pliers	454
"INOX" Screwdrivers	265, 267	Lead Knives	488
"INOX" Spanners	76	Leak Oil Pliers	431
"INOX" Tube Cutters	475	LED Lamps	503 - 505
"INOX" Wire Brushes	486	LED Lamps, Explosions-Proof	503, 504
"INOX" Tools	76, 231, 265, 475, 486	Letter Marking Punch Sets	385
Insert Bit Ratchet Wrenches	229, 230	Lever Centre Cutters	342
Insert Bits for B & S Screws	228, 229	Lever Diagonal Cutters	342
Insert Bits for Cross Screws	226 - 228	Lever for Tyres	447
Insert Bits for Cross-Slotted Screws	226 - 228	Lever Grease Guns	500
Insert Bits for Hexagon Screws	226, 227	Lever Profile Tinmans Shears	345, 346
Insert Bits for Phillips Screws	226 - 228	Leverage Revolving Punch Pliers	344
Insert Bits for Pozidriv Screws	226 - 228	Lifters, Valve Spring	426
Insert Bits for RIBE® Screws	228	Long Nose Grip Pliers	351
Insert Bits for Slotted Screws	226 - 228	Magnet Bit Holders	230
Insert Bits for TAMPER-TORX® Screws	227, 229	Magnetic Pick-up Tools	501
Insert Bits for TORX® Screws	226, 227 - 229	Magnetic Socket Rails	131, 143, 161
Insert Bits for TORX® Screws with a Borehole	227, 229	Mallets, Rubber	372
Insert Bits for XZN Screws	228, 229	Marking Letters	385
Inserting Adapters 9 x 12 mm	245	Marking Tools	385
Inserting Adapters 14 x 18 mm	245	Mason Chisels	377
Inserting Tools for Torque Wrenches	242 - 245	Mat, Foam Mechanics	505
Inside Calipers	420	Measuring Tapes	411, 412
Inside Hexagon, IMPACT Screwdriver Sockets 3/8"	202	Measuring Tools	406 - 422
Inside Hexagon, IMPACT Screwdriver Sockets 1/2"	206	Mechanical Nut Splitters	498
Inside Hexagon, IMPACT Screwdriver Sockets 3/4"	213	Mechanics Foam Mat	505
Inside Hexagon, IMPACT Screwdriver Sockets 1"	218	Mechanics Pliers Set	329, 330, 334
Inside Hexagon, IMPACT Screwdriver Sockets 1.1/2"	221	Micro Grips	357
Inside Hexagon Screwdriver Sockets 1/4"	130	Micrometers, Inside	409
Inside Hexagon Screwdriver Sockets 3/8"	140, 141, 202	Micrometers, Outside	409
Inside Hexagon Screwdriver Sockets 1/2"	158, 159, 207, 322	Midget Open-Ended Spanners	90, 91
Inside Hexagon Screwdriver Sockets 3/4"	184, 213	Mill Blunt Scrapers	480
Inside Hexagon Screwdriver Sockets 1"	193, 218	Mini Dial Indicators	414
Inside Hexagon Screwdriver Sockets, Modules 1/2"	46	Mini-Hook-Sets	432
Inside Hexagon Screwdriver Sockets with Pins 1/2"	159	Mirrors	501
Inside Micrometers	409	Mirrors, Inspection	501
Inside TORX® IMPACT Screwdriver Sockets 1/4"	198	Mirrors, Searching	501
Inside TORX® IMPACT Screwdriver Sockets 3/8"	202	Modules, MS	44 - 50
Inside TORX® IMPACT Screwdriver Sockets 1/2"	206	Modules, OMS	25 - 43
Inside TORX® Screwdrivers, ESD	293	Mounting Bars	387
Inside TORX® Screwdriver Sockets 1/4"	131	Mounting Check Plugs	386
Inside TORX® Screwdriver Sockets 3/8"	141	Mounting Drift Punches	386
Inside TORX® Screwdriver Sockets 1/2"	159, 160, 207	Mounting Punches	386
Inside TORX® Screwdriver Sockets 1/4" with Borehole	131	Mounting Wedges	457
Inside TORX® Screwdriver Sockets 3/8" with Borehole	141	MS-Modules Circlip Pliers	50
Inside TORX® Screwdriver Sockets 1/2" with Borehole	160	MS-Modules Combination Spanners	44
Inspection Lamps	503 - 505	MS-Modules Combination Spanners with Ring Ratchet	45
Inspection Mirrors with Flexible Shafts	501	MS-Modules Pliers	49, 50
Inspection Sets	502	MS-Modules Pliers, VDE	48
Inspection Copes, Fibre Glass	503	MS-Modules Ratchet Combination Spanners	45
Installation Tools	337 - 341, 474 - 478	MS-Modules Screwdriver Sockets, Inside Hexagon Sockets 1/2"	46
Internal Circlip Pliers	360, 363	MS-Modules Screwdriver Sockets, TORX® 1/2"	46
Internal Race and Bearing Extractors	467		

Tool	Page	Tool	Page
MS-Modules Screwdrivers	46 - 48	Outside TORX®, Screwdriver Sockets 3/8"	139, 202
MS-Modules Screwdrivers, VDE	48	Outside TORX®, Screwdriver Sockets 1/2"	156, 206
MS-Modules Socket Sets 1/4"	45	Padlocks	22
MS-Modules Socket Sets 1/2"	46	Panel Beating Sets	453, 454
MS-Modules Spanners	44, 45	Parallel Bench Vice Accessories	390
MS-Modules TORX®-Tools	46	Parallel Bench Vices	390
MS-Modules Wooden Screwdrivers	48	Parallel Grip Pliers	351
Multi Fitting Keys	121	Parts for Sockets 1/4"	128, 132, 133
Multi Purpose Pliers "MULTI-TOOL"	335	Parts for Sockets 3/8"	137, 144, 145, 320
Multi Purpose Shear Pliers "FIT"	335	Parts for Sockets 1/2"	149 - 152, 165, 166, 321, 322
Nail Chisels	388, 389	Parts for Sockets 3/4"	182, 185, 186
Needle Scalers, Pneumatic	399	Parts for Sockets 1"	192, 193
Nozzle Gauges	419	"Pelican" Tinmans Shears	348
Nut Drivers	119	Pick Hammers	451, 452
Nut Drivers, VDE	318	Pick-Up Tools	501
Nut Splitters, Hydraulic	498	Pick-Up Tools with Flexible Magnet	501
Nut Splitters, Mechanical	498	Pin Punch Sets	380, 382
Oblique Cutters, ESD	288, 289	Pin Punches	382
Oblique Tip Cutters, ESD	289	Pin Punches with Guide Sleeve	382
Obstruction Ring Spanners	109	Pin Wrenches	95, 96
Offset Handles 1/2"	165	Pincers, Carpenters	335, 336
Offset Handles 3/4"	185	Pipe and Waterpump Pliers	337 - 340
Offset Lever Tinmans Shears	346	Pipe and Waterpump Pliers, VDE	314
Offset Tinmans Shears	346, 347	Pipe Benders	478
Oil Cans	500	Pipe Cutters	474 - 476
Oil Filter Chain Wrenches	435	Pipe Cutters for Copper Tubes	474, 475
Oil Filter Tools	434 - 436	Pipe Cutters with Chains	474
Oil Filter Wrenches	434 - 436	Pipe Deburrers	476, 477
Oilers, Plastic	500	Pipe Snips	476
OMS Modules Allen Keys	34	Pipe Tools	337 - 341, 474 - 478
OMS Modules, Circlip Pliers	39, 40	Pipe Wrenches	339 - 341
OMS Modules, Combination Spanners "BIG"	25, 28	Pipe Wrenches, American Style	340
OMS Modules, Combination Spanners, Bend	25, 28	Pipe Wrenches, "S-Mouth"	339
OMS Modules, Combination Spanners, Cranked	25, 26	Pipe Wrenches, "STILLSON"	340
OMS Modules, Combination Spanners with Joint and Ring Ratchet	26, 28	Pipe Wrenches, Swedish Style	339
OMS Modules, Combination Spanners with Reversible Ring Ratchet	25, 28	Piston Groove Scraper Spare Parts	428
OMS Modules, Combination Spanners with Ring Ratchet	25, 28	Piston Reset Tools	448
OMS Modules, Double Ended Ring Spanners	26, 28	Piston Ring Compressors	427, 428
OMS Modules, Double Open-Ended Spanners	25, 26	Piston Ring Pliers	428
OMS Modules, Flare Nut Open Ring Spanners	29	Piston Tools	427, 428
OMS Modules, Hand Striking Tools	40, 41	Plain Slotted Screwdrivers, ESD	292
OMS Modules, Hexagon Keys	34	Planishing Hammers	451, 452
OMS Modules, Impact Socket Sets 1/2"	33	Plastic Bottles for Batteries	460
OMS Modules, Impact Socket Sets 3/4"	33	Plastic Oilers	500
OMS Modules, Joint-Combination Ratchet Spanners	26, 28	Plastic Pipe Snips	476
OMS Modules, Open Ended Ring Spanners	25, 26	Plastic Tube Snips	476
OMS Modules, Pliers	38 - 40	Plier Holders	330
OMS Modules, Ratchet Combination Spanners	25, 26, 27, 28	Plier-Line, "Classic"	332, 333, 363, 364
OMS Modules, Ratchet Combination Spanners, Reversible	25, 26, 27, 28	Plier-Modules	38, 39, 40, 49, 50
OMS Modules, Ratchet Ring Spanners	26, 28	Plier, Multi Purpose "FIT"	335
OMS Modules, Ratchet Ring Spanners, Cranked	29	Plier Shears "FIT"	335
OMS Modules, Screwdriver Sockets TORX® 1/2"	34	Pliers, Aluminium "C-Clamp" Welders Grip	352 - 354
OMS Modules, Screwdrivers	34 - 38	Pliers, Aluminium Welders Grip	354
OMS Modules, Socket Sets 1/4"	30, 31	Pliers, Axial Grip	357 - 359
OMS Modules, Socket Sets 3/8"	30, 31	Pliers, Bending	478
OMS Modules, Socket Sets 1/2"	30, 32	Pliers, Blind-Rivet Nut	341
OMS Modules, Socket Sets 3/4"	30, 32	Pliers, Brake Spring	450
OMS Modules, TORX® Tools	34	Pliers, "C-Clamp" Welders Grip	352 - 354
"One-Hand" Adjustable Wrenches	340	Pliers, "Carpenters Pincers"	335, 336
Open Box Wrenches 3/8"	142	Pliers, Chain Grip	355
Open End Slogging Spanners	112	Pliers, Circlip	360, 363
Open End Spanner Heads	142, 243	Pliers, "CLIC"-Hose Clamp	429
Open Ended Ring Spanner-Modules	29	Pliers, Combination	313, 327, 332
Open Ended Ring Spanners	106, 107	Pliers, Combined Revolving Punch and Eyelet	344
Open Ended Spanners	87 - 94, 112, 317	Pliers, "Concrete and Steel Fixers Nippers"	336
Open Ended Ring Spanners Heads	245	Pliers, Connector	341
Outside Calipers	360, 363	Pliers, Crimping	306
Outside Micrometers	409	Pliers, Crow Nose Grip	351
Outside TORX®, Impact Screwdriver Sockets 1/4"	198	Pliers, Decorative Strip	457
Outside TORX®, Impact Screwdriver Sockets 3/8"	202	Pliers, Diagonal Cutter	286 - 288, 312, 326, 332
Outside TORX®, Impact Screwdriver Sockets 1/2"	207	Pliers, Door Spring Clip Remover	457
Outside TORX®, Screwdriver Sockets 1/4"	129, 198	Pliers, Door Trim Panel Remover	457
		Pliers, Electronic Diagonal Cutter	286 - 288

Tool	Page	Tool	Page
Pliers, Electronic Flat Nose	290	Pneumatic Impact Wrenches 1/2"	394
Pliers, Electronic Flat Round Nose	290, 291	Pneumatic Impact Wrenches 3/4"	395
Pliers, Electronic Round Nose	290	Pneumatic Impact Wrenches 1/2"	395
Pliers, ESD	286 - 291	Pneumatic Needle Scalers	399
Pliers, External Circlip	360, 363	Pneumatic Ratchet Wrenches	396
Pliers, Eyelet and Combined Revolving Punch	344	Pneumatic Ratchet Wrenches 1/4"	396
Pliers "FIT" Multi Purpose	335	Pneumatic Ratchet Wrenches 3/8"	396
Pliers, Flat Nose	314, 328, 333	Pneumatic Ratchet Wrenches 1/2"	396
Pliers, Flat Round Nose	313, 328, 332, 333	Pneumatic Sabre Saw Sets	400
Pliers, Folding	336	Pneumatic Spiral Hoses, Polyurethan	402
Pliers, Glow Plug	437	Pneumatic Tire Inflators	401
Pliers, Grip	350 - 359	Pneumatic Tire Inflators, Digital, Gauged	401
Pliers, Heavy Duty Diagonal Cutter	312, 326	Pneumatic Tire Inflators, Gauged	401
Pliers, Heavy Duty End Cutter	327	Pocket Offset Key Sets	255, 260, 263, 264
Pliers, Holder	330	Pocket Vernier Calipers	406, 408
Pliers, Holing	454	Pointed Chisels	377
Pliers, Hose Clamp	429, 430	Power Multipliers	249
Pliers, Hose Clamp "CLIC"	429	Prism Grip Pliers	350
Pliers, Internal Circlip	360, 363	Profile Tinmans Shears	346
Pliers, Lay-Off	454	Protractors, Adjustable	410
Pliers, Leak Oil	431	Protractors, Steel	410
Pliers, Long-Nose Grip	351	Pry Bars	387
Pliers, Micro Grip	357	Pry Spoons	453
Pliers, "Multi-Tool"	335	"PUK" Hacksaws	492
Pliers, Parallel-Grip	351	Puller Sets	463, 468, 469
Pliers, Pincer	335, 336	Puller Sets for Windscreen Wiper Arms	469
Pliers, Piston Ring	428	Puller Sets, V-Belt Pulley	463
Pliers, Prism Grip	350	Pullers	461 - 468
Pliers, "PROFI-Classic"	332, 333, 363, 364	Pullers, Ball Joint	461, 462
Pliers, Revolving Punch	344	Pullers, Battery Terminal	461
Pliers, Revolving Punch with Leverage	344	Pullers, Hub	462
Pliers, Round Nose	290, 314, 329, 333	Pullers, Internal Race Extractor	467
Pliers, Shear "FIT"	335	Pullers, Standard	463 - 465
Pliers, Siphon	341	Pullers, Three Legs	461, 466, 467
Pliers, Spark Plug Socket	437	Pullers, Twin Legs	461, 463 - 465
Pliers, Universal Diagonal Cutter	286 - 288, 312, 326, 332	Pullers, Universal	467
Pliers, Universal Grip	350	Pullers, Universal Ball Joint	461, 462
Pliers, Valve Plate	426	Pullers, Windscreen Wiper Arms	469
Pliers, Waterpump	314, 337, 338	Punch Pliers, Revolving	344
Pliers, Waterpump VDE	314	Punch, Sets Alphabetic	385
Pliers, Wedge Base Bulbs	431	Punch, Sets - Figures	385
Pliers, Welders Grip	354	Punches	379 - 386
Pliers, Wheel Weight	447	Punches, Arch	384
Pliers, Wire Stripper	228, 303, 312, 326, 327	Punches, Automatic	382
Pliers, Wire Twisting	343	Punches, Belt	384
Pliers, VDE Combination	313	Punches, Center	382
Pliers, VDE Diagonal Cutter	312	Punches, Drift	382
Pliers, VDE Flat Nose	314	Punches, Hollow	384
Pliers, VDE Flat Round Nose	313	Punches, Mounting	386
Pliers, VDE Pipe- and Waterpump	314	Punches, Mounting Drift	386
Pliers, VDE Round Nose	314	Punches, Pin	382
Pliers, VDE Universal Diagonal Cutter	312	Punches, Pin with Guide Sleeve	382
Pliers, VDE Wire Stripper	312	Punches, Taper	382
Pliers Set, Axial Grip	357 - 359	Punches, Wad	384
Pliers Set, Circlip	362, 364	Punching Tools	344, 383, 384
Pliers Set, Electricians	330	Push Through Ratchets 1/4"	128
Pliers Set, Grip	356, 359	Push Through Ratchets 3/8"	137
Pliers Set, Mechanic's	329, 334	Push Through Ratchets 1/2"	152
Pliers Set, VDE	315	Push Through Ratchets 3/4"	182
Plumber's Tools	337 - 341, 474 - 478	QUATROLIT®-SCREWDRIVERS	265- 276
Pneumatic Air Blow Guns	401	QUATROLIT® VARIANT BIT BLADES	275, 276
Pneumatic Blow Pens	401	Quick Action Wrenches	340
Pneumatic Compressed Air Signal Hoses	402	Quick Gripping Pliers	338
Pneumatic Drills, Reversible	397	Quick Gripping Universal Pliers	338
Pneumatic Drills, Reversible Ø 10 mm	397	Radiator Petcock Sockets 1/2"	121, 474
Pneumatic Drills, Reversible Ø 13 mm	397	Radio- and Telephone Pliers, Bend	313, 328, 333
Pneumatic Grinders	397 - 399	Radio- and Telephone Pliers, Bend - VDE	313
Pneumatic Grinders, Angle Mini Ø 6 mm	398	Radio- and Telephone Pliers, Straight	290, 291, 313, 328, 332
Pneumatic Grinders, Angle Ø 125 mm	398	Radio- and Telephone Pliers, Straight VDE	313
Pneumatic Grinders, Angle Ø 180 mm	399	Radius Gauges	420
Pneumatic Grinders, Straight Mini Ø 6 mm	397	Rails for Sockets 1/4"	131
Pneumatic Impact Wrenches	394, 395	Rails for Sockets 3/8"	143
Pneumatic Impact Wrenches 3/8"	394	Rails for Sockets 1/2"	161
Pneumatic Impact Wrenches Mini, 1/2"	394	Rasp Files	482, 483

Tool	Page	Tool	Page
Rasp Files, Flat Pattern	483	Ring Spanner Heads	244, 245
Rasp Files, Half Round Pattern	482	Ring Spanner Heads, Open	245
Rasp Files, Round Pattern	483	Roll Holders for Roller Tool Cabinets	16
Rasp Hafts	483	Roller Tool Cabinet Accessories	18, 16
Rasp Handles	483	Roller Tool Cabinet "BUDDY"	17
Rasps	482, 483	Roller Tool Cabinet "TOOLJET"	15
Ratchet Combination Spanners	81, 83, 85	Roller Tool Cabinet Modules, MS	44 - 50
Ratchet Heads, Reversible 1/4"	242	Roller Tool Cabinet Modules, OMS	25 - 43
Ratchet Heads, Reversible 3/8"	242	Roller Tool Cabinet "SUPER CADDY"	14
Ratchet Heads, Reversible 1/2"	242	Roller Tool Cabinet, Cable Rollers 10 m	16
Ratchet Heads, Reversible 3/4"	183	Roller Tool Cabinet, Hook Assortments	22
Ratchet Operated Podger Spanners	194	Roller Tool Cabinet, Machine Holders	22
Ratchet Ring Spanner-Modules	29	Roller Tool Cabinet, Screwdriver Holders	22
Ratchet Ring Spanners	104	Roller Tool Cabinet, Tool Holders	22
Ratchet Spanners	81, 83, 85	Roller Tool Cabinet, Can Holders	16
Ratchet Units 1/2"	242	Roller Tool Cabinet, Drawer Separators	16, 18
Ratchet Units 3/8"	242	Roller Tool Cabinet, Edge Protectors	16
Ratchet Units 3/4"	183	Roller Tool Cabinet, Foldable Trays	16
Ratchet Wrenches, Pneumatic	396	Roller Tool Cabinet, Paper Roll Holders	16
Ratchet Wrenches 1/4", Pneumatic	396	Roller Tool Cabinet, Rear Panels	16
Ratchet Wrenches 3/8", Pneumatic	396	Roller Tool Cabinet, Screwdriver Trays	16
Ratchet Wrenches 1/2", Pneumatic	396	Roller Tool Cabinet, Trays	16, 18
Ratchet Wrenches, Bits	229	Roller Tool Cabinet, Waste Baskets	16
Ratchets 1/4"	128	Roller Tool Cabinet, Wooden Panels	16
Ratchets 3/8"	137	Round Anvils	452, 453
Ratchets 1/2"	149 - 152	Round Awls	385
Ratchets 3/4"	182	Round Nose Pliers	290, 314, 329, 333
Ratchets 1"	192	Round Nose Pliers, Electronic	290
Ratchets, Fine Tooth 1/4"	128	Round Nose Pliers, ESD	290
Ratchets, Fine Tooth 3/8"	137	Round Nose Pliers, VDE	314
Ratchets, Fine Tooth 1/2"	149, 150	Round Pattern Engineers Files	482, 484
Ratchets, Flexible Joint 3/8"	137	Round Pattern Rasp Files	483
Ratchets, Flexible Joint 1/2"	151, 152	Round-Wire Strippers	289, 303, 304, 327
Ratchets, Pushed Through 1/4"	128	Rubber Hammers	372
Ratchets, Pushed Through 3/8"	137	Rubber Mallets	372
Ratchets, Pushed Through 1/2"	152	Rubber Mats	22
Ratchets, Pushed Through 3/4"	182	Rules Folding	412, 413
Ratchets, Reversible 1/4"	128	Rulers, Aluminium	412
Ratchets, Reversible 3/8"	137	Rulers, Engineers	412
Ratchets, Reversible 1/2"	149 - 152	Rulers, Wide Steel	412, 413
Ratchets, Reversible 3/4"	182	"S-Mouth" Pipe Wrenches	339
Ratchets, Reversible 1"	192	Sabre Saw Sets, Pneumatic	400
Ratchets, Reversible-Joint 3/8"	137	Safety Coupling with Push-Button, Pneumatic	403
Ratchets, Reversible-Joint 1/2"	151, 152	Safety Cutter Blades	489
Ratchets, Reversible-VDE 3/8"	320	Safety Cutters	488, 489
Ratchets, Reversible-VDE 1/2"	321	Safety Goggles 3 IN 1	505
Reducing Sockets from 1/4"	133, 145	Safety Knife Blades	489
Reducing Sockets from 3/8"	133, 145, 166	Safety Knives	488, 489
Reducing Sockets from 1/2"	145, 166, 186	Safety Knives, Automatic	488
Reducing Sockets from 3/4"	166, 186, 193	Safety Knives with Holder	489
Reducing Sockets from 1"	186, 193	Sales Displays, Construction Ring Spanners	114
Remove Tools, Door Coating	156, 457	Sales Displays, Ring Slogging Spanners	111
Reversible-Joint Ratchets 1/2"	137	Sales Displays, Sockets	162 - 163
Reversible Ratchet Heads 1/4"	242	Sanitary Tools	64, 65, 337 - 341, 474 - 478
Reversible Ratchet Heads 3/8"	242	Saws	316, 491 - 493
Reversible Ratchet Heads 1/2"	242	Saws, VDE	316
Reversible Ratchet Heads 3/4"	183	Scrapers	479, 480
Reversible Ratchets 1/4"	128	Scrapers, Curved Bearing	480
Reversible Ratchets 3/8"	137	Scrapers, Mill Blunt	480
Reversible Ratchets 1/2"	149 - 152	Scrapers, Three Square Curved Bearing	480
Reversible Ratchets 3/4"	182	Scrapers, Three Square Flat Ground	480
Reversible Ratchets 1"	192	Scrapers, Three Square Hollow Ground	480
Reversible Ratchets, VDE 3/8"	320	Scratch Brushes	449, 486, 487
Reversible Ratchets, VDE 1/2"	321	Screw Extractors	499
Revolving Punch and Eyelet Pliers, Combined	344	Screwdriver Bit Blades	275, 276
Revolving Punch Pliers	344	Screwdriver-Modules	34 - 38, 46 - 48
Revolving Punch Pliers with Leverage	344	Screwdriver-Modules, Wooden	37, 38, 48
RIBE® Screwdriver Sockets 1/2"	161	Screwdriver Sets	253 - 260, 262 - 264, 272 - 274, 278, 299, 311
Ring Ratchet Combination Spanner-Modules	27, 28	Screwdriver Sets, Electronic	299
Ring Ratchet Combination Spanners	81, 83, 85	Screwdriver Sets, INOX	273
Ring Ratchet Combination Spanners with Reversible Handle	83	Screwdriver Sets, "STAINLESS"	273
Ring Ratchet Spanners, Fold on	108	Screwdriver Sets, VDE	311
Ring Ratchet Spanners, VDE	317		
Ring Slogging Spanners	110, 317		

Tool	Page	Tool	Page
Screwdriver Sockets 1/4"	129 - 131, 198	Screwdrivers, TORX®	259 - 263, 270, 271, 276, 293, 294, 298
Screwdriver Sockets 3/8"	139 - 142, 202	Screwdrivers, TORX®, Electronic	293, 294, 298
Screwdriver Sockets 1/2"	156 - 161, 206, 207	Screwdrivers, TORX® with Borehole	263, 271, 293
Screwdriver Sockets 3/4"	184, 213	Screwdrivers, VDE	310, 311, 319
Screwdriver Sockets 1"	193, 218	Screwdrivers, Wooden	277
Screwdriver Sockets 1.1/2"	221	Scriber Products	420 - 422
Screwdriver Sockets for B & S-XZN Screws 3/8"	142	Scribers	422
Screwdriver Sockets for B & S-XZN Screws 1/2"	160, 161	Scribers, Engineers	422
Screwdriver Sockets for Cross-Slotted Screws 1/4"	130	Scribers, Hard Metal	422
Screwdriver Sockets for Cross-Slotted Screws 3/8"	140	Searching Mirrors	501
Screwdriver Sockets for Cross-Slotted Screws 1/2"	157	Separator Sets	466, 469
Screwdriver Sockets for Inside Hexagon Screws 1/4"	130	Separators "Fork"-Type	450
Screwdriver Sockets for Inside Hexagon Screws 3/8"	140, 141, 202	Sets, Chisels	378
Screwdriver Sockets for Inside Hexagon Screws 1/2"	158, 159, 207, 322	Sets, ESD	296
Screwdriver Sockets for Inside Hexagon Screws 1/2", VDE	323	Shear Pliers "FIT"	335
Screwdriver Sockets for Inside Hexagon Screws 3/4"	184, 213	Shears	305, 316, 345 - 349, 476
Screwdriver Sockets for Inside Hexagon Screws 1"	193, 218	Shears, American Pattern	348
Screwdriver Sockets for Inside Hexagon Screws 1.1/2"	221	Shears, Berliner Pattern	346
Screwdriver Sockets for Inside Hexagon Screws with Pin 1/2"	159	Shears, Cable	305, 316
Screwdriver Sockets for Inside TORX® Screws 1/4"	131	Shears, Lever Profile Tinmans	345, 346
Screwdriver Sockets for Inside TORX® Screws 3/8"	141	Shears, Offset Lever Tinmans	346
Screwdriver Sockets for Inside TORX® Screws 1/2"	159, 160, 207	Shears, Offset Tinmans	346, 347
Screwdriver Sockets for Outside TORX® Screws 1/4"	129, 198	Shears, Pelican Tinmans	348
Screwdriver Sockets for Outside TORX® Screws 3/8"	139, 202	Shears, Profile Tinmans	346
Screwdriver Sockets for Outside TORX® Screws 1/2"	156, 206	Shears, Tinmans	345 - 348
Screwdriver Sockets for Phillips Screws 1/4"	130	Shrinking Dollies	452, 453
Screwdriver Sockets for Phillips Screws 3/8"	140	Side Cutters, ESD	385 - 288
Screwdriver Sockets for Phillips Screws 1/2"	157	Single End Ring Spanners	110
Screwdriver Sockets for Pozidriv Screws 1/4"	130	Single End Ring Spanners, Offset	317
Screwdriver Sockets for Pozidriv Screws 1/2"	157	Single End Ring Spanners VDE, Offset	317
Screwdriver Sockets for RIBE® Screws 1/2"	161	Single Open-Ended Spanners	112, 318
Screwdriver Sockets for Slotted Screws 1/4"	130	Single Open-Ended Spanners, Adjustable	92, 93, 318
Screwdriver Sockets for Slotted Screws 3/8"	140	Single Open-Ended Spanners, VDE	318
Screwdriver Sockets for Slotted Screws 1/2"	157	Siphon Pliers	341
Screwdriver Sockets for Tamper-TORX® Screws 1/4"	131	Sledge Hammer Handles	371
Screwdriver Sockets for Tamper-TORX® Screws 3/8"	141	Sledge Hammer Wedges	371
Screwdriver Sockets for Tamper-TORX® Screws 1/2"	160	Sledge Hammers	371
Screwdriver Sockets for TORX® Screws 1/4"	129, 131, 198	Sliding Heads 3/4"	186
Screwdriver Sockets for TORX® Screws 3/8"	139, 141, 202	Sliding T-Bars 1/4"	132
Screwdriver Sockets for TORX® Screws 1/2"	156, 159, 160, 207	Sliding T-Bars 3/8"	144
Screwdriver Sockets for TORX® Screws with Borehole 1/4"	131	Sliding T-Bars 1/2"	165
Screwdriver Sockets for TORX® Screws with Borehole 3/8"	141	Sliding T-Bars 3/4"	185
Screwdriver Sockets for TORX® Screws with Borehole 1/2"	160	Sliding T-Bars 1"	193
Screwdriver Sockets for XZN-B & S Screws 3/8"	142	Slit Chisels	378
Screwdriver Sockets for XZN-B & S Screws 1/2"	160, 161	Slogging Spanner Displays	114
Screwdriver Sockets-Module 1/4"	31	Slogging Spanners	110 - 112
Screwdriver Sockets, TORX®-Modules 1/2"	33	Slogging Spanners, Ring	110
Screwdriver Sockets with Ball End 1/2"	159	Slotted Screwdriver Sockets 1/4"	130
Screwdrivers	252 - 278, 292 - 294, 298, 299, 310, 311, 319	Slotted Screwdriver Sockets 3/8"	140
Screwdrivers, Ball End	257 - 259, 270, 276	Slotted Screwdriver Sockets 1/2"	157
Screwdrivers, Ball End TORX®	259, 270	Slotted Screwdrivers	264 - 266, 268, 275, 277, 292, 298, 310
Screwdrivers, Car Body	271	Slotted Screwdrivers, Electronic	292, 298
Screwdrivers, Car Wing Assembling	271	Slotted Screwdrivers, VDE	310
Screwdrivers, Cross	264, 266 - 269, 292, 298, 310	Snipe Nose Pliers, ESD	290, 291
Screwdrivers, Cross, Electronic	292, 298	Snips	305, 316, 345 - 349, 476
Screwdrivers, Cross-Slotted	264, 266 - 269, 292, 298, 310	Snips, American Pattern	348
Screwdrivers, Cross-Slotted, Electronic	292, 298	Snips, Cable	305, 316
Screwdrivers, Door Opener	271	Snips, Combi	349
Screwdrivers, Electronic	292 - 294, 298	Snips, Figure	346, 347
Screwdrivers, ESD	292 - 294	Snips, Plastic Pipes	476
Screwdrivers, IMPACT	232	Snips, Plastic Tubes	476
Screwdrivers, INOX	265, 267, 273	Snips, Wire	305, 316
Screwdrivers "QUATROLIT®" Line	265 - 276	Socket Accessories 1/4"	128, 132, 133
Screwdrivers "QUATROLIT®-VARIANT" Bit Blades	275, 276	Socket Accessories 3/8"	137, 144, 145, 320
Screwdrivers, Slotted	264 - 266, 268, 275, 277, 292, 298, 310	Socket Accessories 1/2"	149 - 152, 165, 166, 321, 322
Screwdrivers, Slotted, Electronic	292, 298	Socket Accessories 3/4"	182, 183, 185, 186
Screwdrivers, Special for Automotive	271	Socket Accessories 1"	192, 193
Screwdrivers "STAINLESS"	265, 267, 273	Socket Adapters, Ring Ratchet Spanner 1/4"	86
Screwdrivers, Torque	240	Socket Adapters, Ring Ratchet Spanner 3/8"	86
		Socket Adapters, Ring Ratchet Spanner 1/2"	86
		Socket Converter for Bits	86, 133, 230

Tool	Page	Tool	Page
Socket Converters	133, 145, 166, 186, 193, 199, 203, 208, 214, 219	Sockets for TORX® Screws with Borehole 3/8"	141
Socket Display Dispensers	162 - 163	Sockets for TORX® Screws with Borehole 1/2"	160
Socket Parts 1/4"	128, 132, 133	Sockets for XZN-B & S Screws 3/8"	142
Socket Parts 3/8"	137, 144, 145, 320	Sockets for XZN-B & S Screws 1/2"	160, 161
Socket Parts 1/2"	149 - 152, 165, 166, 321, 322	Sockets, Radiator Petcock 1/2"	436
Socket Parts 3/4"	182, 183, 185, 186	Sockets, VDE 3/8"	320
Socket Parts 1"	192, 193	Sockets, VDE 1/2"	321
Socket Rails 1/4"	131	Sockets with Ball End 1/2"	159
Socket Rails 1/4", Magnetic	131	Soft Faces Hammer Handles	372, 373
Socket Rails 3/8"	143	Soft Faces Hammers	372, 373
Socket Rails 3/8", Magnetic	143	Square Awls	385
Socket Rails 1/2"	161	Square, Carpenters	415
Socket Rails 1/2", Magnetic	161	Square, Couplers 1/4"	128
Socket Sets 1/4"	134 - 136	Square, Couplers 3/8"	137
Socket Sets 1/4" + 1/2"	135, 167	Square, Couplers 1/2"	152
Socket Sets 1/4"-Modules	31	Square, Couplers 3/4"	182
Socket Sets 3/8"	146 - 148	Square, Centre	417
Socket Sets 3/8"-Modules	31	Square, Engineers	416
Socket Sets 1/2"	167 - 181, 210, 323	Square, Flauge Steel	417
Socket Sets 1/2", VDE	323	Square, Joiners	415
Socket Sets 1/2" + 1/4"	135, 167	Square Pattern Engineers Files	441, 481, 484
Socket Sets 1/2"-Modules	32, 33	Squares, Steel	416
Socket Sets 3/4"	187 - 191, 215	Suction Lifters	458
Socket Sets 3/4"-Modules	32, 33	Suction Lifters with Flexible Heads	458
Socket Sets 1"	194	Suction Valve Grinders	427
Socket Wrenches, T-Hexagon	118	"SUPER CADDY" Roller Tool Cabinet	14
Socket Wrenches, T-Hexagon with Joint	118	Swivel Bases for Bench Vices	391
Socket Wrenches, T-Hexagon with Joint and Magnet	118	Swivel Socket Wrenches 3/8"	118
Socket Wrenches with Handle	118 - 120	Spanner Heads	242 - 245
Sockets, 1/4"	129 - 131, 198	Spanner Heads, Open End	243
Sockets, 3/8"	138 - 142, 201, 202, 320, 439, 440	Spanner Heads, Ring	244, 245
Sockets, 1/2"	153 - 161, 204 - 207, 321, 322, 440	Spanner Heads, Open Ring	245
Sockets, 3/4"	183, 184, 211, 212	Spanner Modules	25 - 29, 44
Sockets, 1"	192, 193, 216 - 218	Spanners	72 - 117
Sockets, 1.1/2"	220 - 223	Spanners, Adjustable Face Pin	97
Sockets, 2.1/2"	224, 225	Spanners, Combination	72 - 86
Sockets for B & S-XZN Screws 3/8"	142	Spanners, Combination with Ring Ratchet	81 - 85
Sockets for B & S-XZN Screws 1/2"	160, 161	Spanners, Construction Ring	113
Sockets for Cross-Slotted Screws 1/4"	130	Spanners, DIN	94, 109
Sockets for Cross-Slotted Screws 3/8"	140	Spanners, Double Ended	87 - 91
Sockets for Cross-Slotted Screws 1/2"	157	Spanners, Double Ended Ring	98 - 107, 109
Sockets for Diesel Injection Nozzles 1/2"	442	Spanners, Double Open Ring	106, 107
Sockets for Inside Hexagon Screws 1/4"	130	Spanners, Double Ring	98 - 107, 109
Sockets for Inside Hexagon Screws 3/8"	140, 141, 202	Spanners, Double Ring, TORX®	105
Sockets for Inside Hexagon Screws 1/2"	158, 159, 207, 322	Spanners, Flare Nut Open Ring	106, 107
Sockets for Inside Hexagon Screws 3/4"	184, 213	Spanners, Hexagon	118, 119
Sockets for Inside Hexagon Screws 1"	193, 218	Spanners, Hexagon Tubular	115 - 117, 120
Sockets for Inside Hexagon Screws 1.1/2"	221	Spanners, Hook	95, 96
Sockets for Inside TORX® Screws 1/4"	131	Spanners, Ignition	92
Sockets for Inside TORX® Screws 3/8"	141	Spanners, Open End Slogging	112
Sockets for Inside TORX® Screws 1/2"	159, 160, 207	Spanners, Single End Ring	108 - 111, 113, 114, 317
Sockets for Lambda Probes 1/2"	442	Spanners, Single Open Ended	92, 94, 112, 318
Sockets for Outside TORX® 1/4"	129, 198	Spanners, Ratchet	81, 83, 85
Sockets for Outside TORX® 3/8"	139, 202	Spanners, Ring Ratchet	104
Sockets for Outside TORX® 1/2"	156, 206	Spanners, Ring Ratchet VDE	317
Sockets for Phillips Screws 1/4"	130	Spanners, Ring Ratchet, Fold On	108
Sockets for Phillips Screws 3/8"	140	Spanners, Ring Slogging	110 - 112
Sockets for Phillips Screws 1/2"	157	Spanners, Slogging	110 - 112
Sockets for Pozidriv Screws 1/4"	130	Spark Plug Cleaning Brushes	441
Sockets for Pozidriv Screws 1/2"	157	Spark Plug Gauges	442
Sockets for RIBE® Screws 1/2"	161	Spark Plug Socket Pliers	437
Sockets for Slotted Screws 1/4"	130	Spark Plug Sockets, Flexible 1/2"	440
Sockets for Slotted Screws 3/8"	140	Spark Plug System Tools	437 - 442
Sockets for Slotted Screws 1/2"	157	Spark Plug Testers	442
Sockets for Tamper-TORX® Screws 1/4"	131	Spark Plug Wrenches	438
Sockets for Tamper-TORX® Screws 3/8"	141	Spark Plug Wrenches, Tubular	438
Sockets for Tamper-TORX® Screws 1/2"	160	Spare Blades for Hacksaw	492, 493
Sockets for TORX® Screws 1/4"	131	Spare Chains for Chain Tubing Cutter	474
Sockets for TORX® Screws 3/8"	141	Spare Jaw Caps for Bench Vices	390
Sockets for TORX® Screws 1/2"	159, 160, 207	Spare Jaws for Heavy Duty Bolt Cutters	342
Sockets for TORX® Screws with Borehole 1/4"	131	Spare Jaws for Structural Steel Cutters	343
		Spare Parts for Bolt Cutters	342
		Spare Parts for Structural Cutters	343
		Spare Plastic Faces, "Cellulose-Acetate"	372

Tool	Page	Tool	Page
Spare Plastic Faces, "Desmopan"	373	T-Socket Wrenches with Joint	118
Spark Plug Cleaning Brushes	441	T-Socket Wrenches with Joint and Magnet	118
Spark Plug Gauges	442	Tamper-TORX® Hexagon Keys	263
Spark Plug Socket Pliers	437	Tamper-TORX® Screwdriver	271
Spark Plug Sockets, Flexible 1/2"	440	Tamper-TORX® Screwdriver Sockets 1/4"	131
Spark Plug Wrenches	438	Tamper-TORX® Screwdriver Sockets 3/8"	141
Special Automotive Screwdrivers	271	Tamper-TORX® Screwdriver Sockets 1/2"	160
Special Car Tool Assortments	469, 470	Tap and Drill Sets	495, 496
Special Screwdrivers, Automotive	271	Tap Wrenches	497
Special Screwdrivers, Car Body	271	Tape Measurements	411
Special Screwdrivers, Car Wing Assembling	271	Taper Punch Sets	381
Special Screwdrivers, Door Opener	271	Taper Punches	379, 386
Special Screwdrivers, Floodlight Adjusting	271	Telephone- and Radio Pliers, Bend	313, 328, 333
Speed Braces 3/8"	144	Telephone- and Radio Pliers, Bend - VDE	313
Speed Braces 1/2"	165	Telephone- and Radio Pliers, Straight	313, 328, 333, 328, 332
Spinner Handle 1/4"	132	Telephone- and Radio Pliers, Straight VDE	313
Spinner Handle 3/8"	144	Thread Cutting Assortments	495, 496
Spirit Levels	414	Thread Repair Assortments	497
Spot-Weld Cutter Centre Pins	455	Thread Restoring Files	485
Spot-Weld Cutters	455	Three Legs Pullers	461, 465 - 467
Spot-Weld Drills	455	Three Square Curved Bearing Scrapers	480
Spring Dividers	421	Three Square Hollow Ground Scrapers	480
Spring Dividers, Precision	421	Three Square Pattern Engineers Files	481
Spud Wrenches	479	Tightening Spoon	453
Spud Wrench Sets	479	Tinmans Shears	345 - 348
"STAINLESS" Bits	231	Tinmans Shears, "Berliner"	346
"STAINLESS" Combination Spanners	76	Tinmans Shears, "Off-Set"	346, 347
"STAINLESS" Screwdrivers	265, 267, 273	Tinmans Shears, "Pelikan"	348
"STAINLESS" Spanners	76	Tinmans Shears, "Profile"	346
"STAINLESS" Tube Cutter Spare Cutting Wheels	475	Tire Inflators, Pneumatic	401
"STAINLESS" Tube Cutters	475	Tire Inflators, Digital, Gauged, Pneumatic	401
"STAINLESS" Wire Brushes	486	Tire Inflators, Gauged, Pneumatic	401
„STAINLESS“ Tools	76, 231, 265, 267, 273, 475, 486	Toe Dollies	452
Standard Pullers	463 - 465	Tommy Bar Tubes	117
Steel Squares	415 - 417	Tommy Bar Tubes for Spark Plug Wrenches	438
Steel and Concrete Fixers Nippers	336	Tommy Bar Tubes, Stepped	117
Steel Marking Gauge Scribes	412	Tommy Bars 3/4"	186
Steel Marking Gauges	412	Tommy Bars for Wheel Nut Wrenches	444
Steel Marking Gauges with a flat Slider	412	Tool Assortments	52 - 67
Steel Protractors	410	Tool Bags	23, 24
Steel Rulers, Flexible	412	Tool Bags, Notebook	24
Steel Rulers, Wide	412	Tool Boxes	22 - 24
Steel Squares, Engineers	416	Tool Cabinets	21
Steel Squares, Flange	417	Tool Cases	22 - 24
Steel Squares, Precision	416	Tool Kit for Battery Services	460
Steel Wire Brushes	449, 486, 487	Tool Kits	469, 470
Steel Wire Brushes "STAINLESS"	486	Tool Modules	25 - 50
Stepped Tommy Bars	117	Tool Sets	52 - 67
"STILLSON" Pipe Wrenches	340	Tool Trolleys	14, 15, 17
Stone Chisels	377	Tools, Electronic	286 - 302
Storage Units	14 - 67	Tools, Fine Mechanics	286 - 302
Straight-Edge Rulers, Precision	412	Tools, VDE	309 - 323
Strap Wrenches	434, 435	Torque Angle Gauges	248
Striking Ring Spanners	110	Torque Screwdrivers	240
Striking Soft Faces, Cellulose-Acetat	372, 373	Torque Wrenches, Clicking	237 - 241
Striking Soft Faces, Desmopan	373	Torque Wrenches, Digital	247
Striking Soft Faces, Nylon	373	Torque Wrenches, "ELOMETER"	247
Striking Spanners	110 - 112	Torque Wrenches, "ELOTRONIC"	247
Striking Tools	368 - 383	Torque Wrenches, Inserting Adapters 9 x 12 mm	245
Striking Tools, Automotive	451 - 454	Torque Wrenches, Inserting Adapters 14 x 18 mm	245
Structural Steel Cutter Spare Parts	343	Torque Wrenches, "ELOTRONIC"	247
Structural Steel Cutters	343	Torque Wrenches for Inserting Tools	241
Stud Extractors	427	Torque Wrenches for use of Spanner Heads	241
T-Bars, Sliding 1/4"	132	Torque Wrenches, Indicating	247
T-Bars, Sliding 3/8"	144	Torque Wrenches, VDE	321
T-Bars, Sliding 1/2"	165	TORX® Tool-Modules	25, 30, 31, 33 - 35, 45, 46
T-Bars, Sliding 3/4"	185	TORX® Screwdriver Sockets 1/4"	131
T-Bars, Sliding 1"	193	TORX® Screwdriver Sockets 3/8"	141
T-Bars, VDE	320, 322	TORX® Screwdriver Sockets 1/2"	159, 160, 207
T-Hexagon-Joint-Socket Wrenches	118	TORX® Screwdriver Sockets Module 1/2"	33
T-Hexagon-Joint-Socket Wrenches with Magnet	118	TORX® Screwdriver Sockets with Borehole 1/4"	131
T-Joint Socket Wrenches	118	TORX® Screwdriver Sockets with Borehole 3/8"	141
T-Joint Socket Wrenches with Magnet	118	TORX® Screwdriver Sockets with Borehole 1/2"	160

Tool	Page	Tool	Page
TORX® Screwdrivers	259 - 263, 270, 261, 276, 293, 294, 298	VDE-Hexagon Keys with T-Handle	311
TORX® Screwdrivers, Electronic	293, 294, 298	VDE-Hexagon Screwdriver Sockets 1/2"	323
TORX® Screwdrivers, ESD	293, 294	VDE-Hexagon Screwdrivers	318
TORX® Screwdrivers with Borehole	263, 271, 293	VDE-Hexagon Socket Spanners	318
TORX® Screwdrivers with T-Handle	261 - 263	VDE-Hexagon Sockets	320, 321
Tube Benders	479	VDE-Hexagon Sockets 1/2"	321
Tube Box Spanners	115 - 117	VDE-Hexagon Sockets 3/8"	320
Tube Cutters	474 - 476	VDE-Metal Saws	316
Tube Cutters "STAINLESS"	475	VDE-Nut Drivers	318
Tube Deburrers	476, 477	VDE-Pipe- and Waterpump Pliers	314
Tube Snips	476	VDE-Plier Modules	40, 49
Tube Tools	337 - 341, 474 - 479	VDE-Pliers	312 - 313
Tubing Cutter and Flaring Tool Sets	479	VDE-Pliers Set	315
Tubing Cutters	474 - 476	VDE-Reversible Ratchets	320, 321
Tubing Cutters for Copper Tubes	474, 475	VDE-Reversible Ratchets 1/2"	321
Tubing Cutters "INOX"	475	VDE-Reversible Ratchets 3/8"	320
Tubing Cutters "STAINLESS"	475	VDE-Ring Ratchet Spanners	317
Tubing Cutters with Chains	474	VDE-Round Nose Pliers	313
Tubing Tools	337 - 341, 474 - 479	VDE-Screwdriver-Modules	38, 48
Tubular Box Spanners, Hexagon	115 - 117	VDE-Screwdrivers	311
Tubular Spark Plug Wrenches	438	VDE-Single End Ring Spanners, Offset	318
Tungsten Carbide Side Cutters, ESD	288	VDE-Single Open-Ended Spanners	318
Tweezers	295, 296, 300 - 302	VDE-Socket Sets 1/2"	323
Tweezers, ESD	295, 296	VDE-T-Bars	320, 322
Twelve-Sided Sockets 3/8"	138, 139	VDE-Tools	309 - 323
Twelve-Sided Sockets 1/2"	153, 155, 440	VDE-Torque Wrenches 1/2"	321
Twelve-Sided Sockets 3/4"	183	VDE-Universal Diagonal Cutters	312
Twelve-Sided Sockets 1"	192	VDE-Voltage Testers	309
Twin Legs Pullers	461, 463 - 465	VDE-Waterpump Pliers	314
Twist Drills	494	VDE-Wire Strippers	312
Twist Drills, HSS-E	494	Vernier Calipers	406 - 408
Twist Drills, HSS-G	494	Vernier Calipers, Digital	408
Twister	343	Vernier Calipers for Brake Discs	408
Tyre Levers	447	Vernier Calipers, Pocket	406, 408
Tyre Pressure Gauges	448	Vernier Calipers, Precision	406 - 408
Tyre Tread Gauges	448	Vernier Calipers, Precision Dial	407
Universal Ball Joint Pullers	461, 462	Voltage Testers	309
Universal Bevel Protractors	410	Wad Punches	383, 384
Universal Chisel Hand Guards	378	Warding File Sets in a Metal Box	484
Universal Combi Snips, Angled	349	Warding File Sets in a Plastic Wallet	484
Universal Combi Snips, Straight	349	Waterpump Pliers	314, 337, 338
Universal Cutters	488- 490	Waterpump Pliers, VDE	314
Universal Joints 1/4"	133, 199	Wedge Dollies	452, 453
Universal Joints 3/8"	145, 203	Wedges	457
Universal Joints 1/2"	166, 208	Welders "C-Clamp" Grip Pliers	352 - 354
Universal Joints 3/4"	185, 214	Wedges for Club Hammer	370
Universal IMPACT Joints 1/4"	199	Wedges for Engineers Ball Pein Hammer	369
Universal IMPACT Joints 3/8"	203	Wedges for Engineers Hammer	368, 369
Universal IMPACT Joints 1/2"	208	Wedges for Hammer	368 - 372
Universal IMPACT Joints 3/4"	213	Wedges for Sledge Hammer	370
Universal IMPACT Joints 1"	219	Wedges for Soft Faces Hammer	372
Universal Magnet Dial Gauge Stands	414	Wedges for Mounting	457
V-Belt Pulley Puller Sets	463	Welders Grip Pliers	352 - 359
Valve Plate Plier Spare Tips	426	Welding Tools	352 - 355, 371, 455
Valve Plate Pliers	426	Wheel Brushes, Knotted	487
Valve Rotators	448	Wheel Hub Grinders	450
Valve Spring Compressor Spare Parts	426	Wheel Nut Wrench Tommy Bars	444
Valve Spring Compressors	426	Wheel Nut Wrenches for Cars	444, 445
Valve Spring Lifter Tips	426	Wheel Nut Wrenches for Trucks	446
Valve Spring Lifters	426	Wheel Nut Wrenches, Four Way	445, 446
Valve Tools	426, 427	Wheel Nut Wrenches with Cap Remover	444
VDE-Adjustable Wrenches	318	Wheel Tools	443 - 448
VDE-Cable Knives	316	Wheel Weight Pliers	447
VDE-Cable Snips	316	Wide Steel Rulers	412, 413
VDE-Cable Tools	312 - 316	Windscreen Viper Arm Pullers	469
VDE-Combination Pliers	313	Wing Dividers	421
VDE-Diagonal Cutters	312	Wing Dividers with Pencil Holder	421
VDE-Extension Bars	320, 322	Wire Brushes INOX	486
VDE-Extension Bars 1/2"	323	Wire Brushes, "STAINLESS"	486
VDE-Extension Bars 3/8"	320	Wire Brushes, Steel	449, 486
VDE-Flat Nose Pliers	314	Wire Cutters	286 - 288, 297, 312, 326, 332
VDE-Flat Round Nose Pliers	313	Wire Saws, Flexible	492, 493
VDE-Hexagon Keys	311	Wire Scratch Brushes	449, 486

Tool	Page
Wire Snips	305, 316
Wire Strippers	289, 303, 304, 312, 316, 327
Wire Strippers, Automatic	303
Wire Strippers, VDE	312, 316
Wire Stripping Pliers, ESD	289
Wire Twisters	343
Wire Twisting, Pliers	343
Wobble Extension Bars 3/8"	145
Wobble Extension Bars 1/2"	166
Wooden Screwdriver Module	37, 38, 48
Wooden Screwdrivers	277, 278
Work Benches	19, 20, 22
Work Benches, Drawer Separators	20
Work Benches, Hook Assortments	22
Work Benches, Machine Holders	22
Work Benches, Screwdriver Holders	22
Work Benches, Tool Holders	22
Work Tables, foldable	22
Working at the Batteries	459 - 461
Working at the Brakes	408, 448 - 450
Working at the Car Bodies	451 - 458
Working at the Chassis	443 - 450
Working at the Electric Systems	66, 67, 303 - 323
Working at the Engines	426 - 442
Working at the Exhaust Systems	426 - 442
Working at the Injection Nozzles	426 - 442
Working at the Pipes	337 - 341, 474 - 479
Working at the Pistons	427 - 428
Working at the Oil Filters	434 - 436
Working at the Spark Plug Systems	437 - 442
Working at the Tubes	337 - 341, 474 - 479
Working at the Valves	426, 427
Working at the Wheels	443 - 448
Wrecking Bars	388, 389
Wrenches, Adjustable	92, 93, 318
Wrenches, Air Filter	436
Wrenches, Basin	474
Wrenches, Double End Swivel Socket	105
Wrenches, Drain Plug	435, 436
Wrenches, Filter	434 - 436
Wrenches, Four Wheel Nut	445, 446
Wrenches, Hook	95, 96
Wrenches, Hook with Nose	95
Wrenches, Hook with Pin	96
Wrenches, Hook Adjustable with Nose	95
Wrenches, Hook Hinged with Nose	95
Wrenches, Obstruction	90, 91
Wrenches, Oil Filter	434 - 436
Wrenches, Pin	97
Wrenches, Pipe	339 - 341
Wrenches, Pipe "American Style"	340
Wrenches, Pipe "S-Mouth"	339
Wrenches, Pipe "STILLSON"	340
Wrenches, Pipe "Swedish Style"	339
Wrenches, Quick Action	340
Wrenches, Ratchet	229
Wrenches, Spark Plug	438 - 440
Wrench, Spud	474
Wrenches, Strap	434, 435
Wrenches, Swivel Socket	105
Wrenches, T-Hexagon Joint Socket	118
Wrenches, T-Hexagon Joint Socket with Magnet	118
Wrenches, Tap	497
Wrenches, Torque	237 - 247
Wrenches, Tubular Spark Plug	438
Wrenches, Wheel Nut	444 - 446
XZN®-B & S-Offset Keys	264
XZN®-B & S Screwdriver Sockets 3/8"	142
XZN®-B & S Screwdriver Sockets 1/2"	160, 161

Code	Page	Code	Page	Code	Page
OMS-1	26	MS-36	47	110S 8MSB	100
OMS-2	31	MS-37	47	110S 8DIN	100
OMS-3/4	32	MS-38	46	110S 8SBDIN	100
OMS-3/4	32	MS-39	47	110S 10M	100
OMS-5	39	MS-40	48	110S 101M	100
OMS-6	36	MS-41	48	110S 101DIN	100
OMS-7	36	MS-50	45	110S 101DIN-1	100
OMS-8	41	WS-1A	53	110S 12M	100
OMS-9	27	WS-2A	55	110S 12DIN	100
OMS-10	38	WS-3A	57	110S 12DIN-1	100
OMS-11	35	WS-4A	59	110S 6AFSB	100
OMS-12	40	WS-5A	61	110S 61AF	100
OMS-15	26	WS-8A	65	110S 62AF	100
OMS-16	37	WS-10A	67	110S 8AF	100
OMS-17	38	770-L SB	162	110S 8AFSB	100
OMS-18	33	1455-SB	131	110S 12AF	100
OMS-19	28	870-M SB	142	110S 14AF	100
OMS-20	40	770-KL/770-MKL	161	112M-...	101
OMS-34/21	32	1455-KL, 1455-MKL	131	112A-...	101
OMS-22	27	870-KL, 870-MKL	143	112S 5M	101
OMS-23	33	60-...MB	92	112S 3AF	101
OMS-24	33	60-...A	92	112S 5AF	101
OMS-35/25	32	61-MB...	93	113M-...	102
OMS-26	34	61-MB S3	93	113BA-...	102
OMS-27	34	62-BI...	93	113S 3M	102
OMS-28	29	63-1	476	113S 5M	102
OMS-29	29	64	477	113S 3BA	102
OMS-30	27	65-...	474	115-...	104
OMS-31	29	66A-...	339	115G-...	104
OMS-32	28	67E-...	339	117-...	108
OMS-33	28	68SN-...	339	117S 6	108
OMS-34/21	32	70-1	121	117S 11	108
OMS-35/25	32	70-2	121	118-.../118S4	86
OMS-36	36	70-3	121	119TXE-...	105
OMS-37	37	75-...	340	120-...	103
OMS-38	37	85M-...	113	120S 6M	103
OMS-42	40	85A-...	113	120S 8M	103
OMS-43	38	85S.../85L...	114	120S 8DIN	103
OMS-45	41	86M-...	110	120S 10M	103
OMS-46	30	86M-...	110	120S 101M	103
OMS-47	25	86M-...	110	120S 12M	103
OMS-48	35	86A-...	110	120S 12DIN-1	103
OMS-49	31	86S-13	111	121-...	106,107
OMS-50	25	87M-...	112	121A-...	106,107
OMS-51	26	87A-...	112	121S 8M	106
OMS-52	30	88-...	109	122M-...	109
OMS-53	39	100M-...	87	122A-...	109
OMS-54	41	100A-...	87	123M-...	105
WS-1M	52	100S 6M	88	123M-...	105
WS-2M	54	100S 6MSB	89	130-...	337
WS-3M	56	100S 8M	88	131	338
WS-4M	58	100S 8MSB	89	132-...	337
WS-5M	60	100S 8DIN	88	132-S3	337
WS-6M	62	100S 8SBDIN	89	133-250	338
WS-8M	64	100SH	88	134-...	338
WS-9M	63	100-KH 9	88	135-...	338
WS-10M	66	100S 10M	88	135-5 VDE	314
WS OMS-5	42	100S 101M	88	136-...	340
WS OMS-6	43	100S 10DIN-1	88	137	340
MS-2	44	100S 101DIN	88	138	341
MS-6	44	100SH	88	139	474
MS-8	76	100S 12M	88	146M-...	90
MS-10	44	100S 12DIN	88	146A-...	90
MS-11/12	45	100SH	88	146S 8M	90
MS-11/12	45	100S 6AF	88	146S 10M	90
MS-13	46	100S 8AFSB	88	146S 12M	90
MS-14	46	100S 8AF	88	146S 14M	90
MS-21	49	100S 8AFSB	89	155-...	256
MS-23	49	100S 12AF	88	156M-...	91
MS-25	50	110M-...	98,99	156A-...	91
MS-26	50	110A-...	98,99	156BA-...	91
MS-26	50	110S 6M	100	156S 6M	91
MS-32	48	110S 6MSB	100	156S 12M	91
MS-32	48	110S 8M	100	156S 6AF	91

Code	Page	Code	Page	Code	Page
156S 5BA	91	188R-...	419	205-KH9	75
157S...	92	189	491	205S 10M	74
158R-...	255	189M	491	205S 12M	74
159-...	252	189-WSE, 189-SSE	491	205S 12M-1	74
159W-...	256	189-WSD, 189-SSD	492	205S 12MT	75
159L-...	253	189-P	491	205S 12MSB	74
159Z-...	256	189-K	492	205S 16M	74
159KU-...	257	190-...	435	205S 16MT	75
159A-...	252	194-...	419	205S 17M	74
159LA-...	253	195CV-17, 195CV-5/8	445	205S 17MT	75
159KUA-...	257	195WS-...	445	205S 18M	74
159SK-1	255	195CV-...	445	205S 18MT	75
159SK-9M, 159SK-10M	254	195CV-17, 195CV-5/8	445	205S 25M	74
159S-...M	253	195CV-...	445	205S 26M	74
159S-8P	254	196-...	446	205S 26MT	75
159S-KK...	255	197-...	419	205S 8AF	74
159S-7L	254	198	448	205S 8AF-1	74
159S-9L	254	200-...	76	205S 8AFSB	74
159SKU	257	202M-...	86	205S 11AF	74
159SKU C	258	202BA-...	86	205S 12AF	74
159SKU E	257	202S 6M	86	205S 12AFSB	74
159S-KUB	258	202S 8M	86	205S 16AF	74
159SW	256	202S 4BA	86	205S 6W	74
159S-...A	253	203M-...	77	205S 8W	74
159S-9LA	254	203A-...	77	205S 11W	74
160S-KXZN	264	203S 8M	79	206-...	115
162TX-...	259	203S 8M-1	79	206S 8M	115
162LTX...	259	203S 8MT	80	206S 10M	115
162WTX-...	262	203S...MSB	79	207-...	481
162S-KTX	260	203-KH9	80	208-...	481
162-KKTX	260	203S 10M	79	209 S5K	483
162SLTX	259	203S 12M	79	210M-...	116
162S-TXKU	259	203S 12M-1	79	210A-...	116
162S-KTTX	263	203S 12MT	80	210S 6M	117
162S-KKTTX	263	203S 16MT	80	210S 8M	117
162-SWTX	262	203S 26MT	80	210S 10M	117
163	447	203S 8AFT	80	210S 12M	117
164	387	203S 16AFT	80	210S 14M	117
165-...	447	203S 12MSB	79	210S 6AF	117
166	387	203S 16M	79	210S 8AF	117
167	448	203S 17M	79	211-...	117
167-1	448	203S 18M	79	212-...	117
168-...	461	203S 25M	79	213-...	119
169-...	462	203S 26M	79	214-...	118
170-...	444	203S 8AF	79	215-...	119
171-...	444	203S 8ASB	79	216-...	119
172-...	463	203S 10AF	79	216A-...	119
173-...	463	203S 10ASB	79	217-...	120
173K-...	464	203S 12AF	79	218-.../220-...	438
173S	464	203S 16AF	79	219	438
174-50	461	203-...XL	78	222-...	439
174-80/2	461	203S-...XL	78	227	435
174-80/3	461	204-J-...	83	229D	438
175-...	462	204-...	81	230	379
176-...	464	204-R...	85	230-...	426
177-...	466	204A-...	81	230-115	426
178-...	427	204-S8M	81	231-...	386
179-16	475	204-S8AF	81	231-...	386
180-35	475	204-S8M OMS	82	232-...	427
180-76	475	204-S8MT	82	232S-...	428
181	474	204-S8AFT	82	234	426
181-ST...	475	204-R S8M	85	235-...	428
182-26	476	204-J S8M	83	235-60	428
182-42	476	204-J S8M OMS	84	235-...	428
182-63	476	204J-S8MT	84	236-1	435
182-26	476	204RS 12M	85	236-LM-...	118
185-...	444	205-...	72,73	236-LMG-...	118
186	447	205A-...	72,73	237	271
187-160	434	205W-...	72,73	237-220 - 3000	501
187-180	434	205S 8M	74	239	457
187-280	434	205S 8MT	75	240S12	460
188MZ-25	418	205S 8AFT	75	241EK	477
188-...M	418	205 S 16AFT	75	241-...	477
188-...Z	418	205S 8MSB	74	241EB-...	477

Code	Page	Code	Page	Code	Page
241SB-...	478	287	460	400Z-...	384
242...	500	288-...	342	400B-...	385
242B-500	500	289-...	343	401-...	348
243MB	447	290...	480	402-...	345
244-1	430	290-1	456	402/1 S3	345
244-2	430	290...	480	404-S3	329
244-3	430	291-...	501	404-S31	329
244-4	429	292	449	404-S4	330
244-C	429	292-1	449	404-S41	362
245-...	430	293	449	404-S8	362
246-...	481	293BS	449	406-...	478
247-...	482	294	432	407	478
248-...	482	295	501	408	479
249	441	296A	502	411	431
249-S6	441	297	502	432	297
250FB	486	298	502	435	297
250-...	486	301-...	474	458	344
250-ST...	486	302	448	458S-...	344
251	441	303-...	427	460	344
252	459	304-S3	334	461	344
253	457	304-S31	334	462	341
254S-HK	484	304-S4	364	463	437
254S-HB	484	310-...	498	464-...	437
255 K-...	483	314S3	463	465-...	437
256	22	315	498	466A-...	306
257-A, 257-F	483	316	498	466I-...	306
257-...	493	317-...	465	466IH-...	307
257-50	492	318-S5	457	466S-...	307
257-55	493	320-...	465	466S 210, 466S 309	308
257-110	493	321-...	335	466S-...	307
257-PS	493	322-...	465	467-...	306
258...	485	323-...	462	468-BI	326
259-...	186	324S15	469	469	361
260-...	376	325-..., 326-...	466	470-BI...	328
260-S5	378	325S-...	469	471-45 BI...	238
261-...	376	325-..., 326-...	466	471-90 BI...	238
262-...	376	327-...	467	473-J 1-4	360
263-...	377	327K-...	467	473-J 11-41	360
264-...	379	328	462	474-A1-4	360
264K / 264KS	381	329-...	450	474-A11-41	361
265-...	379	331	371	476-BI...	328
266K / 266KS / 266S	381	334-95K	503	477-BI-...	329
267-H...	382	335-27	504	480-...	450
270	459	335-120	504	480-340	450
270-D	459	336-EX 35	503	483L / 483R	346
270-...	380	336-EX 77	504	484L / 484R	346
270-S8	380	337, 337-MG	505	485-BI	327
271-...	380	350-...	499	488-...	347
271K / 271KS / 271S	382	351S 5, 352S 6, 353S 8	499	489-...	336
272-...	479	354-...	455	490-BI...	326
273-...	479	355-...	455	491-2	342
274-...	480	359	386	492-BI...	326
276-...	480	361	378	493 BI	335
277	460	361HS	378	493-1	335
278	460	362-...	377	494 BI	327
280-...	458	364-...	377	494S-0,5 BI	327
280G	458	365-...	377	495-BI...	327
281	304	370-...	332	496	305
281-B	488	371-...	325	497R-300	348
281-KZ	304	372-...	467	498-...	349
281-T	488	372S9	468	498-5	349
281-U	488	372S13	468	498-7	305
281-S	488	373-...	468	499-...	336
281-P, 281-PK	490	374-...	431	500H	350
281-C, 281-CK	490	376-160	333	500-...	350
281-K1	489	377-160	333	500P-...	350
281-K2	489	383-J1-J4	363	500G-250	350
281-KA18, 281-PK	489	383-J11-J41	363	500-S4	356
281TK-..., 281-HK52	489	384-A0-A4	363	501	351
283HS	378	384-A01-A41	364	502-...	351
284-250	346	385	500	502-...	351
285-...	383	389-...	332	504-S8	330
285 S8/285 S10	384	392-...	332	505-...	351
286-...	384	395-...	332	507-165/165S	352

Code	Page	Code	Page	Code	Page
507-280/280S	353	620-TX...	298	770-LTXE...	156
507-460	353	620-TTX...ESD	293	770-SIN...	184
507-600/600S	353	625-...ESD	292	770-LA...	153
507A-...	354	625-KU...ESD	293	770SA-...	183
508-...	351	625-...ESD	293	770-LTA...	155
509-500	354	625-KU...ESD	293	770-LW...	153
510-280	355	625-...ESD	293	770SW-...	183
511-280	355	630-...ESD	293	770-LSP1M	162
512-180	352	636-IS...	277	770-LSP2M	163
513	357	649-IS...	266	770-LSP1L	162
514	358	656-PH...	277	770-LSP2L	163
515	358	658-PZ...	277	770-KS	163
516	358	670 S7-K, 673 S7-K	278	770-KS1M	163
517	359	676 S5-K / 677 S5-K	278	770-KS2M	164
518	359	714-6MU	135,167	770-AS	164
519	357	714-6MU OMS	135,167	770-AS2M	164
519S-6	359	730-...	264	770-LTIU	173
520	275	740-...	264	770-LTIK	173
524-...	355	745	385	770-LTU	174
525-...	343	746	385	770-LTK	174
527-TX...	276	760-TX 30/300	271	770-LMU	171
527 S4	276	760TX-...	270	770-LMK	171
535-IS 4	275	760/761STX-...	274	770-OKLMU	170
539-IS	265	761TTX-...	271	770-OKLMK	170
539/1-IS...	265	760/761STX-...	274	770-LMF	171
539-IS	265	762TX-...	261	770-LAU	171
539/1-IS...	265	762-TX20/300	261	770-LAK	171
543-IS...	268	762-TX30/300	261	770-OKLAU	170
545-IS...	266	762TX-...	261	770-OKLAK	170
545-ST IS...	265	762TTX-...	263	770-LAF	171
547-PH...	267	765-...	194	770-LINDMU	169
547-ST PH...	267	770-LM...	153	770-LINDMF	169
549-PZ...	268	770-L1K	149	770-LINDMK	169
551-PH...	275	770-L1D	149	770-LINDAU	169
552-PZ...	275	770-L1F	149	770-LINDAF	169
554-PZ...	269	770-L1UN	150	770-LINDAK	169
555-PH...	269	770-L115U	150	770-LAMU	172
557-PH 12	275	770-L115F	150	770-OKLAMU	172
559-PH...	267	770-L1G	151	770-LSSMF	173
559/1-PH...	266	770-L1GF	151	770-LKMU	168
561	309	770-L115G	151	770-LKMK	168
563	309	770-L115GF	152	770-LKAU	168
564N	309	770-L1ZI	152	770-LKAK	168
566-...	309	770-L115U	150	770-LIMU	176
567-PZ 12	276	770-L2	165	770-LIMK	176
569-PZ...	268	770-L3	165	770-OKLIMU	176
573TX-...	270	770-L35-L66	166	770-OKLIMK	176
575-...	269	770-L...V	166	770-INM	174
577-...	276	770-L7	166	770-INMTIN	174
579 S5-K, 581 S5-K	272	770-L8	165	770-INA	174
580-45	442	770-L9/770-L10...	165	770-TXE	179
579 S5-K, 581 S5-K	272	770SM-...	183	770-XZN	177
582 S5-K...	272	770SA-...	183	770-KINMU	175
582 S5-K...	272	770-L11-L14	166	770-KINMK	175
583 S...	272	770-S9-S11	166	770-KINAU	175
583 S...	272	770-L16-17-18	157	770-KINAK	175
583 S...	272	770-S1U	182	770-KXZNU	177
583 S6K...	273	770-S1ZI	182	770-KXZNK	177
583 S6K...	273	770-S1K	182	770-LXZNU	178
583 S6K-ST	273	770-S2	185	770-LXZNK	178
583 S7-K...	273	770-S3	185	770-OKLXZNU	177
583 S7-K...	273	770-S4/-S5/-S15	185	770-OKLXZNK	177
586	431	770-S6	185	770-TX	178
590-S	432	770-S7	186	770-TTX	178
600-IS...	298	770-S8	186	770-KTXU	179
600-IS...ESD	292	770-S9-S11	186	770-KTXK	179
600-S15	296	770-L21	436	770-KTTXU	179
610-PH...	298	780-7/770-S11	186	770-KTTXK	179
610-PH...ESD	292	770-S13	186	770-RDS12MU	181
612-PZ...	298	770-S14	185	770-S10 OKM	187
616-S6	299	770-L22	436	770-S10 OKA	187
617-S6	299	770-LT...	155	770-S10 MU	187
618-S6	299	770-LTA...	155	770-S10 MZ	187
620-TX...ESD	294	770-LTD	442	770-S10 AU	187

Code	Page	Code	Page	Code	Page
770-S10 AZ	187	780-2	193	870-2	144
770-S10 KM	188	780-3-4	193	870-...	138
770-S10 KA	188	780M-...	192	870-V...	145
770-S12 MU	188	780A-...	192	870-7	144
770-S12 AU	188	780-IN...	193	870-8	144
770-S15 MU	189	780-7/770-S11	193	870-9	145
770-S15 MZ	189	780-10...	194	770-870-1450	145
770-S15 AU	189	788-M...	198	1450-13-15	133
770-S15 AZ	189	788A-...	198	870-11	140
770-S24/1 MU	191	789-...	201	870-12	144
770-S24/1 MZ	191	789IN-...	202	870-TXE...	139
770-S26 AU	191	789MG-...	201	870-A...	138
770-S26 AZ	191	789A-...	201	870-W...	138
770-L20-...	440	790-...	204	870-MU	147
771-LM...	154	790DW-...	443	870-AU	147
771SM-...	184	790IN-...	207	870-JMU	146
771-LT...	155	790TX-...	207	870-JAU	146
771LTZ-...	440	790MG-...	206	870-JSU	146
771LMG-...	440	790LT-...	205	870-INMU	148
771LTZ-...	440	790LTP...	443	870-TXU	148
771LTZ-...	440	790A-...	204	870-TTXU	148
771-LTA...	155	790INA-...	207	870-INAU	148
771-LA...	154	790LTA-...	205	871-M...	138
771-LSP1M	162	790S6...	210	871TZ-...	439
771-LSP2M	163	790 S12...	210	871TMG-...	440
771-KS1M	164	790 S6LT	210	871-A...	138
771-LMITXU	180	790-LTPS3	443	871-JMU	146
771-LMITXK	180	790S6...	210	871-JSU	146
771-LMITTXU	180	790 S12...	210	871-MU	147
771-LMITTXK	180	791-...	211	874-2	436
771-LMU	171	791IN-...	213	875	436
771-LMK	171	791LT-...	212	877-TXE	148
771-OKLMU	170	791A-...	211	887	505
771-OKLAK	170	791INA-...	218	890-...	95
771-LMF	171	791A-...	211	890-VG...	95
771-LINDMU	169	791LTA-...	212	890-V...	95
771-LINDAU	169	791 S5...	215	891-...	96
771-LINDAK	169	791 S10...	215	892-...	97
771-LINDMF	169	791 S6LT	215	894-...	94
771-LINDMK	169	791 S5...	215	895-...	94
771-LINDAF	169	791 S10...	215	900IS-...	310
771-LAU	171	792-...	216	900IS-...	310
771-LAK	171	792IN-...	218	904-S3	315
771-OKLAU	170	792LT-...	217	904-S10	315
771-OKLAK	170	792A-...	216	905-...	319
771-LAF	171	792INA-...	218	910PH-...	310
771-LAMU	172	792LTA-...	217	912PZ-...	310
771-OKLAMU	172	793-...	220,221	920-165	314
771-LXZNU	178	793IN-...	221	930-...	313
771-LXZNK	178	793LT-...	222,223	935-45...	313
771-OKLXZNU	177	793A-...	220,221	935-90 205	313
771-OKLXZNK	177	793INA-...	221	940-165	314
771-LKMU	168	793LTA-...	222,223	949 H	330
771-LKMK	168	794-...	224,225	950-...	312
771-LKAU	168	794A-...	224,225	955-...	312
771-LKAK	168	795-1/4	199	956-...	311
771-LIMU	176	795-3/8	203	959-L...	311
771-LIMK	176	795-1/2	208	960-...	313
771-OKLIMU	176	795-3/4	213	961-...	318
771-OKLIMK	176	795-1	219	966	320
771-LSSMF	173	796-E...	198	967-...	320
771-S10 OKM	187	797-E...	202	968	320
771-S10 MU	187	798-E...	206	969-...	320
771-S10 MZ	187	800L/810L	22	970-160	312
771-S10 KM	188	803L/813L	22	971-IN...	322
771-S12 MU	188	855-...	113	971-...	321
771-S15 MU	189	870-M...	138	971-S13	323
771-S15 MZ	189	870-1D	137	972	321
771-S24/1 MU	191	870-1UN	137	973	322
771-S24/1 MZ	191	870-T...	139	974-...	322
771-RDS12MU	181	870-1ZI	137	977	316
776L-9	442	870-1D	137	977H	309
779-...	142	870-1ZI	137	977A	309
780-1	192	870-1UN	137		

Code	Page	Code	Page	Code	Page
979S-5K	304	1455-PZ...	130	1650S6	453
980-165	305	1455-T...	129	1650S12	454
985	309	1455-TXE...	129	1660-...	372
986-...	317	1455A-...	129	1660E-...	372
987-...	318	1455-INA...	130	1660ST-...	372
988-...	317	1483-...	347	1660KL-...	372
989-...	316	1484-...	347	1661-...	373
990	321	1495-...	390	1661E-...	373
1080, 1081, 1082	303	1495D-...	391	1665-...	368
1083	304	1495L-135	391	1665-K...	368
1094	303	1500A-... / 1500K-...	390	1665ST-...	368
1095	303	1510	406	1665KL-...	368
1100L	21	1511	406	1666	432
1110-...	16	1512	406	1666-Z	433
1115	437	1513	406	1670-...	369
1200-RM 18	16	1515-...	407	1670ST-...	369
1210-L	17	1515-...	407	1670KL-...	369
1210-...	18	1517-...	408	1672-K...	370
1210-ET...	18	1519	408	1672-...	369
1212	505	1520-...	407	1672ST-...	370
1220-L	14	1522-300	407	1672KL-...	370
1220-...	16	1523	408	1673-...	370
1220-TBS..., 1220-FTS...	16	1524-...	408	1673ST-...	371
1220-...	16	1530-...	409	1673KL-...	371
1220-...	16	1530S4	409	1675/2-...	388
1225-L7	15	1532-...	409	1676/1-...	388
1227-L	21	1535-...	410	1676/2-...	388
1300...	470	1537-...	410	1676/3-...	389
1344-...	482	1541-...	410	1676/4-...	389
1345-...	483	1544H	411	1676/6-...	389
1346-...	483	1545-...	412	1678	371
1347-S160	484	1546-...	411	1680-330	371
1359-S...	494	1546XL-...	411	1690-...	373
1360 S	495	1547-...	412	1690E-...	373
1361-S...	494	1552-...	412	1810-L	20
1362-S...	494	1553-...	413	1811-L	19
1363-S	495	1554-...	414	1815	22
1363-SF	495	1555	414	2011-1000	240
1364-S	497	1557	414	2033-20	241
1365-S	496	1565	414	2034-...	241
1365-SF	496	1566GU-...	415	2034-200 S13M	246
1380-L	23	1566H-...	415	2052-..., 2056-...	243
1381-L	23	1567GU-...	415	2062-..., 2066-...	244
1385-L	24	1567H-...	415	2063-...	245
1386-L	24	1569-...	416	2062-..., 2066-...	244
1400-IMU	135	1570-.../1571-...	416	2070-...	239
1400-IAU	135	1577-...	417	2071-...	245
1400-TXE	136	1578-...	417	2072-..., 2076-1	242
1430-MU	134	1579-...	417	2074-..., 2078-1	242
1430-TXU	134	1580-...	420	2080-2100	239
1430-TTXU	134	1581-...	420	2130 - 2160	238
1430-TXEU	134	1582-...	412	2178-20	240
1430-TTXEU	134	1584-...	420	2179-...	237
1430-AU	134	1585-...	421	2179-S	237,239
1440-MU	136	1586-200	421	2184-...	248
1440-AU	136	1587-...	421	2185-...	238
1450-1D	128	1590/1590E	422	2400-...	247
1450-1UN	128	1591/1591E	422	2420-...	247
1450-1UN	128	1592	422	2601-...	249
1450-2V	128	1593/1593E	422	2602	249
1450-2ZI	128	1600-...	374	2850	487
1450-3	132	1601-1608	451	2855	487
1450-4	132	1609-1616	451	2860	487
1450-...	132	1612-1618	451	2865	487
1450-6	132	1613-1619	452	3000-IS...	226
1450-7	132	1620-...	372	3010-IN...	227
1450-8	133	1621-1636	452	3020-PH...	227
1450-13-15	133	1634-1639	453	3021-PZ...	227
770-870-1450	133	1640	456	3030-XZN...	228
1450-16	133	1640H	456	3040-RIB...	228
1455-M...	129	1641-...	456	3050-TX...	227
1455-IN...	130	1644-10	336	3050-IPR...	227
1455-IS...	130	1644-20	454	3070-TTX...	227
1455-PH...	130	1645-1652	453	3080-...	228

Code	Page	Code	Page
3090	229	4680	291
3090G	229	4690	291
3100-IS...	228	4700	291
3110-IN...	229	4710-...	290
3120-PH...	228	4720	290
3121-PZ...	228	4730	287
3130-XZN...	229	4740	290
3150-TX...	229	4760	286
3170-TTX...	229	4770	289
3200-IS...	157	5000	394
3210-IN...	158	5001	395
3210-INL...	158	5002	395
3210-KUL...	159	5003, 5004	394
3210-INA...	158	5005, 5006	397
3210-INZ	159	5007	402
3220-PH...	157	5008, 5009	401
3225-PZ...	157	5010, 5012	396
3230-XZN...	160	5011	396
3230-XZNL...	161	5014	397
3240-RIB...	161	5015	398
3243-TX...	131	5016	398
3243-TTX...	131	5017	399
3244-TX...	141	5018	400
3244-TTX...	141	5019	399
3244-TXL-45	141	5020	401
3245-TX...	159	5021	401
3245-TXL...	160	5022-...	402
3245-TTX...	160	5024-...	402
3300-...	230	5025-..., 5026-...	403
3400	232	5027-... / 5028-...	403
3401-S12	232	5110-ST, 5130-ST	300
3415	230	5120-ST	300
3426	203	5140-ST, 5150-ST, 5360-ST	302
3428	209	5160-ST, 5240-ST	300
3429	230	5160-STE, 5240-STE	295
3436-S36	232	5170-ST, 5180-ST, 5190-ST	300
3451-S7	231	5170-STE, 5180-STE, 5190-STE	295
3452ST	231	5200-ST	301
3453-S11	231	5210-ST	300
3500-IS...	140	5210-STE	295
3510-IN...	140	5220-ST, 5290-ST, 5300-ST	302
3510-INL...	141	5160-STE, 5240-STE	295
3510-INA...	140	5250	301
3520-PH...	140	5260-ST, 5270-ST, 5280-ST	301
3530-XZN...	142	5260-STE, 5270-STE, 5280-STE	295
3530-XZNL...	142	5310-ST, 5320-ST	302
4100-IS...	226	5330-ST, 5340-ST	301
4110-IN	226	5330-STE, 5340-STE	296
4120-PH...	226	5350-ST	301
4130-PZ...	226	5350-STE	296
4140-...	200	5370-ST	302
4150-...	230	7883-.../7884-...	200
4160-TX...	226	7893-.../7894-...	203
4481-...	497	7900-...	199
4490	343	7901-...	208
4510	286	7902-.../7905-.../7907-...	203
4510	286	7902-.../7912-...	208
4520-...	286	7902-.../7912-.../7922-...	214
4530-...	287	7903-.../7904-...	209
4540	287	7902-.../7912-...	214
4550-...	286	7906-...	202
4560	287	7907-...	199
4570	289	7911-...	213
4580-...	289	7912-7932	219
4590	289	7913-.../7914-...	214
4620	288	7921-...	218
4630	288	7923-.../7924-...	219
4640	288	7933-... / 7934-...	222
4660-...	291	7935-.../7936-...	225
4670	290	8421/8422/8423	420

A large area of the page is filled with horizontal dotted lines, providing a template for handwritten notes.

A series of horizontal dotted lines spanning the width of the page, intended for writing notes.

A large area of the page is filled with horizontal dotted lines, providing a template for handwritten notes.

A series of horizontal dotted lines spanning the width of the page, intended for writing notes.



ALWAYS READY

Our current general terms and conditions are available for you on our website www.ELORA.de.

The ELORA-Tool Catalogue E95

The Catalogue E95 cancels all previous catalogues, price lists and offers. All illustrations in the ELORA Catalogue E95 are unretouched and the tools are originating from current production or from stocks.

The measures given in the ELORA Catalogue E95 are not binding. Whilst every has been made to ensure accuracy of information given in the ELORA Catalogue E84 our policy of continuous improvement determines that we reserve the right to deviate from printed details and prices without prior notice to keep pace with latest developments.

Copyright: All texts, photos and illustrations are protected by copyright. No part of this material may be reproduced without our written permission.



THANK YOU

People all over the world place their trust in our products, being used daily and successfully for a variety of tasks. On behalf of the entire ELORA family, we wish to take this opportunity to express our sincere gratitude for this. Your loyalty is what drives us forward.

In future, we will continue to honour the trust in us with usual high quality and innovative ideas. As a German brand manufacturer, we take our responsibility seriously towards our customers, employees and partners and strive to meet respective demands as best as we can.



ELORA WERKZEUGFABRIK GMBH

Am Blaffertsberg 33, 42899 Remscheid
Tel.: +49 (0)2191.5627 - 0
Fax.: +49 (0)2191.5627 - 19
info@elora.de

www.elora.de

